

Mayor Edna B. DeVries
 Deputy Mayor Linda Combs
 Council Member Julie Berberich
 Council Member Richard W. Best
 Council Member Steve Carrington
 Council Member Sabrena Combs
 Council Member Jill Valerius

City Attorney Michael Gatti
 City Clerk Norma I. Alley, MMC
 City Manager John Moosey

City of Palmer, Alaska
City Council Meeting
August 11, 2020, at 7:00 PM
 City Council Chambers
 231 W. Evergreen Avenue, Palmer
www.palmerak.org

AGENDA

A. CALL TO ORDER

B. ROLL CALL

C. PLEDGE OF ALLEGIANCE

D. APPROVAL OF AGENDA

1. Approval of Consent Agenda
 - a. Introduction and Setting a Public Hearing to a Special Meeting on Wednesday, August 12, 2020, for **Ordinance No. 20-008:** Repealing Palmer Municipal Code Chapter 5.32 Marijuana Businesses, Prohibiting the Operation of Marijuana Cultivation Facilities, Marijuana Manufacturing Facilities, Marijuana Testing Facilities, and Retail Marijuana Stores Pursuant to AS 17.38.110 Local Control, but Not Restricting Industrial Hemp as Defined Herein.....Page 3
 - b. **Resolution No. 20-021:** Appointing Election Officials for the City of Palmer Regular Election on Tuesday, October 6, 2020..... Page 7
 - c. **Action Memorandum No. 20-055:** Authorizing the City Manager to Purchase One International Sand Truck Chassis in the Amount of \$102,657.12 Under the Governmental and Proprietary Procurements Section of Palmer Municipal Code 3.21.230 by Attaching the Purchase to the Sourcewell Vehicle and Chassis Contract#081716-NAVS Awarded to Navistar Inc. for New International Trucks..... Page 11
2. Approval of Minutes
 - a. July 14, 2020, Regular Meeting Page 27

E. REPORTS

1. City Manager’s Report
 - a. Cares Act Grant Program and Conflict of Interest..... Page 31
2. City Clerk’s Report
3. Mayor’s ReportPage 35
4. City Attorney’s Report

F. AUDIENCE PARTICIPATION

G. PUBLIC HEARING

1. **Resolution No. 20-019:** Issuance of Utility Revenue Bonds in the Principal Amount Not to Exceed \$8,000,000.00 to Finance Wastewater Utility Improvements, as Required by Federal Consent Decree, and to Submit the Question of the Issuance of such Bonds to the Qualified Voters of the City at the October 6, 2020 City Election (2nd Public Hearing) (Pending Motion) Page 37
2. **Resolution No. 20-005-A:** Amending the 2020 City of Palmer Budget for the Fiscal Year Ending December 31, 2020 Page 41

H. NEW BUSINESS

I. RECORD OF ITEMS PLACED ON THE TABLE

J. AUDIENCE PARTICIPATION

K. COUNCIL COMMENTS

L. ADJOURNMENT

Tentative Future Palmer City Council Meetings

Meeting Date	Meeting Type	Time	Notes
Aug 12	Special	6 pm	Special Public Hearing to consider repealing PMC 5.32 (Marijuana sales) favoring the referendum petition filed.
Aug 25	Regular	7 pm	
Sep 8	Regular	7 pm	
Sep 22	Regular	7 pm	
Oct 12	Special	6pm	Election Certification
Oct 13	Regular	7 pm	
Oct 27	Regular	7 pm	
Nov 10	Special	6 pm	Budget
Nov 10	Regular	7 pm	
Nov 24	Special	6 pm	Budget
Nov 24	Regular	7 pm	
Dec 8	Regular	7 pm	Budget
Dec 22	Regular	7 pm	
Jan 12 '21	Regular	7 pm	

**City of Palmer
Ordinance No. 20-008**

Subject: Repealing Palmer Municipal Code Chapter 5.32 Marijuana Businesses, Prohibiting the Operation of Marijuana Cultivation Facilities, Marijuana Manufacturing Facilities, Marijuana Testing Facilities, and Retail Marijuana Stores Pursuant to AS 17.38.110 Local Control, but Not Restricting Industrial Hemp as Defined Herein

Agenda of: August 11, 2020 – Introduction
August 12, 2020 – Public Hearing

Council Action: **Adopted** **Amended:** _____
 Defeated



Originator Information:

Originator: Council Member Valerius and Council Member S. Combs

Department Review:

Route to:	Department Director:	Signature:	Date:
_____	Community Development	_____	_____
_____	Finance	_____	_____
_____	Fire	_____	_____
_____	Police	_____	_____
_____	Public Works	_____	_____

Approved for Presentation By:

	Signature:	Remarks:
City Manager		_____
City Attorney		_____
City Clerk		_____

Certification of Funds:

Total amount of funds listed in this legislation: \$ _____

This legislation (√):

- Creates revenue in the amount of: \$ _____
- Creates expenditure in the amount of: \$ _____
- Creates a saving in the amount of: \$ _____
- Has no fiscal impact

Funds are (√):

- Budgeted Line item(s): _____
- Not budgeted _____

Director of Finance Signature: _____

Attachment(s):

- Ordinance No. 20-008

Summary Statement/Background:

As the Council has received a Referendum Ordinance on this topic that will be placed on the 2020 ballot, it is prudent of the City Council to be proactive on repealing PMC 5.32. When marijuana businesses were initially prohibited within City Limits, the marijuana industry was new to Alaska and there were many uncertainties. Years have passed and it is evident that this industry has adapted to normal, everyday life without causing disruption. It has also created large, additional tax income to the areas that allow marijuana business. In these uncertain times, it is imperative that the City of Palmer find additional revenue streams. Allowing marijuana businesses within City limits would be beneficial for economic growth, along with adding jobs to our community.

If passed, the City Council could work together with Planning & Zoning to create a plan moving forward – this could consist of limiting the zones in which these businesses could establish. Further discussion by the Council could formulate success for this industry and the City in the future.

LEGISLATIVE HISTORY

Introduced by: Council Members Valerius and S. Combs
Date: August 11, 2020
Public Hearing: August 12, 2020
Action:
Vote:

Yes:	No:

CITY OF PALMER, ALASKA
Ordinance No. 20-008

An Ordinance of the Palmer City Council Repealing Palmer Municipal Code Chapter 5.32 Marijuana Businesses, Prohibiting the Operation of Marijuana Cultivation Facilities, Marijuana Manufacturing Facilities, Marijuana Testing Facilities, and Retail Marijuana Stores Pursuant to AS 17.38.110 Local Control, but Not Restricting Industrial Hemp as Defined Herein

THE CITY OF PALMER, ALASKA, ORDAINS:

Section 1. Classification. This ordinance shall be permanent in nature and shall be incorporated into the Palmer Municipal Code.

Section 2. Severability. If any provisions of this ordinance or application thereof to any person or circumstances are held invalid, the remainder of this ordinance and the application to the other persons or circumstances shall not be affected thereby.

Section 3. Palmer Municipal Code is hereby amended to read as follows (new language is underlined and deleted language is stricken):

~~5.32.020 — Marijuana businesses prohibited:~~

~~A. Marijuana businesses are prohibited.~~

~~B. The prohibition contained in subsection (A) of this section shall not apply to or restrict any business, act, or commerce relating to the growing or processing of industrial hemp otherwise authorized by state or federal law, whether authorized by AS 17.38 or any other provision of state or federal law; nor shall the prohibition contained in subsection (A) of this section preclude issuance of a license or registration required for industrial hemp-related business or commerce to a qualified person or entity.~~

Section 4. Effective Date. Ordinance No. 20-008 shall take effect upon adoption by the city of Palmer City Council.

Passed and approved this ____ day of _____, 2020.

Edna B. DeVries, Mayor

Norma I. Alley, MMC, City Clerk

**City of Palmer
Resolution No. 20-021**

Subject: Appointing Election Officials for the City of Palmer Regular Election on Tuesday, October 6, 2020

Agenda of: August 11, 2020

Council Action: **Approved** **Amended:** _____
 Defeated

Originator Information:

Originator: Norma I. Alley, City Clerk

Department Review:

Route to:	Department Director:	Signature:	Date:
_____	Community Development	_____	_____
_____	Finance	_____	_____
_____	Fire	_____	_____
_____	Police	_____	_____
_____	Public Works	_____	_____

Approved for Presentation By:

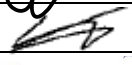
	Signature:	Remarks:
City Manager		_____
City Attorney		_____
City Clerk	<u>Norma I. Alley</u>	_____

Certification of Funds:

Total amount of funds listed in this legislation: \$ **\$2,680.00**

This legislation (√):

<input type="checkbox"/>	Creates revenue in the amount of:	\$ _____
<input checked="" type="checkbox"/>	Creates expenditure in the amount of:	\$ <u>2,680.00</u>
<input type="checkbox"/>	Creates a saving in the amount of:	\$ _____
<input type="checkbox"/>	Has no fiscal impact	

Funds are (√):

<input checked="" type="checkbox"/>	Budgeted	Line item(s): <u>01-02-10-6099 (\$2,160.00)</u>
<input checked="" type="checkbox"/>	Not budgeted	<u>01-02-10-6099 C19 (\$520.00)</u>

Director of Finance Signature: 

Attachment(s):

- Resolution No. 20-021

Summary Statement/Background:

Palmer Municipal Code 18.22.020(B) states, "the clerk shall recommend to the council at least three election officials for each precinct to constitute the election board for that precinct. The council shall, by resolution, appoint the election officials...".

Administration's Recommendation:

Approve Resolution No. 20-021

LEGISLATIVE HISTORY

Introduced by: Mayor by Request of City Clerk Alley
Date: August 11, 2020
Action:
Vote:

Yes:	No:

CITY OF PALMER, ALASKA

Resolution No. 20-021

A Resolution of the Palmer City Council Appointing Election Officials for the City of Palmer Regular Election on Tuesday, October 6, 2020

WHEREAS, in accordance with Section 18.22.020 of the Palmer Municipal Code, the following persons have been deemed qualified and have agreed to serve as Election Officials for the City of Palmer Regular Election on Tuesday, October 6, 2020:

Poll Election Officials:

Precinct 11-070 Mat-Su Borough Building	Precinct 11-075 Palmer Senior Center
Meredith "Jo" Weller (Chair)	Cynthia Medbery (Chair)
Virginia Sweeney	Sandra Woolsey
Cheryl Katje	Kama Petty
Hillary Palmer	Barbara Entsminger
Charles Geary	Debra Tuomi
Elizabeth Stevens-Orczewska	Verona Doyal

NOW, THEREFORE BE IT RESOLVED that the Palmer City Council confirms the appointment of these individuals as Election Officials for the October 6, 2020, City of Palmer Regular Election.

Approved by the Palmer City Council this ____ day of _____, 2020.

Edna B. DeVries, Mayor

Norma I. Alley, MMC, City Clerk

**City of Palmer
Action Memorandum No. 20-055**

Subject: Authorizing the City Manager to Purchase One International Sand Truck Chassis in the Amount of \$102,657.12 Under the Governmental and Proprietary Procurements Section of Palmer Municipal Code 3.21.230 by Attaching the Purchase to the Sourcewell Vehicle and Chassis Contract#081716-NAVS Awarded to Navistar Inc. for New International Trucks

Agenda of: August 11, 2020

Council Action: **Approved** **Amended:** _____
 Defeated

Originator Information:

Originator: Chris Nall, Director of Public Works

Department Review:

Route to:	Department Director:	Signature:	Date:
_____	Community Development	_____	_____
<u> </u> √	Finance	<u><i>[Signature]</i></u>	<u>7/23/2020</u>
_____	Fire	_____	_____
_____	Police	_____	_____
<u> </u> √	Public Works	<u><i>[Signature]</i></u>	<u>7/17/2020</u>

Approved for Presentation By:

	Signature:	Remarks:
City Manager	<u><i>[Signature]</i></u>	_____
City Attorney	<u><i>[Signature]</i></u>	_____
City Clerk	<u><i>[Signature]</i></u>	_____

Certification of Funds:

Total amount of funds listed in this legislation: \$ **102,657.12**

This legislation (√):

- Creates revenue in the amount of: \$ _____
- Creates expenditure in the amount of: \$ **102,657.12**
- Creates a saving in the amount of: \$ _____
- Has no fiscal impact

Funds are (√):

- Budgeted Line item(s): 09-01-10-6054 Public Works Equipment
- Not budgeted

Director of Finance Signature: *[Signature]*

Attachment(s):

- International Chassis Component Configuration
- CoP Sourcewell Proposal

Summary Statement/Background:

This action memorandum requests authorization to purchase one new Chassis from RWC International, LTD to replace the current sander truck chassis which rusted through.

By purchasing the vehicle through the Sourcewell contract, the City is able to take advantage of the following savings:

- The City does not bear the expense and resources of preparing and carrying out the typical bid process
- The City, by attaching itself to Sourcewell who purchases many heavy-duty vehicles per year, enjoys a greater discount versus buying heavy vehicles every 10 years; and
- The City benefits from the fact that the Sourcewell procurement is locked into fuel, freight, and production rates based on last fall's pricing that is considerably lower than the rapidly escalating fuel and steel surcharges that have increased shipping and production costs.

3.21.230 Governmental and proprietary procurements.

A. The purchasing officer may contract, without the use of the competitive source selection procedures of this chapter, for the following supplies, services, professional services or construction:

1. For contracts, including reimbursable agreements, with federal, state or local units of government or utility provider where the city has a financial responsibility or beneficial interest in entering into an agreement.
2. For contracts issued pursuant to any federal, state, or local government contract where the city is an authorized user, or where the resulting contractor agrees to extend the same terms, conditions, and pricing to the city as those awarded under the original contract, all in accordance with PMC 3.21.240. Such agreements shall be limited to those contracts where the award is issued pursuant to a formally advertised solicitation.
3. For contracts where the purchasing officer determines in writing that the city's requirements reasonably limit the source for the supplies, services, professional service or construction to one person.

B. All contract awards under this section, and any amendments there to, shall be subject to the applicable approval requirements of PMC 3.21.090 prior to execution.

C. No contractor may provide supplies, services, professional services, or construction to the city before the applicable requirements of this section are first satisfied.

Administration's Recommendation:

To approve Action Memorandum No. 20-055

Model/Feature Information		
Model:	HV60700/HV50700	HV607 SBA/HV507 SFA
Cab:	16030	DAY CAB
Aftertreatment:	07BLG	HORZ-VERT UC, RAISED
Fuel Tank:	15SGG/15SMD	70 GAL 19" DEEP D
Battery Box:	08VUL/08VUM	18" STEEL/ALUMINUM
Air Tanks:	04VCL	11" PARALLEL, RAISED
DEF Tank:	15WDG	7 GAL
Engine:		L9

General Configuration Information
TRUCK CONFIGURATION HIGH GROUND CLEARANCE CONFIG
AIR DRYER INSIDE LT (04VKC)
FUEL FILTER OUTSIDE LT 41" BOC (15LLZ)

Minimum Wheelbase
6x4 54" HMX ≥ 179" – SBA ≥ 187" – SFA
4x2 VARI-RATE ≥ 150" – SBA ≥ 158" – SFA

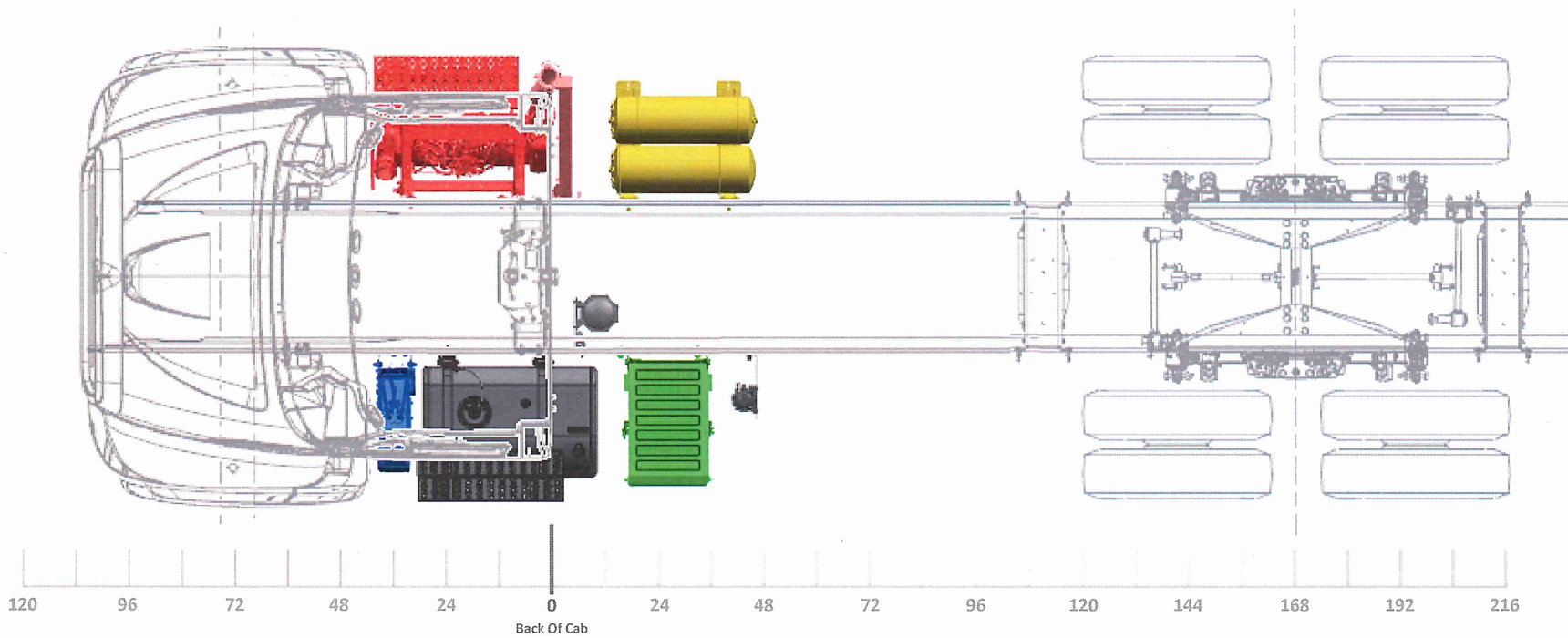



HV607 SBA

Sales Proposal For:

CITY OF PALMER

Presented By:

RWC INTERNATIONAL, LTD.

Prepared For:
CITY OF PALMER
Greg Wickham
231 Evergreen Ave.
Palmer, AK 99645-
(907)745 - 3271
Reference ID: 2021 SANDER

Presented By:
RWC INTERNATIONAL, LTD.
Greg Martin
7880 SANDLEWOOD PLACE
ANCHORAGE AK 99507 -
(907)279-9591

Thank you for the opportunity to provide you with the following quotation on a new International truck. I am sure the following detailed specification will meet your operational requirements, and I look forward to serving your business needs.

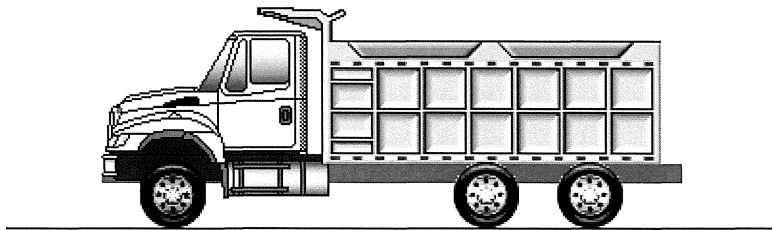

Model Profile
2021 HV607 SBA (HV607)

AXLE CONFIG:	6X4
APPLICATION:	Front Plow and Underbelly Scraper with Spreader
MISSION:	Requested GVWR: 56000. Calc. GVWR: 56000 Calc. Start / Grade Ability: 22.16% / 2.01% @ 55 MPH Calc. Geared Speed: 70.3 MPH
DIMENSION:	Wheelbase: 187.00, CA: 119.90, Axle to Frame: 75.00
ENGINE, DIESEL:	{Cummins L9 350} EPA 2017, 350HP @ 2000 RPM, 1000 lb-ft Torque @ 1400 RPM, 2200 RPM Governed Speed, 350 Peak HP (Max)
TRANSMISSION, AUTOMATIC:	{Allison 3000 RDS} 5th Generation Controls, Close Ratio, 6-Speed with Double Overdrive, with PTO Provision, Less Retarder, Includes Oil Level Sensor, with 80,000-lb GVW and GCW Max, On/Off Highway
CLUTCH:	Omit Item (Clutch & Control)
AXLE, FRONT NON-DRIVING:	{Meritor MFS-16-143A} Wide Track, I-Beam Type, 16,000-lb Capacity
AXLE, REAR, TANDEM:	{Meritor MT-40-14X-4DCR} Single Reduction, 40,000-lb Capacity, w/.433"(11mm) Wall Housing Thickness, Driver Controlled Locking Differential in Forward-Rear and Rear-Rear Axle, R Wheel Ends Gear Ratio: 5.86
CAB:	Conventional, Day Cab
TIRE, FRONT:	(2) 315/80R22.5 Load Range L HSC 3 (CONTINENTAL), 481 rev/mile, 68 MPH, All-Position
TIRE, REAR:	(8) 11R22.5 Load Range G HYBRID HD3 (CONTINENTAL), 493 rev/mile, 75 MPH, Drive
SUSPENSION, REAR, TANDEM:	{Hendrickson HMX-400-54} Walking Beam, 40,000-lb Capacity, 54" Axle Spacing, Rubber Springs, with Transverse Torque Rods, Rubber End Bushings
PAINT:	Cab schematic 100WL Location 1: 9219, Winter White (Std) Chassis schematic N/A

(0012EHX)

ATTACHMENTS: 0012VXT 0012THT 0007SDP

<u>Parameter</u>	<u>Value</u>	<u>UOM</u>
Max Accelerator Vehicle Speed	68	MPH
Road Speed Governor Upper Droop	0	MPH
Road Speed Governor Lower Droop	0	MPH
Vehicle Speed Limiter Override	N, DISABLE FEATURE OR FUNCTION	N/A
VSLO Maximum Road Speed Delta	0	MPH
VSLO Maximum Distance	47	MILES
Max Engine Speed No Veh Speed Sensr	2097	RPM
LBSC Enable	N, DISABLE FEATURE OR FUNCTION	N/A
LBSC - Engine Speed Breakpoint	1800	RPM
Gear Down Protection Enable	N, DISABLE FEATURE OR FUNCTION	N/A
GDP - Heavy Load Vehicle Speed	62	MPH
GDP - Light Load Vehicle Speed	57	MPH
Driver Reward Enable	N, DISABLE FEATURE OR FUNCTION	N/A
Driver Reward Mode	0, ROAD SPEED GOVERNOR	N/A
Fuel Economy - Expected Level	5.88	MPG
Fuel Economy - Good Level	6.47	MPG
Fuel Economy - Best Level	6.92	MPG
% Idle Time - Expected Level	30	%
% Idle Time - Good Level	20	%
% Idle Time - Best Level	10	%
Speed Reward - Expected Level	0	MPH
Speed Reward - Good Level	0	MPH
Speed Reward - Best Level	0	MPH
Speed Reward - Penalty Level	0	MPH
Idle Speed Adjustment Enable	Y, ENABLE FEATURE OR FUNCTION	N/A
Low Idle Speed	750	RPM
Idle Shutdown Enable	N, DISABLE FEATURE OR FUNCTION	N/A
ISD Time Before Shutdown	15.0	MIN
ISD Percent Engine Loading	100	%
ISD With PTO	N, DISABLE FEATURE OR FUNCTION	N/A
ISD Manual Override	N, DISABLE FEATURE OR FUNCTION	N/A
ISD With Parking Brake Set	N, DISABLE FEATURE OR FUNCTION	N/A
ISD Ambient Temperature Override	N, DISABLE FEATURE OR FUNCTION	N/A
ISD Cold Ambient Air Temperature	30	F
ISD Intermediate Ambient Air Temp	40	F
ISD Hot Ambient Air Temperature	81	F
ISD Manual Override Inhibit Zone En	N, DISABLE FEATURE OR FUNCTION	N/A
ISD Hot Ambient Automatic Override	Y	N/A
ISD Engine Coolant Temp Threshold	30	F
Vehicle Acceleration Management	N, DISABLE FEATURE OR FUNCTION	N/A
Variable Acceleration Speed 1	20	MPH
Variable Acceleration Speed 2	50	MPH
Variable Acceleration Rate 1	3.60	MPH/SEC
Variable Acceleration Rate 2	3.60	MPH/SEC
Cruise Control Enable	Y, ENABLE FEATURE OR FUNCTION	N/A
CC Maximum Vehicle Speed	68	MPH
CC Save Set Speed	N, DISABLE FEATURE OR FUNCTION	N/A
CC Upper Droop	0.0	MPH
CC Lower Droop	0.0	MPH
CC Auto Resume	N, DISABLE FEATURE OR FUNCTION	N/A
Engine Fan Min On Time For AC	30	SEC
Remote Accelerator Enable	N, DISABLE FEATURE OR FUNCTION	N/A
Remote Accelerator Mode	1, REMOTE ACCELERATOR PEDAL OR LEVER WITH TRANS VERIFICATION	N/A
PTO Enable	Y, ENABLE FEATURE OR FUNCTION	N/A

PTO In Cab Mode	Y, ENABLE FEATURE OR FUNCTION	N/A
Remote PTO Enable	N, DISABLE FEATURE OR FUNCTION	N/A
Remote Station PTO Enable	N, DISABLE FEATURE OR FUNCTION	N/A
PTO Max Engine Speed	2200	RPM
PTO Min Engine Speed	750	RPM
PTO Maximum Engine Load	800	LB-FT
PTO Max Vehicle Speed	2	MPH
PTO Accelerator Override	N, DISABLE FEATURE OR FUNCTION	N/A
PTO Accel Override Max Engine Speed	2400	RPM
PTO Clutch Override	N, DISABLE FEATURE OR FUNCTION	N/A
PTO Service Brake Override	Y, ENABLE FEATURE OR FUNCTION	N/A
PTO Parking Brake Interlock Mode	1, PTO PRK BRK INT TYPE SET TO CAB ONLY	N/A
PTO Transmission Neutral Interlock	Y, ENABLE FEATURE OR FUNCTION	N/A
PTO Eng Spd Limit w/VSS Limit	N, DISABLE FEATURE OR FUNCTION	N/A
PTO Ignore Vehicle Speed Sensor	N, DISABLE FEATURE OR FUNCTION	N/A
PTO Resume Switch Speed	925	RPM
PTO Set Switch Speed	850	RPM
PTO Additional Switch Speed	1500	RPM
PTO Ramp Rate	250	RPM/SEC
Remote PTO Number of Speed Settings	1	N/A
Remote PTO Speed Setting 1	1000	RPM
Remote PTO Speed Setting 2	1200	RPM
Remote PTO Speed Setting 3	1400	RPM
Remote PTO Speed Setting 4	1400	RPM
Remote PTO Speed Setting 5	1500	RPM
Remote Station PTO Resume Sw Spd	1000	RPM
Remote Station PTO Set Switch Speed	1500	RPM
Remote Station PTO Addition Sw Spd	1500	RPM
Transmission Driven PTO	N, DISABLE FEATURE OR FUNCTION	N/A
Transmission Driven PTO Type	0, ENGINE DRIVEN STEADY LOAD	N/A
Powertrain Protection Enable	N, DISABLE FEATURE OR FUNCTION	N/A
Max Torque Allow By Axle/Driveshaft	23602	LB-FT
Max Torque in Top Gear Range	2995	LB-FT
Max Torque in Int. Gear Range	2995	LB-FT
Max Torque in Low Gear Range	2995	LB-FT
Max Torque w/o Vehicle Speed	1475	LB-FT
Lowest Gear of Top Gear Range	2.00	N/A
Lowest Gear of Int. Gear Range	3.00	N/A
Lowest Gear of Low Gear Range	6.00	N/A
Engine Protection Shutdown	N, DISABLE FEATURE OR FUNCTION	N/A
Engine Protection Restart Inhibit	N, DISABLE FEATURE OR FUNCTION	N/A
Engine Prot Coolant Level Shutdown	N, DISABLE FEATURE OR FUNCTION	N/A
Sudden Veh Speed Decel Threshold	6.96	MPH
Trip Information Vehicle Ovrsped1	0	MPH
Trip Information Vehicle Ovrsped2	0	MPH
Veh Speed Sensor Anti Tamper Level	1, HIGH LEVEL	N/A
Maintenance Monitor Enable	N	N/A
Maintenance Monitor Operating Mode	0, MAINTENANCE MONITOR AUTOMATIC MODE OF OPERATION	N/A
Maintenance Monitor Alert Percent	90	%
Maintenance Monitor Distance	15000	MILES
Maintenance Monitor Fuel	2000	GALLONS
Maintenance Monitor Time	500	HOURS
Maintenance Monitor Interval Factor	1.00	N/A
Master Password	000000	N/A
Adjustment Password	000000	N/A
Reset Password	000000	N/A

These Electronic Parameters have been successfully finalized

<u>Code</u>	<u>Description</u>	<u>List</u> (US DOLLAR)
HV60700	Base Chassis, Model HV607 SBA with 187.00 Wheelbase, 119.90 CA, and 75.00 Axle to Frame.	\$92,154.00
1570	TOW HOOK, FRONT (2) Frame Mounted	\$84.00
1AND	AXLE CONFIGURATION {Navistar} 6x4	\$1,524.00
1CAJ	FRAME RAILS Heat Treated Alloy Steel (120,000 PSI Yield); 10.866" x 3.622" x 0.437" (276.0mm x 92.0mm x 11.1mm); 456.0" (11582mm) Maximum OAL	\$783.00
1LLA	BUMPER, FRONT Swept Back, Steel, Heavy Duty	\$0.00
1WDS	FRAME EXTENSION, FRONT Integral; 20" In Front of Grille	\$590.00
1WGX	WHEELBASE RANGE 169" (430cm) Through and Including 219" (555cm)	\$611.00
1WRN	BRACKET, CAB MOUNT Heavy Duty	\$57.00
2ARU	AXLE, FRONT NON-DRIVING {Meritor MFS-16-143A} Wide Track, I-Beam Type, 16,000-lb Capacity	\$2,100.00
3ADE	SUSPENSION, FRONT, SPRING Parabolic Taper Leaf, Shackle Type, 16,000-lb Capacity, with Shock Absorbers	\$350.00
4091	BRAKE SYSTEM, AIR Dual System for Straight Truck Applications	\$0.00
4193	BRAKES, FRONT, AIR CAM 16.5" x 6", Includes 24 SqIn Long Stroke Brake Chambers	(\$1,368.00)
4732	DRAIN VALVE {Berg} with Pull Chain, for Air Tank	\$0.00
4AZA	AIR BRAKE ABS {Bendix AntiLock Brake System} Full Vehicle Wheel Control System (4-Channel)	\$0.00
4EBS	AIR DRYER {Bendix AD-9} with Heater	\$450.00
4EXV	BRAKE CHAMBERS, FRONT AXLE {Bendix} 24 SqIn	\$0.00
4EXW	BRAKE CHAMBERS, REAR AXLE {Bendix EnduraSure Pro} 30/30 Spring Brake	\$162.00
4NDB	BRAKES, REAR, AIR CAM S-Cam; 16.5" x 7.0"; Includes 30/30 Sq.In. Long Stroke Brake Chamber and Spring Actuated Parking Brake	(\$3,048.00)
4SPA	AIR COMPRESSOR {Cummins} 18.7 CFM	\$0.00
4VCL	AIR TANK LOCATION (2) Mounted 25" Back of Cab, Outside Right Rail, with Ground Clearance	\$208.00
4VKC	AIR DRYER LOCATION Mounted Inside Left Rail, Back of Cab	\$50.00
5708	STEERING COLUMN Tilting	\$125.00
5CAW	STEERING WHEEL 4-Spoke; 18" Dia., Black	\$0.00
5PSL	STEERING GEAR {Sheppard M110} Power	\$457.00
6DGT	DRIVELINE SYSTEM {Dana Spicer} SPL170 Main Driveline with SPL170 Interaxle Shaft, for 6x4	\$612.00
7BEU	AFTERTREATMENT COVER Aluminum	\$278.00
7BLG	EXHAUST SYSTEM Single, Horizontal Aftertreatment Device, Frame Mounted Right Side Under Cab, Includes Single Vertical Tail Pipe, Frame Mounted Right Side Back of Cab, for Improved Ground Clearance	\$2,178.00
7SDP	ENGINE COMPRESSION BRAKE {Jacobs} for Cummins ISL/L9 Engines; with Selector Switch and On/Off Switch	\$2,132.00

<u>Code</u>	<u>Description</u>	<u>List</u> (US DOLLAR)
7WBA	TAIL PIPE (1) Turnback Type, Bright	\$208.00
7WCR	EXHAUST HEIGHT 10' 11"	\$72.00
7WDN	MUFFLER/TAIL PIPE GUARD (1) Aluminum	\$0.00
8000	ELECTRICAL SYSTEM 12-Volt, Standard Equipment	\$0.00
8518	CIGAR LIGHTER Includes Ash Cup	\$18.00
8GXD	ALTERNATOR {Leece-Neville AVI160P2013} Brush Type; 12 Volt 160 Amp. Capacity, Pad Mount, with Remote Sense	\$0.00
8HAB	BODY BUILDER WIRING Back of Day Cab at Left Frame or Under Sleeper, Extended or Crew Cab at Left Frame; Includes Sealed Connectors for Tail/Amber Turn/Marker/ Backup/ Accessory Power/Ground and Sealed Connector for Stop/Turn	\$100.00
8MSG	BATTERY SYSTEM {Fleetrite} Maintenance-Free, (3) 12-Volt 1980CCA Total, Top Threaded Stud	\$103.00
8RMH	BATTERY DISCONNECT SWITCH {Cole-Hersee 75920-06} 300 Amp, Disconnects Charging Circuits, Locks with Padlock, Battery Box Mounted	\$176.00
8RML	RADIO AM/FM/WB/Clock/Bluetooth/USB Input/Auxiliary Input, MP3, Apple Device Play & Control	\$483.00
8RMZ	SPEAKERS (2) 6.5" Dual Cone Mounted in Both Doors, (2) 5.25" Dual Cone Mounted in Both B-Pillars	\$138.00
8THB	BACK-UP ALARM Electric, 102 dBA	\$120.00
8VAY	HORN, ELECTRIC Disc Style	\$0.00
8VUL	BATTERY BOX Steel, with Plastic Cover, 18" Wide, 2-4 Battery Capacity, Mounted Left Side Back of Cab	\$177.00
8WBW	JUMP START STUD Remote Mounted	\$168.00
8WNH	RUNNING LIGHT (2) Daytime	\$58.00
8WPH	CLEARANCE/MARKER LIGHTS (5) {Truck Lite} Amber LED Lights, Flush Mounted on Cab or Sunshade	\$0.00
8WPZ	TEST EXTERIOR LIGHTS Pre-Trip Inspection will Cycle all Exterior Lamps Except Back-up Lights	\$42.00
8WTK	STARTING MOTOR {Delco Remy 38MT Type 300} 12 Volt, Less Thermal Over-Crank Protection	\$193.00
8WWJ	INDICATOR, LOW COOLANT LEVEL with Audible Alarm	\$0.00
8XAH	CIRCUIT BREAKERS Manual-Reset (Main Panel) SAE Type III with Trip Indicators, Replaces All Fuses	\$0.00
8XGT	TURN SIGNALS, FRONT Includes LED Side Turn Lights Mounted on Fender	\$0.00
8XHN	HORN, AIR Black, Single Trumpet, with Lanyard Pull Cord	\$94.00
8XHR	POWER SOURCE, ADDITIONAL Auxiliary Power Outlet (APO) & USB Port, Located in the Instrument Panel	\$38.00
9585	FENDER EXTENSIONS Rubber	\$104.00
9AAB	LOGOS EXTERIOR Model Badges	\$0.00
9AAE	LOGOS EXTERIOR, ENGINE Badges	\$0.00

<u>Code</u>	<u>Description</u>	<u>List</u> (US DOLLAR)
9HBM	GRILLE Stationary, Chrome	\$0.00
9WAC	BUG SCREEN Mounted Behind Grille	\$131.00
9WBC	FRONT END Tilting, Fiberglass, with Three Piece Construction, for WorkStar/HV	\$0.00
10060	PAINT SCHEMATIC, PT-1 Single Color, Design 100	\$0.00
10761	PAINT TYPE Base Coat/Clear Coat, 1-2 Tone	\$0.00
10BAE	LABEL, DEF "DEF ONLY"	\$8.00
10JPA	CUSTOMER IDENTITY for National Joint Powers Alliance	\$0.00
10SLV	PROMOTIONAL PACKAGE Government Silver Package	\$0.00
10WCY	SAFETY TRIANGLES	\$47.00
10XAN	FIRE EXTINGUISHER 5 lb Class A B C	\$154.00
10XAP	FIRE EXTINGUISHER BRACKET Mounted Left Side Driver Seat	\$0.00
11001	CLUTCH Omit Item (Clutch & Control)	\$0.00
12703	ANTI-FREEZE Red, Extended Life Coolant; To -40 Degrees F/ -40 Degrees C, Freeze Protection	\$0.00
12851	PTO EFFECTS, ENGINE FRONT Less PTO Unit, Includes Adapter Plate on Engine Front Mounted	\$353.00
12EHX	ENGINE, DIESEL {Cummins L9 350} EPA 2017, 350HP @ 2000 RPM, 1000 lb-ft Torque @ 1400 RPM, 2200 RPM Governed Speed, 350 Peak HP (Max)	\$9,757.00
12THT	FAN DRIVE {Horton Drivemaster} Direct Drive Type, Two Speed with Residual Torque Device for Disengaged Fan Speed	\$0.00
12UWZ	RADIATOR Cross Flow, Series System; 1228 SqIn Aluminum Radiator Core with Internal Water to Oil Transmission Cooler and 1167 In Charge Air Cooler	\$0.00
12VBB	AIR CLEANER Dual Element	\$108.00
12VHJ	FEDERAL EMISSIONS {Cummins L9} EPA, OBD and GHG Certified for Calendar Year 2020	\$0.00
12VXT	THROTTLE, HAND CONTROL Engine Speed Control; Electronic, Stationary, Variable Speed; Mounted on Steering Wheel	\$0.00
12WCG	HOSE CLAMPS, RADIATOR HOSES {R.G. Ray Mini Flex Seal} Coil Spring/"T"-Bolt Type, for Radiator Hoses over 1" I.D.	\$54.00
12WUL	BLOCK HEATER, ENGINE {Phillips} 120V/1000W, with "Y" Cord for Dealer Installed 120V/300W Oil Pan Heater	\$116.00
12WZE	EMISSION COMPLIANCE Federal, Does Not Comply with California Clean Air Idle Regulations	\$0.00
12XAT	ENGINE CONTROL, REMOTE MOUNTED Provision for; Includes Wiring for Body Builder Installation of PTO Controls; with Ignition Switch Control for Cummins ISB/B6.7 or ISL/L9 Engines	\$45.00
13AVR	TRANSMISSION, AUTOMATIC {Allison 3000 RDS} 5th Generation Controls, Close Ratio, 6-Speed with Double Overdrive, with PTO Provision, Less Retarder, Includes Oil Level Sensor, with 80,000-lb GVW and GCW Max, On/Off Highway	\$10,133.00
13WET	TRANSMISSION SHIFT CONTROL for Column Mounted Stalk Shifter	\$50.00
13WLP	TRANSMISSION OIL Synthetic; 29 thru 42 Pints	\$203.00

<u>Code</u>	<u>Description</u>	<u>List</u> (US DOLLAR)
13WUC	ALLISON SPARE INPUT/OUTPUT for Rugged Duty Series (RDS); General Purpose Trucks, Construction	\$0.00
13WWW	NEUTRAL AT STOP OMIT	\$0.00
13WYU	SHIFT CONTROL PARAMETERS Allison 3000 or 4000 Series Transmissions, 5th Generation Controls, Performance Programming	\$0.00
13XAL	PTO LOCATION Customer Intends to Install PTO at Left Side of Transmission	\$0.00
14GVN	AXLE, REAR, TANDEM {Meritor MT-40-14X-4DCR} Single Reduction, 40,000-lb Capacity, w/.433"(11mm) Wall Housing Thickness, Driver Controlled Locking Differential in Forward-Rear and Rear-Rear Axle, R Wheel Ends . Gear Ratio: 5.86	\$10,038.00
14ULX	SUSPENSION, REAR, TANDEM {Hendrickson HMX-400-54} Walking Beam, 40,000-lb Capacity, 54" Axle Spacing, Rubber Springs, with Transverse Torque Rods, Rubber End Bushings	\$4,249.00
14WAL	SUSPENSION/REAR-AXLE IDENTITY for Meritor Tandem Rear Axles with Bar-Pin Beam Attachment Type Suspensions	\$0.00
14WBV	SHOCK ABSORBERS, REAR (4) for Hendrickson HMX Suspension Only, Mounted from Frame to Beam	\$878.00
15LLZ	LOCATION FUEL/WATER SEPARATOR Mounted Outside Left Rail, 41" Back of Cab	\$50.00
15LMN	FUEL/WATER SEPARATOR {Racor 400 Series,} 12 VDC Electric Heater, Includes Pre-Heater, with Primer Pump, Includes Water-in-Fuel Sensor	\$123.00
15SGG	FUEL TANK Top Draw, Non-Polished Aluminum, D-Style, 19" Tank Depth, 70 US Gal (265L), Mounted Left Side, Under Cab	\$253.00
15WDG	DEF TANK 7 US Gal (26L) Capacity, Frame Mounted Outside Left Rail, Under Cab	\$0.00
16030	CAB Conventional, Day Cab	\$0.00
16BAL	HEATER	\$0.00
16GDC	GAUGE CLUSTER Base Level; English with English Speedometer and Tachometer, for Air Brake Chassis, Includes Engine Coolant Temperature, Primary and Secondary Air Pressure, Fuel and DEF Gauges, Oil Pressure Gauge, Includes 3 Inch Monochromatic Text Display	\$0.00
16HHE	GAUGE, AIR CLEANER RESTRICTION {Filter-Minder} with Black Bezel, Mounted in Instrument Panel	\$30.00
16HKT	IP CLUSTER DISPLAY On Board Diagnostics Display of Fault Codes in Gauge Cluster	\$0.00
16LER	SEAT, PASSENGER {National} Air-Suspension, High Back with Integral Headrest, Mordura Cloth, Isolated, 1 Chamber Lumbar, 2 Position Front Cushion Adjust, -3 to +14 Degree Back Angle Adjustment	\$731.00
16LSD	SEAT, DRIVER {National 2000} Air Suspension, High Back with Integral Headrest, Mordura Cloth, Isolated, with 2 Position Front Cushion Adjustment, -3 to +14 Degree Seat Back Adjustment, Single Chamber Air Lumbar Support	\$263.00
16SEE	GRAB HANDLE, EXTERIOR Chrome, Towel Bar Type, with Anti-Slip Rubber Inserts, for Cab Entry Mounted Left Side at B-Pillar	\$118.00
16SNV	MIRRORS (2) Aero Pedestal, Power Adjust, Heated, Turn Signals, Bright Heads, Black Arms, 6.5" x 14" Flat Glass, Includes 6.5" x 6" Convex Mirrors, for 102" Load Width	\$540.00
16VKB	CAB INTERIOR TRIM Classic, for Day Cab	\$0.00
16WBY	ARM REST, RIGHT, DRIVER SEAT	\$39.00

<u>Code</u>	<u>Description</u>	<u>List</u> (US DOLLAR)
16WEE	CAB SOUND INSULATION Includes Dash Insulator and Engine Cover Insulator	\$90.00
16WHJ	HOSE CLAMPS, HEATER HOSE {Breeze} Belleville Washer Type	\$25.00
16WJU	WINDOW, POWER (2) and Power Door Locks, Left and Right Doors, Includes Express Down Feature	\$367.00
16WSK	CAB REAR SUSPENSION Air Bag Type	\$0.00
16XJN	INSTRUMENT PANEL Flat Panel	\$0.00
16XWD	SUNSHADE, EXTERIOR Aerodynamic, Painted Roof Color, with Integral Clearance/Marker Lights	\$253.00
16ZBT	ACCESS, CAB Steel, Driver & Passenger Sides, Two Steps per Door, for use with Day Cab and Extended Cab	\$0.00
27DUL	WHEELS, FRONT {Accuride 29300} DISC; 22.5x9.00 Rims, Powder Coat Steel, 5-Hand Hole, 10-Stud, 285.75mm BC, Hub-Piloted, Flanged Nut, with Steel Hubs	\$204.00
28DUK	WHEELS, REAR {Accuride 29169} DUAL DISC; 22.5x8.25 Rims, Powder Coat Steel, 5-Hand Hole, 10-Stud, 285.75mm BC, Hub-Piloted, Flanged Nut, with .472" Thick Increased Capacity Disc and Steel Hubs	\$254.00
60AKG	BDY INTG, PTO ACCOMMODATION for (3) Latched Rocker Switches, (1) PTO Switch, (2) Generic Switches to Control (3) 30 amp relays, with Programmable Interlocks, for Body Builder Hook up in the Engine Compartment Left Side, Recommended for Automatic Transmissions	\$148.00
7372135428	(8) TIRE, REAR 11R22.5 Load Range G HYBRID HD3 (CONTINENTAL), 493 rev/mile, 75 MPH, Drive	\$32.00
7792545438	(2) TIRE, FRONT 315/80R22.5 Load Range L HSC 3 (CONTINENTAL), 481 rev/mile, 68 MPH, All-Position	\$704.00
	Total of Product Features	\$143,329.00
	Services Section:	
40128	WARRANTY Standard for HV507, HV50B, HV607 Models, Effective with Vehicles Built July 1, 2017 or Later, CTS-2025A	\$0.00
40LUY	SRV CONTRACT, EXT MAJOR COMP {Navistar Prepackaged Components} To 60-Month/100,000 Miles (160,000 km), Includes Front Axle, Rear Axle, Propshaft, and Transfer Case	\$620.00
40SZD	SRV CONTRACT, EXT CMS ENG/AFTR {Cummins} To 60-Month/100,000 Miles (160,000 km), Extended Cummins L9 Engine Coverage, Protection Plan 1 and Aftertreatment	\$4,380.00
40TVU	SRV CONTRACT, EXT ALLISON XMSN {Allison} To 60-Month/Unlimited Miles/km, for Allison 3000 RDS with Utility or Other Vocations (ST08, ST17-ST22, TT01, TT02, TT05, AG04, SP01, SP03-SP05)	\$1,264.00
	Total of Service Features	\$6,264.00
	Total List Price Including Options:	\$149,593.00
TSC	OIL PAN HEATER, 300W Immersion Type	\$238.35
	FET Tires	(\$325.10)
	Flooring Interest, Additional, 30, For Delivery and Net 30 Days Payment Terms	\$411.00

Code

Description

List

(US DOLLAR)

Total Goods Purchased:

\$324.25



RWC International, Ltd is pleased to provide you with this proposal compliant with all terms of the Sourcewell Vehicles and Chassis Contract #081716-NVS awarded to Navistar, Inc for new International Truck, effective 3/13/19. If you have any questions regarding enrollment in Sourcewell or detailed contract terms and conditions, please see your International Truck sales representative.

PROPOSAL PREPARED FOR:		PROPOSAL PREPARED BY:	
Sourcewell Member:	City of Palmer	RWC Internaional Ltd	
Contact:	Greg Wickham	Greg Martin	
Address:	231 W. Evergreen Ave.	7880 Sandlewood Place	
City/State/Zip:	Palmer, AK 99645	Anchorage, Alaska 99507	
Phone:	(907) 745-3400	(907) 265-0223	
Email:	gwickham@palmerak.org	gmartin@rwcgroup.com	

Proposal Number	5120-05
Date	1/8/2020
Quantity of this Specification	1
Single Sourcewell Transaction Total Volume	1

Chassis		
New 2021 International HV607 6X4 Chassis		\$ 143,329.00
Base Chassis List	\$ 92,154.00	
Options List	\$ 51,175.00	
Sourcewell Contract Discount	33.2%	\$ (47,585.23)
Volume Incentive		\$ -
Net Sourcewell Chassis Price		\$ 95,743.77
Sourcewell Partner Body		
		\$ -
		\$ -
		\$ -
		\$ -
Non-Sourcewell Dealer Supplied Body		
		\$ -
		\$ -
		\$ -
		\$ -
Handling Fee	5.00%	\$ -
Additional Post Build Work		
Oil Pan Heater, 300W Immersion Type		\$ 227.00
		\$ -
		\$ -
		\$ -
		\$ -
		\$ -
Handling Fee	5.00%	\$ 11.35
Service Contracts		
SRV CONTRACT, EXT MAJOR COMP/60-Months/100,000 Miles		\$ 620.00
SRV CONTRACT, CMS ENG/AFT To 60-Months/100,000 Miles		\$ 4,380.00
Service Contract, Allison Transmission ETC 2 Year, 5 Year Total Coverage		\$ 1,264.00
Additional Freight		
		\$ -
		\$ -
Additional Floorplan		
Flooring Interest, Additional, 30, For Delivery and Net 30 Days Term		\$ 411.00
		\$ -
Additional Fees & Taxes		
		\$ -
		\$ -
Total Sourcewell Customer Price FOB Anchorage, Alaska		\$ 102,657.12

Terms: Sourcewell quoted price is FOB Anchorage, Alaska. Price does not include fees for title and registration. Price is valid for 30 Days. Please allow 180 Days for delivery.



NJPA VENDOR CONTRACT SUMMARY – Navistar

DATE November 15, 2016	RFP # 081716
AWARDED CONTRACT NUMBER 081716-NVS	NJPA RFP TITLE & CATEGORY CLASS 6, 7, AND 8 CHASSIS WITH RELATED EQUIPMENT, ACCESSORIES, AND SERVICES
CONTRACT PERIOD November 15, 2016 – November 15, 2020	PRICING MODEL Percent Discount Off List: 31%-47%
DESCRIPTION Class 6-8 Chassis	
VENDOR NAME AND ADDRESS Navistar 2701 Navistar Drive Lisle, IL 60532 www.navistar.com	VENDOR CONTACT Martin White 331-332-2370 martin.white@navistar.com

NJPA CONTRACTS CONSIST OF THE FOLLOWING DOCUMENTS "Contract" as used herein shall mean this RFP, pricing, and fully executed forms P, C, D and E ("Acceptance and Award") with final terms and conditions. Request for Proposal (RFP) Contract Acceptance & Award Pricing and Forms P and C - Available upon request from the NJPA Contract Manager	RELATED CONTRACT DOCUMENTATION Affidavit of Advertisement Proposal Opening Witness Page Proposal Evaluation
--	---

NJPA INFORMATION

NJPA CONTACT Andy Campbell	TITLE NJPA Contract Administrator
PHONE 218-895-4145	EMAIL Andy.campbell@njpacoop.org
ADDRESS 202 12th Street NE, P.O. Box 219, Staples, MN 56479	WEBSITE www.njpacoop.org

National Joint Powers Alliance®

Contract Purchasing Department



Compliant, Competitive, and Convenient

Contracts for government, education, and nonprofits

CONTRACT # 081716-NVS

COMPLIANT

- Trusted process satisfies bid requirements
- Government agency that works like you
- Achievement of Excellence in Procurement recipient



COMPETITIVE

- Buying power of 50,000 members
- Contracts offer ceiling-based pricing & volume discounts



CONVENIENT

- Easy, no-cost membership
- Full catalog of class 4/5, 6, 7 & 8 International® Chassis

Contact your local International® Dealer or any International® Government Sales Manager with questions:

Randy Jones
West
(214) 629-1072

Peter McGrath
South
(407) 761-3305

Paul Wagoner
North
(216) 544-2021

Martin White
Contract Holder
(312) 339-2249

**For contract documents and member information,
visit Sourcewell-mn.gov or call (887) 585-9703**

A. CALL TO ORDER

A regular meeting of the Palmer City Council was held on July 14, 2020, at 7:00 p.m. in the Council Chambers, Palmer, Alaska. Mayor DeVries called the meeting to order at 7:00 p.m.

B. ROLL CALL

Due to COVID-19 Mayor DeVries was present in the Council Chambers while the Council Members participated in the meeting by teleconference.

Comprising a quorum of the Council, the following were present:

Edna DeVries, Mayor	Linda Combs, Deputy Mayor (participated by teleconference)
Julie Berberich (participated by teleconference)	Sabrina Combs (participated by teleconference)
Richard W. Best (participated by teleconference)	Jill Valerius (participated by teleconference)
Steve Carrington (participated by teleconference)	

City Clerk Alley took the roll call, Deputy Mayor L. Combs was absent.

Staff in attendance were the following:

John Moosey, City Manager	Michael Gatti, City Attorney (participated by teleconference)
Norma I. Alley, MMC, City Clerk	Kara Johnson, Deputy City Clerk

C. PLEDGE OF ALLEGIANCE

The Pledge of Allegiance was performed.

D. APPROVAL OF AGENDA

1. Approval of Consent Agenda
 - a. Introduction of **Ordinance No. 20-007**: Suspending Ordinance No. 18-004 Pertaining to Palmer Municipal Code Chapter 8.09 Regarding the Distribution of Single-Use Disposable Plastic Shopping Bags During the State of Emergency Order Regarding the COVID-19 Pandemic
 - b. **Action Memorandum No. 20-051**: Authorizing the City Manager to Negotiate and Enter into a Contract with Bering Marine Corporation for the Purchase and Delivery of 175 Tons of Road Salt in the Amount of \$29,452.50
2. Approval of Minutes
 - a. June 9, 2020, Regular Meeting

Main Motion: To Approve the Agenda, Consent Agenda, and Minutes

Moved by:	S. Combs
Seconded by:	Berberich

Primary Amendment #1: To Move Ordinance No. 20-007 to New Business on Agenda

Moved by:	Valerius
Seconded by:	S. Combs
Vote:	4 Yes/3 No (Best, Carrington, DeVries)
Action:	Motion Carried

Vote on Motion: To Approve the Agenda, Consent Agenda, and Minutes, as Amended

Vote:	Unanimous
Action:	Motion Carried

E. REPORTS

1. City Manager’s Report

City Manager Moosey highlighted his written report.

2. City Clerk’s Report

City Clerk Alley reported the following:

- City Council Nominating Petitions were available for pick-up;
- Fire Department’s invitation to the Council to attend one of their Monday training sessions;
- Updated on the referendum petition process;
- Precinct 11-070’s move to Mat-Su Borough Gym;
- Update on recruitment of the Election Worker position;
- Title 17 appeal hearing application was received from U-Haul regarding their CUP request;
- Changes in City Hall to avoid cluster gatherings and ensure timely information sharing amongst Council; and
- Update on Absentee By-Mail Ballot requests.

1. Mayor’s Report

- a. Palmer Pride Awards Nominations
- b. AML Position Statements

Mayor DeVries highlighted her written report and requested Council to contact their Palmer Pride Award Nominees and provide input on AML Positions Statements.

3. City Attorney’s Report

None.

F. AUDIENCE PARTICIPATION

Ms. Ailis Vann, Palmer Chamber of Commerce Executive Director, provided an update on Chamber activities including Friday Fling, Midsummer Garden and Art Faire, Palmer Wine Walk, and Shop Palmer.

Mayor Devries called a recess at 8:08 p.m. The meeting reconvened at 8:18 p.m. City Clerk Alley took roll call. Council Member Best was absent.

G. UNFINISHED BUSINESS

- 1. **Information Memorandum No. 20-006:** Committee of the Whole for General Discussion Regarding Code of Ethics for City Council (Note: action may be taken following the Committee of the Whole)

The Council entered into Committee of the Whole at 8:18 p.m.

Council Member Best joined the meeting at 8:21 p.m.

Topics addressed included:

- Code of Ethics only pertaining to City Council and removing references to staff;

- Applicability as a body or only to individuals;
- History of Title 29 Ethics Code; and
- Inclusion of social media policy.

The Committee of the Whole was adjourned at 9:09 p.m. and the regular meeting reconvened at 9:09 p.m.

Main Motion: To Direct the City Attorney to Draft Code of Ethics Language Using the City of Belmont, CA

Moved by:	Carrington
Seconded by:	L. Combs
Vote:	Unanimous
Action:	Motion Carried

2. **Information Memorandum No. 20-007:** Committee of the Whole for General Discussion Regarding CARES Act Funding (Note: action may be taken following the Committee of the Whole)

Mayor DeVries requested discussion on Information Memorandum No. 20-007 be held under the Public Hearing for Resolution No. 20-017. Hearing no objection from Council, no discussion ensued.

H. PUBLIC HEARING

1. **Resolution No. 20-017:** Authorizing the Appropriation of Expenditures for the Coronavirus Aid, Relief, and Economic Security Act (CARES Act) Funds

City Manager Moosey presented the staff report.

Mayor DeVries opened the public hearing on Resolution No. 20-017. Hearing no objections from the Council, Mayor Devries closed the public hearing.

Main Motion: To Approve Resolution No. 20-017

Moved by:	S. Combs
Seconded by:	Valerius
Vote:	Unanimous
Action:	Motion Carried

2. **Resolution No. 20-018:** Accepting and Appropriating the U.S. Department of Justice 2020 Cops Hiring Program Grant in the Amount of \$125,000.00 to Fund a New Patrol Officer Position for the Palmer Police Department for a Three-Year Period from July 1, 2020, through June 30, 2023

Mayor DeVries opened the public hearing on Resolution No. 20-018. Hearing no objections from the Council, Mayor Devries closed the public hearing.

Main Motion: To Approve Resolution No. 20-018

Moved by:	L. Combs
Seconded by:	S. Combs
Vote:	Unanimous
Action:	Motion Carried

I. NEW BUSINESS

1. **Action Memorandum No. 20-052:** Authorizing the City Manager to Negotiate and Purchase Insurance Coverage for the Period of July 1, 2020, Through June 30, 2021, per the Premium Quote Submitted by the City’s Insurance Broker, RISQ Consulting

Main Motion: To Approve Action Memorandum No. 20-052

Moved by:	Carrington
Seconded by:	S. Combs
Vote:	Unanimous
Action:	Motion Carried

2. Introduction of **Ordinance No. 20-007**: Suspending Ordinance No. 18-004 Pertaining to Palmer Municipal Code Chapter 8.09 Regarding the Distribution of Single-Use Disposable Plastic Shopping Bags During the State of Emergency Order Regarding the COVID-19 Pandemic

Mayor DeVries provided the report and fielded questions regarding Fred Meyer’s request for the suspension (see official meeting packet for letter).

Main Motion: Accept the Introduction of Ordinance No. 20-007 and Set to Public Hearing on July 28, 2020

Moved by:	Best
Seconded by:	L. Combs
Vote:	Unanimous
Action:	Motion Carried

J. RECORD OF ITEMS PLACED ON THE TABLE

City Clerk Alley reported public testimony and a letter from Fred Meyer were Items Placed on the Table.

K. AUDIENCE PARTICIPATION

Mr. Mike Chmielewski testified on the topic of Code of Ethics and transparency.

L. COUNCIL MEMBER COMMENTS

No direction was given to staff for legislation to be placed on a future agenda.

M. ADJOURNMENT

With no further business before the City Council, the meeting adjourned at 10:05 p.m.

Approved this ____ day of _____, 2020.

Norma I. Alley, MMC, City Clerk

Edna B. DeVries, Mayor

White Paper: COVID-19 GRANT PROGRAM & PUBLIC OFFICIALS ACCESSABILITY

John Moosey
City Manager
August 4, 2020

Background

On May 26, 2020, Palmer City Council approval (Resolution No 20-015) accepting the City's share of Coronavirus Relief Funds in the amount of \$7,566,546.24. It was followed with the approval Resolution No. 20-017. This appropriated expenditures of the CARES Act Funds.

Developed program consists of the following:

- Small Business CARES Grants
- Non-profit CARES Grants
- Non-profit CARES Competitive Grants
- City Utility Abatement
- City Mitigation Expenditures
- City Resiliency and Recovery

City Code 2.06.130 Conflict of Interest and Voting states the following:

“C. A municipal employee or official, other than a member of the governing body, may not participate in an official action in which the employee or official has a substantial financial interest;

D. The presiding officer shall declare all votes; but if any member doubts a vote, the presiding officer, without further debate upon the question, shall request the members voting in the affirmative and negative respectively to so indicate, and shall declare the result;

E. The vote upon all matters considered by the council shall be taken by yes or no votes which shall be entered upon the record, except that when the vote is unanimous, it shall be necessary only to so state. (Ord. 648 § 5, 2005)”

Grant Program & Public Officials Accessibility

Issue 1. Declaring A Potential Conflict

The City Managers recommendation as issued in memorandum dated July 24, 2020 is for each City Council Member to declare a potential conflict. The purpose is three-fold. I believe that each City Council Member should have an opportunity to access the grant program. It was designed to allow elected officials, family members and associates to participate at the same level as every other community member.

Secondly there is not a definition of substantial interest.

Finally, this is a new program. In the best interests for transparency and public notification, the City Manager believes this additional notice will protect the trust between the City Government and the people we serve.

In determining this potential conflict, the City of Palmer received further clarification on this matter from DCRA regarding Grant Guidance for Local Governments Updated as of July 20, 2020.

Does the Article 14 Conflict of Interest Provision (Attachment C-Standard Provisions) apply to funds generally available to the public and subject to fixed eligibility standards?

No. Article 14 of the grant agreement precludes officers, employees, etc... of the grantee from having a direct/indirect personal or pecuniary gain or interest in any contract, subcontract, or the proceeds thereof for work to be performed in connection with the "project" funded by the grant. This provision is designed to prevent an officer or employee of the grantee from awarding a contract or subcontract and then receiving a direct/indirect benefit from the award of the contract/subcontract.

For example, if a local government was going to use grant funds to construct temporary medical facilities, and the Mayor owned a construction company, grant funds could not be used to compensate the Mayor's construction company for construction of the temporary medical facilities. This provision does not preclude officers, employees, etc... of the grantee from participating in programs implemented by the local government, generally available to the public, and subject to fixed eligibility standards.

Issue 2. Program Designed To Avoid Conflicts

There are procedures put in place to avoid a potential conflict of interest.

The City Council approved the overall grant program recommended by the City Manager. The program was created by staff without City Council participation in the program development. The City Council gave the sole authority to the City Manager to review and award the grants without City Council approval. This essentially built a wall between the program and the City Council.

The grant program was designed to award every applicant that fell into a broad category. For example, the City Utility Abatement Program will award every City utility customer that declares a negative impact regarding the COVID-19 pandemic. The business and non-profit grant program was designed to award every applicant that met general criteria. There is no competition for those dollars. The program was designed to positively impact every city business and non-profit that could claim harm from the pandemic.

Charter Section 3.6 Meetings of the council.

- (a) All meetings of the Council shall be public meetings and the public shall have a reasonable opportunity to be heard.
- (b) Reasonable public notice shall be given for all meetings of the Council. The notice shall include the date, time, and place of the meeting and if the meeting is by teleconference, the location of the teleconferencing facilities that will be used.
- (c) Four members of the Council shall be a quorum for the transaction of business. In the absence of a quorum, any member less than a quorum may adjourn a meeting to a later date.
- (d) The vote of at least four members shall be required for official action by the Council, unless a larger majority is required by law. The vote upon all matters considered by the Council shall be taken by "Yes" or "No" vote which shall be entered upon record, except that, where the vote is unanimous, it shall be necessary only so to state.
- (e) The Council shall determine its own rules and order of business and shall keep minutes of all its proceedings. The minutes of each Council meeting shall be signed by the Clerk and countersigned by the Mayor.
- (f) No Council member may vote on any question upon which he or she has a substantial direct or indirect financial interest. Otherwise, each Council member shall vote on each question before the Council for determination, unless excused by the affirmative vote of all remaining members able to vote on the question. If a question is raised under this section at any Council meeting, the question shall be determined before the main question shall be voted on. Council members affected may not vote on such determination.

PMC 2.06.130 Conflict of interest and voting.

- A. A member of the council shall declare a substantial financial interest the member has in an official action and ask to be excused from a vote on the matter;
 - 1. The presiding officer shall rule on the request to be excused from the vote;
 - 2. The decision of the presiding officer on the request may be overridden by a majority vote;
- B. Declaration to be excused must be made before the vote, and shall be decided without debate;
- C. A municipal employee or official, other than a member of the governing body, may not participate in an official action in which the employee or official has a substantial financial interest;
- D. The presiding officer shall declare all votes; but if any member doubts a vote, the presiding officer, without further debate upon the question, shall request the members voting in the affirmative and negative respectively to so indicate, and shall declare the result;
- E. The vote upon all matters considered by the council shall be taken by yes or no votes which shall be entered upon the record, except that when the vote is unanimous, it shall be necessary only so to state. (Ord. 648 § 5, 2005)

Mayor's Memo
Council Meeting report for council Meeting
on August 11, 2020

Events

Alaska State Fair has scheduled several events, please check their Facebook or website to see the calendar of events.

Friday Fling continues.

Alaska Municipal League Summer meeting via zoom – August 10-14.

Agenda setting meeting August 12.

Mayor/Managers meeting on August 20

9-1-1 Task Force meeting via webex at least once many times twice a week – report due by September 1 to the Governor

Green Day Gallop – August 8 –

Basic Needs – zoom meeting – August 17

We want and value your input and participation.

Edna DeVries Mayor w/t 907-355-9933

eDEVRIES@PALMERAK.ORG

**City of Palmer
Resolution No. 20-019**

Subject: Issuance of Utility Revenue Bonds in the Principal Amount Not to Exceed \$8,000,000.00 to Finance Wastewater Utility Improvements, as Required by Federal Consent Decree, and to Submit the Question of the Issuance of such Bonds to the Qualified Voters of the City at the October 6, 2020 City Election

Agenda of: July 28, 2020 – Introduction and 1st Public Hearing
August 11, 2020 – 2nd Public Hearing

Council Action: **Approved** **Amended:** _____
 Defeated



Originator Information:

Originator: Chris Nall, Director of Public Works

Department Review:

Route to:	Department Director:	Signature:	Date:
_____	Community Development	_____	_____
_____	Finance	_____	_____
_____	Fire	_____	_____
_____	Police	_____	_____
✓	Public Works		07/07/2020

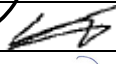
Approved for Presentation By:

	Signature:	Remarks:
City Manager		_____
City Attorney		_____
City Clerk		_____

Certification of Funds:

Total amount of funds listed in this legislation: \$ **8,000,000.00**

This legislation (✓):

✓	Creates revenue in the amount of:	\$ <u>8,000,000.00</u>
<input type="checkbox"/>	Creates expenditure in the amount of:	\$ _____
<input type="checkbox"/>	Creates a saving in the amount of:	\$ _____
<input type="checkbox"/>	Has no fiscal impact	

Funds are (✓):

<input type="checkbox"/>	Budgeted	Line item(s): _____
✓	Not budgeted	_____

Director of Finance Signature: 

Attachment(s):

- Resolution No. 20-019

Summary Statement/Background:

In accordance with the City of Palmer's Federal Consent Decree (Civil Action No: 3:16-cv-00204-TMB), the City is required to install and operate two Secondary Clarifiers units at the Palmer Wastewater Treatment Plant.

The clarifiers are to be of sufficient treatment and settling capacity to enable the facility to meet all effluent limits in the its current APDES permit or any subsequent APDES permits that may be issued by EPA or ADEC.

The system shall be configured to allow for the future addition of a third clarifier, if necessary, to support treatment of a future maximum monthly flow of 1.5 Million Gallons a Day.

Administration's Recommendation:

Approve Resolution No. 20-019.

LEGISLATIVE HISTORY

Introduced by: City Manager Moosey
1st Public Hearing Date: July 28, 2020
2nd Public Hearing: August 11, 2020
Action:
Vote:

Yes:	No:

CITY OF PALMER, ALASKA

Resolution No. 20-019

A Resolution of the City Council of the City of Palmer, Alaska, Authorizing the City of Palmer to Issue Utility Revenue Bonds in the Principal Amount Not to Exceed \$8,000,000.00 to Finance Wastewater Utility Improvements, as Required by Federal Consent Decree and to Submit the Question of the Issuance of Such Bonds to the Qualified Voters of the City at the October 6, 2020, Regular City Election

WHEREAS, the City of Palmer, Alaska (the "City") is a home rule city and under Section 11 of Article X of the Alaska Constitution may exercise all legislative power not prohibited by law or the charter of the City, and the City has determined that the matters set forth in this resolution are not prohibited by law or the charter; and

WHEREAS, Section 11.1(a)(2) of the Palmer City Charter authorizes the City to issue revenue bonds which are secured only by the revenue producing public utilities and do not constitute a general obligation or debt of the City, provided that such revenue bonds shall be authorized by the council and ratified by a majority of the qualified voters of the City; and

WHEREAS, it is necessary and in the best interest of the City and its residents that the City authorize the issuance of utility revenue bonds for the purposes described in this Resolution.

NOW, THEREFORE, BE IT ORDAINED BY THE CITY COUNCIL OF THE CITY OF PALMER, ALASKA, that:

Section 1. It is hereby determined to be for a public purpose and in the public interest of the City to incur utility revenue bonded indebtedness in an amount not to exceed Eight Million Dollars (\$8,000,000.00), for the purpose of financing capital improvements to the City's wastewater utility facilities and to pay costs of issuance of such bonds.

Section 2. The City is authorized to borrow the sum of not to exceed Eight Million Dollars (\$8,000,000.00) to finance the capital improvements described in Section 1, and the borrowing shall be evidenced by the issuance of utility revenue bonds of the City. The revenues of the City wastewater utility shall be pledged for payment of the principal of and interest on the bonds. The bonds shall not be a general obligation of the City, and neither the full faith and credit nor the taxing power of the City shall be pledged to the payment of the principal of or interest on the bonds.

Section 3. The City shall submit the following proposition to the qualified voters of the City at the October 6, 2020, regular City election. The proposition must receive an affirmative vote from a majority of the qualified voters voting on the question to be approved.

Attachment(s)

- Resolution No. 20-005-A

Summary Statement:

The mid-year budget amendment adjusts revenues and expenditures/expenses for additional revenues received, grants and reimbursed expenditures.

The General Fund (01) revenue adjustments include the following:

- Increase in Library Grants for 2020/2021 PLA Grant.
- Increase in SART Revenue reimbursed from AST.
- Increase in Misc Income-Public Works for monies received due to mechanical issues with Airport new Wausau MP318 snow removal equipment.
- Increase in Misc Income-Public Safety due to forfeit of lost property and evidence from police department over several years.

The General Fund (01) expenditure adjustments include the following:

- Increase in Police Department Services line item due to SART expenses.
- Increase in Public Works Vehicle Supplies for filters and parts purchased for Airport new Wausau MP318 snow removal equipment.
- Increase in Library Grant Operating expenses for 2020/2021 PLA Grant.

The Water/Sewer Fund (02) decrease in Water Equipment moved to Water/Sewer Capital Projects Fund (24) for repairing the Bailey Hill Water Reservoir.

The Airport Fund (03) increases to revenues for Misc Income due to ENSTAR main extension refund from 2009 and settlement with Pruhs Construction. Increase to expenses to repair and maintenance for the reconditioning of the hayfields and watering of the hayfields as approved in AM 20-033 and AM 20-034.

The Airport Capital Projects Fund (30) increases to revenue and expenses for approved AM 20-035 for the FAA CARES Grant for \$30,000, AM 20-036 for the FAA Avigation Easement Planning Study for \$109,810 and additional FAA funds that were available for the counter weights for the FAA Airport Equipment Grant in the amount of \$12,809.

Administration's Recommendation:

Approve Resolution No. 20-005-A amending the 2020 City of Palmer Budget for the fiscal year ending December 31, 2020.

LEGISLATIVE HISTORY

Introduced by: City Manager
Date: August 11, 2020
Public Hearing: August 11, 2020
Action:
Vote:

Yes:	No:

CITY OF PALMER, ALASKA

Resolution No. 20-005-A

A Resolution of the Palmer City Council Amending the Budget for the City of Palmer, Alaska for the Fiscal Year Ending December 31, 2020

WHEREAS, at the August 11, 2020 council meeting the manager presented budget amendments and the City Council approved increasing the General Fund (01) revenues \$43,061 and increasing General Fund (01) expenditures \$20,171 for a net increase of \$22,890; and

WHEREAS, at the August 11, 2020 council meeting the manager presented budget amendments and the City Council approved increasing the Airport Fund (03) revenues \$42,690 and increasing Airport Fund (03) expenses \$35,000 for a net increase of \$7,690; and

WHEREAS, at the August 11, 2020 council meeting the manager presented budget amendments and the City Council approved increasing Water-Sewer Capital Projects Fund (24) revenues \$30,000 and increasing the Water-Sewer Capital Projects Fund (24) expenses \$30,000; and

WHEREAS, at the August 11, 2020 council meeting the manager presented budget amendments and the City Council approved increasing the Airport Capital Fund (30) revenues \$149,330 and increasing the Airport Capital Fund (30) expenses \$149,330; and

NOW, THEREFORE, BE IT RESOLVED by the Palmer City Council hereby amends the 2020 budget as follow:

Line item description	Current 2020 Budget	Proposed Amendment	Amended 2020 Budget
GENERAL FUND (01)			
General Fund (01) Revenues:			
01-00-00-3343 Library Grants	\$ 6,900	\$ 7,000	\$ 13,900
01-00-00-3685 SART Revenue	\$ 0	\$ 8,171	\$ 8,171
01-00-00-3687 Misc Income – Public Works	\$ 0	\$ 17,870	\$ 17,870
01-00-00-3689 Misc Income – Public Safety	\$ 0	\$ 10,020	\$ 10,020
TOTAL GENERAL FUND REVENUE AMENDMENTS		\$ 43,061	
General Fund (01) Expenditures:			
Police Department:			
01-12-10-6029 Services	\$ 35,000	\$ 8,171	\$ 43,171
Total Police Department Amendments		\$ 8,171	

Line item description	Current 2020 Budget	Proposed Amendment	Amended 2020 Budget
Public Works Department:			
01-17-80-6042 Vehicle Supplies	\$ 15,000	\$ 5,000	\$ 20,000
Total Public Works Department Amendments		\$ 5,000	
Library:			
01-19-23-6044 Grant Operating Expenses	\$ 6,900	\$ 7,000	\$ 13,900
Total Library Amendments		\$ 7,000	
TOTAL GENERAL FUND EXPENDITURES AMENDMENTS		\$ 20,171	
WATER/SEWER FUND (02)			
Expenses:			
02-01-10-6053 Equipment	\$ 40,000	\$ (30,000)	\$ 10,000
02-01-10-6078 Transfers Out	\$ 105,000	\$ 30,000	\$ 135,000
TOTAL WATER/SEWER FUND EXPENSE AMENDMENTS		\$ 0.00	
AIRPORT FUND (03)			
Revenues:			
03-00-00-3690 Miscellaneous Income	\$ 0	\$ 42,690	\$ 42,690
TOTAL AIRPORT FUND REVENUE AMENDMENTS		\$ 42,690	
Expenses:			
03-01-10-6045 Repairs & Maintenance	\$ 30,000	\$ 35,000	\$ 65,000
TOTAL AIRPORT FUND EXPENSE AMENDMENTS		\$ 35,000	
WATER-SEWER CAPITAL PROJECTS FUND (24)			
Revenues:			
24-00-00-3673 Transfers From Other Funds	\$ 150,000	\$ 30,000	\$ 180,000
TOTAL WATER SEWER CAPITAL PROJECTS REVENUE AMENDMENTS		\$ 30,000	
Expenses:			
24-60-01-6030 Bailey Hill Reservoir	\$ 78,265	\$ 30,000	\$ 108,265
TOTAL WATER SEWER CAPITAL PROJECTS FUND EXPENSE AMENDMENTS		\$ 30,000	
AIRPORT CAPITAL PROJECTS FUND (30)			
Revenues:			
30-00-00-3381 FAA Equip Grant 3-02-021	\$ 3,289	\$ 9,520	\$ 12,809
30-00-00-3383 Avigation Easement Grant (Ph1)	\$ 0	\$ 109,810	\$ 109,810
30-00-00-3384 CARES Act Grant (FAA)	\$ 0	\$ 30,000	\$ 30,000
TOTAL AIRPORT CAPITAL PROJECTS REVENUE AMENDMENTS		\$ 149,330	
Expenses:			
30-03-10-7130 FAA Equipment Grant Exp	\$ 3,289	\$ 9,520	\$ 12,809
30-03-10-7132 FAA Avigation Easement Grant Exp	\$ 0	\$ 109,810	\$ 109,810
30-03-10-7133 FAA CARES Act Grant Exp	\$ 0	\$ 30,000	\$ 30,000
TOTAL AIRPORT CAPITAL PROJECTS EXPENSE AMENDMENTS		\$ 149,330	

Approved by the Palmer City Council this ____ day of _____, 2020.

Edna B. DeVries, Mayor

Norma I. Alley, MMC, City Clerk