

Mayor Edna B. DeVries
 Deputy Mayor Richard W. Best
 Council Member Steve Carrington
 Council Member Sabrena Combs
 Council Member David Fuller
 Council Member Brad Hanson
 Council Member Pete LaFrance

City Attorney Michael Gatti
 City Clerk Norma I. Alley, MMC
 City Manager Nathan Wallace

City of Palmer, Alaska
Special City Council Meeting
May 1, 2018, at 7 PM
 City Council Chambers
 231 W. Evergreen Avenue, Palmer
www.cityofpalmer.org

AGENDA

A. CALL TO ORDER

B. ROLL CALL

C. PLEDGE OF ALLEGIANCE

D. APPROVAL OF AGENDA

1. Approval of Consent Agenda
 - a. Introduction to **Ordinance No. 18-004**: Enacting Palmer Municipal Code Chapter 8.09 Prohibiting the Distribution of Single-Use Disposable Plastic Shopping Bags and Amending the City of Palmer Fine Schedule Page 3
 - b. **Action Memorandum No. 18-054**: Authorizing the City Manager to Execute Change Order No. 2 with Roger Hickel Contracting, Inc., to Install a 3' Stainless-Steel Spool Piece in the ALP Lines as Part of the Wastewater Treatment Plant Facility Plan Update, in the Amount of \$15,476.00 Page 23
 - c. **Action Memorandum No. 18-055**: Accepting Commission Member Douglas Cruthers' Resignation from the Planning and Zoning Commission Page 33
 - d. **Action Memorandum No. 18-056**: Approving the Cancellation of the May 8, 2018, Regular Council Meeting..... Page 35
2. Approval of Minutes of Previous Meetings
 - a. December 5, 2017, Special Meeting Page 37

E. COMMUNICATIONS AND APPEARANCE REQUESTS

1. Presentation of a Proclamation Declaring May 2018 as Bike Month..... Page 43
2. Presentation of a Proclamation Declaring April 30, 2018, as Olympian Day Page 44
3. Presentation of a Proclamation Declaring May 2018 as Older Americans Month Page 45
4. Presentation of a Proclamation Declaring May 19, 2018, as National Kids to Parks Day Page 46

F. REPORTS

1. City Manager's Report
2. City Clerk's Report Page 47
3. Mayor's Report
4. City Attorney's Report

G. AUDIENCE PARTICIPATION

H. PUBLIC HEARING

- 1. **Ordinance No. 18-003:** Amending the Palmer Municipal Code Title 18 Pertaining to Absentee Voting by Electronic Transmission Page 51
- 2. **Resolution No. 18-013:** Accepting and Appropriating the 2018 Volunteer Fire Assistance Grant from the State of Alaska, Department of Natural Resources, Division of Forestry in the Amount of \$7,500.00 for the Purchase of Wildland Fire Personal Protective Clothing and Wildland Firefighting Equipment Page 57

I. ACTION MEMORANDA

- 1. **Action Memorandum No. 18-057:** Approving an Exception to the City of Palmer Charter Section 2.3 Allowing Council Member Hanson to be Eligible for Employment for Which a Salary is Paid by the City Prior to One Year Elapsing Following His Term..... Page 63

J. NEW BUSINESS

- 1. **Information Memorandum No. 18-001:** Updating the Council on the Governor’s Commuter Rail Advisory Task Force..... Page 65

K. RECORD OF ITEMS PLACED ON THE TABLE

L. AUDIENCE PARTICIPATION

M. COUNCIL MEMBER COMMENTS

N. ADJOURNMENT

Tentative 2018 Palmer City Council Meetings

Meeting Date	Meeting Type	Time	Notes
May 8	Regular	7 pm	CANCELLED
May 22	Regular	7 pm	
June 12	Regular	7 pm	
June 26	Regular	7 pm	
July 10	Special	6 pm	Mid-Year Budget Review
July 10	Regular	6 pm	
July 24	Special	6 pm	2019 Budget Planning Priorities
July 24	Regular	7 pm	
Aug 14	Regular	7 pm	
Aug 28	Regular	7 pm	

**City of Palmer
Ordinance No. 18-004**

Subject: Enacting Palmer Municipal Code Chapter 8.09 Prohibiting the Distribution of Single-Use Disposable Plastic Shopping Bags and Amending the City of Palmer Fine Schedule

Agenda of: May 1, 2018 - Introduction

Council Action: **Adopted** **Amended:** _____
 Defeated



Originator Information:

Originator: Council Members Pete LaFrance and Sabrena Combs

Department Review:

Route to:	Department Director:	Signature:	Date:
_____	Community Development	_____	_____
_____	Finance	_____	_____
_____	Fire	_____	_____
_____	Police	_____	_____
_____	Public Works	_____	_____

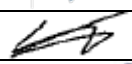
Approved for Presentation By:

	Signature:	Remarks:
City Manager		_____
City Attorney		_____
City Clerk		_____

Certification of Funds:

Total amount of funds listed in this legislation: \$ 0.00

This legislation (√):

- Creates revenue in the amount of: \$ _____
- Creates expenditure in the amount of: \$ _____
- Creates a saving in the amount of: \$ _____
- Has no fiscal impact

Funds are (√):

- Budgeted Line item(s): _____
- Not budgeted _____

Director of Finance Signature:  _____

Attachment(s):

- Ordinance No. 18-004
- Public Testimony

Summary Statement/Background:

Plastic, single-use, disposable shopping bags are a problem in the City of Palmer. Their prevalence as litter is often noted during the annual city clean up, and at any given time they can be seen tangled in trees, bushes and fences around town. Additionally, they pose a real danger to both terrestrial and aquatic wildlife and have been found in the digestive tracts of many local animals. Plastic bag bans in other regions have been shown to reduce plastic bag litter by 72% and are known to effectively help protect wildlife and pets. It is therefore in the best interest of the city to restrict the free distribution of disposable shopping bags thinner than .4 mils within the city limits. Further, a fine schedule is recommended for the distribution of single-use disposable plastic shopping bags thinner than .4 mils.

Administration's Recommendation:

Adopt Ordinance No. 18-004 Enacting Palmer Municipal Code Chapter 8.09 Prohibiting the Distribution of Single-Use Disposable Plastic Shopping Bags.

LEGISLATIVE HISTORY

Committee of the Whole: February 27, 2018
Introduced by: Council Members LaFrance and Combs
Date: May 1, 2018
Public Hearing:
Action:
Vote:

Yes:	No:

CITY OF PALMER, ALASKA

Ordinance No. 18-004

An Ordinance of the Palmer City Council Enacting Palmer Municipal Code Chapter 8.09 Prohibiting the Distribution of Single-Use Disposable Plastic Shopping Bags and Amending the City of Palmer Fine Schedule

WHEREAS, the use of single-use carry-out disposable plastic shopping bags in the city of palmer ("city") creates a burden on the environment, endangers wildlife, and has been shown to be harmful to bodies of water and problematic for solid waste management; and

WHEREAS, to decrease the number of littered disposable plastic shopping bags in the city, it is necessary to restrict general use; and

WHEREAS, it is in the best interest of the health, safety, and welfare of all residents to restrict the use of single-use disposable plastic shopping bags; and

WHEREAS, plastic carryout bags do not biodegrade, create problematic environmental issues, and frequently escape from trash containers and landfills creating a burden on residents and the City for clean-up.

THE CITY OF PALMER, ALASKA, ORDAINS:

Section 1. Classification. This ordinance shall be permanent in nature and shall be incorporated into the Palmer Municipal Code.

Section 2. Severability. If any provisions of this ordinance or application thereof to any person or circumstances are held invalid, the remainder of this ordinance and the application to the other persons or circumstances shall not be affected thereby.

Section 3. Palmer Municipal Code is hereby amended to read as follows (new language is underlined and deleted language is ~~stricken~~):

Chapter 8.09.010 Definitions

Any word, term, or phrase not defined in this section shall have its ordinary and common meaning. The following words, terms, and phrases, when used in this chapter, shall have the meanings ascribed to them in this section:

"Affected establishment" means any retail or commercial business facility located inside the city of Palmer that sells goods or prepared food directly to consumers including but not limited to grocery stores, pharmacies, retail stores, and restaurants.

"Single-use plastic disposable shopping bag" means a bag made from plastic or any material not marked or labeled as "biodegradable" or "compostable" that is neither intended nor suitable for continuous reuse and that is less than 4 mils thick, designed to carry customer purchases from the seller's premises.

Chapter 8.09.020 Purpose

The purpose of this chapter is to reduce the generation of waste from single-use plastic disposable shopping bags.

Chapter 8.09.030 Single-use plastic disposable shopping bag prohibited

A. No affected retail establishment may provide to any customer a single-use plastic disposable shopping bag for the purpose of carrying away goods from the point of sale.

B. No person may distribute single-use plastic disposable shopping bags at any city facility or any event held on city property.

Chapter 8.09.040 Exceptions

Exceptions to the prohibition are bags used by customers inside stores:

A. To package bulk items such as fruit, vegetables, nuts, grains, candy or small hardware items such as nails and bolts; and

B. Bags used to contain dampness or leaks from items such as frozen foods, meat, or fish, flowers or potted plants; and

C. Bags used to protect prepared foods or bakery goods; and

D. Bags provided by pharmacists to contain prescription drugs; and

E. newspaper, laundry or dry-cleaning bags; and

F. Bags sold for consumer use, off the seller's premises, for such purposes as the collection and disposal of garbage, pet waste, or yard waste.

Chapter 8.09.050 Fines

A Violation of this chapter is an offense punishable by the fine established in the current, adopted budget.

Section 4. Amendment of city of Palmer Fine Schedule is hereby amended to add a fine schedule for the distribution of single-use plastic disposable shopping bags, as follows:

Palmer Municipal Code (PMC) Title 8 Health & Safety			
Chapter 8.09 Prohibiting the Distribution of Single-Use Disposable Plastic Shopping Bags			
Section Title:	Section Citation:	Fine:	Fine Citation:
Single-use plastic disposable shopping bag prohibited	8.09.030	First Offence: Warning Second Offence: \$100.00 Third Offence: \$300.00	8.09.050

Section 5. Effective Date. Ordinance No. 18-004 shall take effect January 1, 2019.

Passed and approved this ____ day of ____, 2018.

Edna B. DeVries, Mayor

Norma I. Alley, MMC, City Clerk

Norma Alley

From: Alex Papasavas <contact@turkeyredak.com>
Sent: Monday, February 26, 2018 1:31 PM
To: Norma Alley
Subject: Letter for Tuesday Meeting
Attachments: Plastic Bags.doc

Hello Norma,

Attached is a letter to the City Council regarding the meeting tomorrow, Tuesday night. I am not able to attend and ask that the letter be read in my absence.

Please contact me with any questions or clarifications if necessary.

Thank you,
Alex Papasavas, Owner/Manager
Turkey Red
(907) 355-3242



City of Palmer Clerk
nalley@palmerak.org

February 24, 18

To the Palmer City Council,

Thank you for this discussion on finding an alternative to single use plastic bags. As the Owner/Manager of Turkey Red, I am confident in our Palmer community and the Palmer City council to put our heads together to develop a plan that is affordable, has minimum impact on our precious environment and minimum impact especially to those that are currently poverty stricken. As a business owner, looking at the true cost of decisions and actions is imperative in preventing costlier fixes in the future. This is where we are with this issue. Single use bags are cheap & light in weight for easier shipping, but the true cost of their existence is not calculated into the equation. When the cost of damage to wildlife alone is added, that right there makes them too costly. Extending landfills are crazy costly also, so reducing waste saves money. Other cities, states and countries are finding solutions to this problem. Over 15 years ago, London, England made available large reusable heavy-duty plastic weave bags in grocery stores for .50 pence for the lifetime of the bag. If the bag wore out, then the customer could exchange it for a new one at no cost. The first year, less than 10% of customers were using them. Within 5 years, over 90% of customers were using them. The financially advantaged and disadvantaged were both using them.

Reusable cloth bags made from hemp or bamboo is the best option. However, any reusable bag to start the process would be welcomed. We have chosen to use paper bags at our restaurant as well as paper straws. Although paper is also single use, paper bags can be recycled, will break down sooner than plastic and will not harm wildlife if eaten as much as plastic. Reusable bags are a better solution. Reusable cloth bags are the best option.

We would be more than happy to donate, contribute funds etc, for a bulk buy of reusable bags between the City of Palmer and other local businesses. The City of Palmer can have their logo on one side and the businesses can have their logos on the other. I am willing to donate time & money to help this necessary positive change in our community.

As with any new good habit, it takes conscious thought to do it enough to make it so it becomes automatic behavior. We are a diverse and clever community, so developing a habit of using reusable bags is indeed very achievable.

Thank you for your time,
Alex Papasavas

550 S. Alaska ST, STE 100
Palmer, AK 99645
Turkeyredak@gmail.com
(907)746-5544

Norma Alley

From: Brooke Heppinstall <brooke@mtaonline.net>
Sent: Sunday, February 25, 2018 2:42 PM
To: Norma Alley
Cc: 'Brooke Heppinstall'
Subject: plastic bag ban hearing/atten: City clerk
Attachments: Remember the aggravation over the switch from paper bags to plastic.docx

Importance: High

Hi ,

I'd like to weigh in on the bag ban issue, but, I'm leaving for Juneau tomorrow. I asked a local City Council member how to do this and she said to send this attachment to you to be read aloud at the hearing Tuesday night.

Thank you!

Brooke G Heppinstall Kroenung
Palmer, AK

Brooke Heppinstall/ Palmer AK

Remember the aggravation over the switch from paper bags to plastic? Save the forests so we can hang these plastic ones from the trees during the next wind storm! Plastic is a marvelous, too perfect invention. Eventually, it winds up in the food chain, clogs the oceans and storm drains, and makes a general mess. Plastics, in general, are a major and growing source of refuse. Paper bags can be equally bad for the overall environment. So, what we're really talking about is changing behavior from unthinking behavior to a thought process that focuses more attention: Where are my reusable bags?

Reusing stuff is a popular trend when it comes to up-cycled furniture and vintage objects, remaking thrift shop clothing, and showing off our crafty skills. Some entrepreneurs collect stuff to sell to these re-users. If we can change our point of view to value this behavior when it comes to interior design and wearables, perhaps we can do so with our shopping bags.

Personally, I can carry up to 42 pounds in one of my reusable totes. It's easier on my shoulder, doesn't break, and fits into my pocket. Friends can have fun making reusable totes. Towns could have a contest for best local design on a town tote. Businesses could host parties to make reusable totes or put their own logo on a reusable 'gift' tote. Your logo lasts longer on a reusable tote. Gifting totes is good for those in need as well.

Change itself is change resistant. It's tough enough to change our behavior to get off the couch and exercise, but, we can do it. We can learn to remember to bring our reusable totes as well.

Brooke Heppinstall

Norma Alley

From: Debby <debbb@gci.net>
Sent: Tuesday, February 27, 2018 4:42 PM
To: Norma Alley
Subject: Support for plastic bag ban.

Dear Madam Clerk,

I am writing in support of the single use plastic bag **ban** proposal for tonight's meeting. I've lived in the Palmer area for 20 years. I purchase 95% of my groceries and goods in Palmer stores. I always bring my own sturdy reusable bags when I shop. I have been a board member, education committee member, and volunteer for the Valley Community Recycling Solutions for 20 years. I look forward to a community that is not choked by plastic bag debris every time the wind blows. Please include my comments in the record for tonight's meeting.

Thank you,

Debby Broneske

17750 E. Idle Drive, Palmer

Norma Alley

From: Joanie Kirk <joaniekirk@gmail.com>
Sent: Tuesday, February 27, 2018 1:10 PM
To: Norma Alley
Subject: Clerk 2.27.18 council mtg re Plastic Bag discussion

Thank you for the opportunity to address the council.

My name is Joanie Kirk, I am a naturopathic doctor in private practice in downtown Palmer. I am writing to voice my support for plastic bag ban legislation in the City of Palmer.

The health of an environment, a community and its occupants can be assessed in many ways. Water and air quality, health of the wildlife, plant life and human population are indicators of overall well-being or dis-ease.

There is enough evidence that plastic bags cause problems in wildlife, both on land and in water. It 's enough that we harm ourselves with plastics, but the effects of human made petroleum products are literally leaking into and damaging our environment and its occupants. The health issues related to humans exposed to plastics, products of the petrochemical industry is alarming and I am afraid we will see worsening problems in the future.

Banning plastic bags is a step we can take locally to address a more pervasive issue of 'what to do with all of our stuff' in our petroleum dependent culture.

Thank you.

Joanie Kirk, ND

907-707-3604 (c)
www.joaniekirknd.com
joaniekirk@gmail.com

Norma Alley

From: Rose C Smith <akrcviergutz@hotmail.com>
Sent: Tuesday, February 27, 2018 3:44 PM
To: Norma Alley
Cc: Carol Montgomery
Subject: Plastic bags

Since I am not able to attend this evening, I did want to add "my 2 cents".

A revision on the strength of the bags, as well as the fee charge, I think will make people more responsible for their proper use and recycling of.

Thank you.

Rose C Smith
Wasilla, Alaska

Get [Outlook for iOS](#)

Name: (Please Print)	Item Being Addressed	Mailing Address	Contact Info (Phone and/or E-Mail)
PATTI FISHER	PLASTIC BAGS	7362 W. PARKS Hwy #514 WASILLA, 99633	psfisher@gci.net
Denise Christopher	Mayors Run	PO BOX 2690 Palmer, AK 99645	907-745-6401
Diana Zitmanis	Plastic Bags	8650 Blue Mountain Lane Palmer, AK 99645	dianazsings@yahoo.com
Helen Woodings	Plastic Bags	1745 Heritage Palmer, AK 99645	hwoodings@gmail.com
Rob Czarnedzi	Plastic Bags	335 S. Cobb St	907 745-8245
m. kelch...	Video		
SANDY BEL	plastic bag	ISSUE (Ottom wood)	745-2002
Lee Henricks	plastic bags	POB 3454 Palmer	
Susie Hayes	"	P.O. Box 3747 Palmer	
Annette Paas	"	935 Belle Alexia Circle Palmer	
Carol Montgomery	Plastic Bag Ban		
Mollie Boyer	Plastic Bag Ban	POB 317 Palmer 99645	745-6714
Carol MONTGOMERY	plastic bag ban	4542 N. Sember Dr Palmer, AK 99645	355-4451

Norma Alley

From: Lj Messenger <ljsadventure@gmail.com>
Sent: Tuesday, February 27, 2018 8:23 PM
To: Norma Alley
Subject: I support the plastic bag ban

Hello

My name is lj messenger. I am a homeowner here in Palmer. I love our town.

I am in full support of the plastic bag ban. Sorry I was unable to make the meeting tonight.

Thanks

Lj

Sent from my iPhone

Norma Alley

From: Russ Johanson <russjohanson@gmail.com>
Sent: Wednesday, February 28, 2018 8:17 PM
To: Norma Alley
Subject: Please ban plastic bags

Dear Ms. Alley,

My wife and I recently purchased land in Palmer and hope to move from Wasilla in the near future, We always viewed Palmer as more community-driven, and more forward-thinking, than our current town; I am surprised Palmer hasn't already banned plastic bags!

I own land near the dump, and I frequently utilize our wonderful trail network in the area. The damage done by plastic blags blowing from the dump is truly breathtaking, and not in the way that Alaskan scenery should be breathtaking. There are cheap, convenient, environmentally-friendly alternatives to plastic bags - reusable bags. The ubiquitous plastic bags are quite frankly a non-value-added item. Because they damage the landscape, provide no benefit, and are easily replaced with a superior alternative, I support banning plastic bags. I hope you will too.

Thank you,
Russ Johanson MD
Vice President, Mat-Su Emergency Physicians

Norma Alley

From: thomas buckley <fwhitney315@gmail.com>
Sent: Tuesday, February 27, 2018 6:44 PM
To: Norma Alley
Subject: Support limiting bags

I don't think I will make to the meeting tonight, but I fully support controlling the wasteful amount of plastic bags used in Palmer. Palmer is a beautiful community, but the amount of plastic bags I see in the spring is so disheartening. To an extent it's a littering problem, but in the valley I've seen countless winds blow bags out of flatbeds, garbage cans, shopping carts etc. They end up everywhere. Please put political jargon aside and make a decision that will boost personal responsibility and community pride. I love Palmer. Please help take care of it.

Respectfully,
Thomas Buckley
Palmer city resident



550 S. Alaska St., Suite 101, PO Box 45, Palmer, AK 99645
Tel: (907) 745-2880 Fax: (907) 746-4164
www.palmerchamber.org info@palmerchamber.org

March 19, 2018

City of Palmer
231 W. Evergreen Ave.
Palmer, AK 99645

Re: Letter of Support – Eliminating the Distribution of Single Use Plastic Bags

Dear Mayor DeVries and City Council Members,

Tourism is a vital industry in our town and many of our members profit from the annual influx of tourists that come to see our agriculture, animals and beautiful scenery. Many of our restaurants, retail stores and lodging industries depend on these visitors to balance their bottom line.

It is important to keep our city as clean and beautiful as possible so that it mirrors the photos visitors see on the internet and in travel brochures. One only needs to look at the fences, ditches and trees to know that there is a problem with the lightweight flyaway bags that often pollute our city.

The Greater Palmer Chamber of Commerce believes it is in our members' best interest to pass legislation to eliminate the distribution of single-use plastic bags. We support an ordinance to achieve this measure.

The Greater Palmer Chamber of Commerce thanks you for your efforts to beautify our wonderful city.

Respectfully,

Ailis Vann, President
Greater Palmer Chamber of Commerce

RECEIVED

APR 19 2018

City of Palmer

Palmer Downtown Merchants' Association
Palmer, AK 99645

City of Palmer
231 W Evergreen Avenue
Palmer, AK 99645

Dear Mayor DeVries and City Council Members,

Thank you for working towards making Palmer an even better town in which to shop and live. As community members that make our living from our shops and businesses in downtown Palmer, we know the value of living and working in a beautiful and progressive town.

We need to keep our city as clean and beautiful as possible for our family, friends, and visitors that support our businesses. One only has to look at the fences, ditches, and trees to know that there is a problem with the lightweight, flyaway bags that often pollute our City. These flimsy single-use plastic bags are contributing to the plastics particles in our food chain, are dangerous to our health, to animals, and to the future for our children.

We believe it is in the best interests of the businesses and members of the Downtown Merchants' association to pass legislation to eliminate the distribution of single use plastic bags, and we support your ordinance to achieve this.

Thank you for your work to beautify our City.

Sincerely,

Sam Strahan
Madd Matters
Jenice Steh
Necessaire

Palmer Downtown Merchants' Association

Misfit Moffitt's Consignment
Karel Mike's
Just Botanicals
Flower fingers
KNLT-FM
SHANE LAMB GALLERY
Garden Gate - Rosie Jigen
Jamaal
Jonas
Kayle
Ty Walker
Linda L Kelley
Amy Cullen
Mat-Su Valley Cancer Center
DeWise Nelson
The Boutique on Main
Mindy Bena
The Boutique on Main
Amara Daniels

Norma Alley

From: Harvey Bowers <bowers654@gmail.com>
Sent: Wednesday, April 25, 2018 9:11 AM
To: City Clerk
Subject: Plastic Bags comments

We live just east of Seward Meridian Road. We have had several businesses and properties here for many decades.

My wife and I support trying to eliminate or greatly reduce the proliferation of single use plastic bags in Palmer.

We have experienced loss due to ingestion of windblown plastic bags by our reindeer. We have had a 40 year battle with picking up windblown bags on our property.

Harvey also had cancer a number of times and almost died. Researchers have linked micro plastic ingestion to cancer. Plastic breaks down 5 mm or less and is ultimately ingested in food and water. Harvey's cancer was fairly rare but there are over a dozen cases in Mat-Su with a likely environmental trigger. The long term health associated with using plastic is only being tested by its long term use.

Using plastic for only a few minutes seems foolish. Plastic bags may not only be a nuisance but a long term public health and safety issue. Anything the City of Palmer can do to reduce the impact of single use plastic bags would be appreciated.

Thank you for consideration.

Harvey & Sandy Bowers
305 S. Bartlett Circle, Wasilla, AK 99654
email: harvey@agateinn.com

**City of Palmer
Action Memorandum No. 18-054**

Subject: Authorizing the City Manager to Execute Change Order No. 2 with Roger Hickel Contracting, Inc., to Install a 3' Stainless-Steel Spool Piece in the ALP Lines as Part of the Wastewater Treatment Plant Facility Plan Update, in the Amount of \$15,476.00

Agenda of: May 1, 2018

Council Action: **Approved** **Amended:** _____
 Defeated

Originator Information:

Originator: City Manager

Department Review:

Route to:	Department Director:	Signature:	Date:
_____	Community Development	_____	_____
<u> √ </u>	Finance	<u><i>[Signature]</i></u>	<u>4/18/18</u>
_____	Fire	_____	_____
_____	Police	_____	_____
<u> √ </u>	Public Works	<u><i>[Signature]</i></u>	<u>4/9/18</u>

Approved for Presentation By:

	Signature:	Remarks:
City Manager	<u><i>[Signature]</i></u>	_____
City Attorney	<u><i>[Signature]</i></u>	_____
City Clerk	<u><i>[Signature]</i></u>	_____

Certification of Funds:

Total amount of funds listed in this legislation: \$ 15,476.00

This legislation (√):

<input type="checkbox"/>	Creates revenue in the amount of:	\$ _____
<input checked="" type="checkbox"/>	Creates expenditure in the amount of:	\$ <u>15,476.00</u>
<input type="checkbox"/>	Creates a saving in the amount of:	\$ _____
<input type="checkbox"/>	Has no fiscal impact	

Funds are (√):

<input checked="" type="checkbox"/>	Budgeted	Line item(s): <u>24-53-42-6225, 24-53-41-6225</u>
<input type="checkbox"/>	Not budgeted	_____

Director of Finance Signature: *[Signature]*

Attachment(s):

- EJCDC Change Order No.2 with provider cost estimate and drawings.

Summary Statement/Background:

This Change Order addresses a 3' gap in the stainless steel air piping supplied by the manufacturer (Kruger) and the air piping supplied by the contractor (Hickel). The design calls for a stainless steel low pressure airline to run from the aeration blower in the new Control Building out to the diffusers and air sparge lines in the MBBR basins. The design plans for the pre-purchase of the MBBR equipment called for the manufacturer to supply the airlines internal to the MBBRs up to an elevation 3' above the top of the concrete basins; above that point the air piping is supplied by the general contractor. The MBBR manufacturer provided air piping only up to the top of the basins, leaving a 3' gap on a total of 20 drop legs to the aeration system.

This change order also provides an additional 60' of various-sized stainless-steel air piping (4" and 1" pipe).

USDA is already in agreement with this Change Order.

Administration's Recommendation:

To approve Action Memorandum No. 18-054 allowing the City Manager to execute Change Order No.2.

Date of Issuance: March 14, 2018 Effective Date: March 14, 2018
 Owner: City of Palmer, AK Owner's Contract No.:
 Contractor: Roger Hickel Contracting, Inc. Contractor's Project No.: 374
 Engineer: HDR Engineer's Project No.: 10022766
 Project: Wastewater Treatment Facility Improvements Contract Name:

The Contract is modified as follows upon execution of this Change Order:
 Description: Install 3-ft S.S. spool piece in ALP lines where there was a gap in what was supplied by the manufacturer and the contractor. Includes the addition of Qty 14 4" and Qty 6 1" fabricated spools of SS Sch 10 pipe around MBBR catwalk per Drawing 200D301 Key Note #3.

Attachments: *[List documents supporting change]* Change Order Proposal letter from Roger Hickel Contracting, Inc. dated November 13, 2017.

CHANGE IN CONTRACT PRICE	CHANGE IN CONTRACT TIMES <i>[note changes in Milestones if applicable]</i>
Original Contract Price: \$ <u>9,514,000.00</u>	Original Contract Times: Substantial Completion: <u>July 31, 2018</u> Ready for Final Payment: <u>November 30, 2018</u> days or dates
<u>[Increase] [Decrease]</u> from previously approved Change Orders No. <u>1</u> to No. <u>1</u> : \$ <u>33,317.00</u>	<u>[Increase] [Decrease]</u> from previously approved Change Orders No. <u> </u> to No. <u> </u> : <u>No Change</u> Substantial Completion: _____ Ready for Final Payment: _____ days
Contract Price prior to this Change Order: \$ <u>9,547,317.00</u>	Contract Times prior to this Change Order: Substantial Completion: <u>July 31, 2018</u> Ready for Final Payment: <u>November 30, 2018</u> days or dates
<u>[Increase] [Decrease]</u> of this Change Order: \$ <u>15,476.00</u>	<u>[Increase] [Decrease]</u> of this Change Order: <u>No Change</u> Substantial Completion: _____ Ready for Final Payment: _____ days or dates
Contract Price incorporating this Change Order: \$ <u>9,562,793.00</u>	Contract Times with all approved Change Orders: Substantial Completion: <u>July 31, 2018</u> Ready for Final Payment: <u>November 30, 2018</u> days or dates

RECOMMENDED: By: <u>[Signature]</u> Title: <u>Project Manager - HDR</u> Date: _____	ACCEPTED: By: <u>[Signature]</u> Title: <u>City Manager</u> Date: <u>4/4/18</u>	ACCEPTED: By: <u>[Signature]</u> Title: <u>Vice-President</u> Date: <u>3-14-18</u>
--	--	---

Approved by Funding Agency (if applicable)

By: [Signature] Date: 4/4/18
 Title: RD STATE ARCHITECT

Superior Plumbing and Heating, Inc.
8861 Elim Street
Anchorage, AK 99507

Phone: 349-6572
Fax: 349-7091

Change Order Proposal

Job Name: Palmer Wastewater Treatment Facility Improvements

Job No: 02-21807

Superior Change Order Proposal #: 3

Owner's Change Order Proposal #: 0

To: Roger Hickel Contracting, Inc.
11001 Calaska Circle
Anchorage, AK 99507

Attn: Scott Dunlap

Date: 11/13/2017

In accordance with the terms of our subcontract / purchase order for the above project, we are proposing the following change. All exclusions of the original subcontract / purchase order, unless specifically stated otherwise, will remain the same:

Addition of Qty 14 4" and Qty 6 1" fabricated spools of SS Sch 10 pipe to offset owner furnished ALP risers around MBBR catwalk and up to SPH provided fab per Drawing 200D301 Key Note #3.

This price excludes field installation of fabricated piping that was already considered in original bid.

We will require an additional 0 days added to the contract completion date.

THE ABOVE WORK IS ACCOMPLISHED FOR THE SUM OF:

_____ \$ **15,476**

Please indicate acceptance of this change order proposal by signing below.

Roger Hickel Contracting, Inc.
Contractor

Accepted by: _____ Date: _____

Title: _____

This change order proposal is good for 30 days from the date issued.



Estimate Summary

Job Name: PALMER WWTF Upgrades
Estimator: Aaron Briggs
Date: 11/13/2017

Change Request Number: 3

Direct Costs

<u>Item/Description</u>	<u>Qty</u>	<u>Price Each</u>	<u>Material</u>	<u>Labor Hours</u>	<u>Burdened Wage Per Hour</u>	<u>Labor Cost</u>	<u>Notes</u>
Superintendent		\$	-		\$ 90.89	\$ -	
Working Foreman		\$	-	123	\$ 74.61	\$ 9,153.15	
Journeyman		\$	-	40	\$ 68.88	\$ 2,755.20	
Superintendent (Overtime)		\$	-		\$ 106.87	\$ -	
Working Foreman (Overtime)		\$	-	0	\$ 99.51	\$ -	
Journeyman (Overtime)		\$	-	0	\$ 92.09	\$ -	
Commissioning testing	0%	\$	-		\$ 80.06	\$ -	
Warranty	0%	\$	-		\$ 80.06	\$ -	
Project Management	Incl.	\$	-		\$ 105.30	\$ -	
Material & Tools		LS	\$ 2,808.00				
Credit:							
Subtotal:			\$ 2,808.00			\$ 11,908.35	
Estimating	2%	\$	294				
Small Tools	0.0%	\$	-				
Safety	0%	\$	-				
QA/QC	0%	\$	-				
Total Direct Cost :			\$ 3,102			\$11,908	

Subcontractors

<u>Item/Description</u>	<u>Quote Total</u>	<u>Notes</u>
Design / Engineering	\$ -	
Seismic Engineering / Shop Drawings	\$ -	
Mechanical Service Work	\$ -	
Pipe & Duct Insulation	\$ -	
Controls	\$ -	
Air & Water Balancing	\$ -	
Electrical Wiring	\$ -	
Total Subcontractor Costs :	\$ -	

Mechanical Summary

Direct Costs	\$ 3,102
Subcontractor Costs	\$ -
Subtotal Subcontractor & Direct Costs	\$ 3,102
Labor	\$ 11,908
Overhead 10%	\$ 310
Profit 5%	\$ 155
P&P Bond Fee (%):	\$ -
Total This Estimate:	\$ 15,476

REF: Palmer WWTP
DESCRIPTION: SST - Work ACTIVITY METHOD
BY: _____ DATE: _____
REMARKS: _____ SHT: _____

1

4"

CUT = 6 x .32 = 1.92
BEVEL = 6 x .22 = 1.32
45° = 2 x .08 = .16
FLANGE = 1 x .29 = .29
PIPE = 6 x .208 = 1.308
BUTTWELD = 5 x 3.06 = 15.30
20.298

FAB SHOP = x .65
13.19 EA.

OR

x .50 = 10.15 EA.
x 14

TOTAL HRS 4" = 142.15

1"

CUT = 6 x .14 = .84
BEVEL = 6 x .10 = .60
45° = 2 x .05 = .10
FLANGE = 1 x .07 = .07
PIPE = 6' x .074 = .444
BUTTWELD = 5 x .96 = 4.80

6.85

FAB SHOP = x .65
4.45 EA.

OR

x .50 = 3.43 EA.
x 6

20.58 TOTAL HRS 1"

- NOTE:**
1. MAINTAIN 4' CLEARANCE FOR CENTER LENGTH OF WALKWAY.
 2. COVER AND ACCESS HATCH LOCATIONS ARE SHOWN ON STRUCTURAL DRAWINGS.
 3. ORIENT FLOW METERS AND OTHER INSTRUMENTATION OUT OF WALKWAY.
 4. MAINTAIN 2' CLEARANCE BETWEEN GATE VALVE HANDLES AND AIRLINE PIPING.

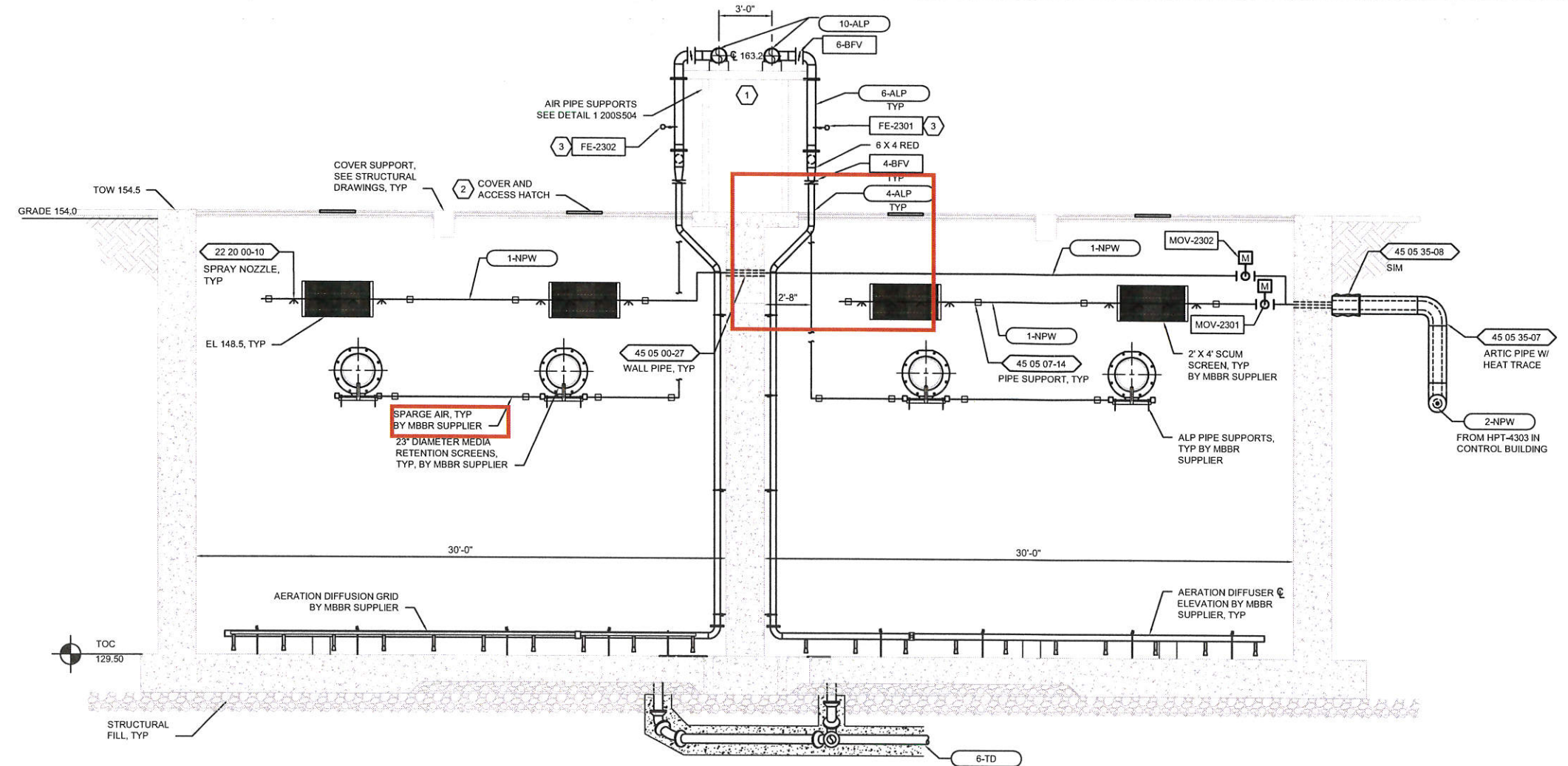

D SECTION
2000101 1/4"=1'-0"

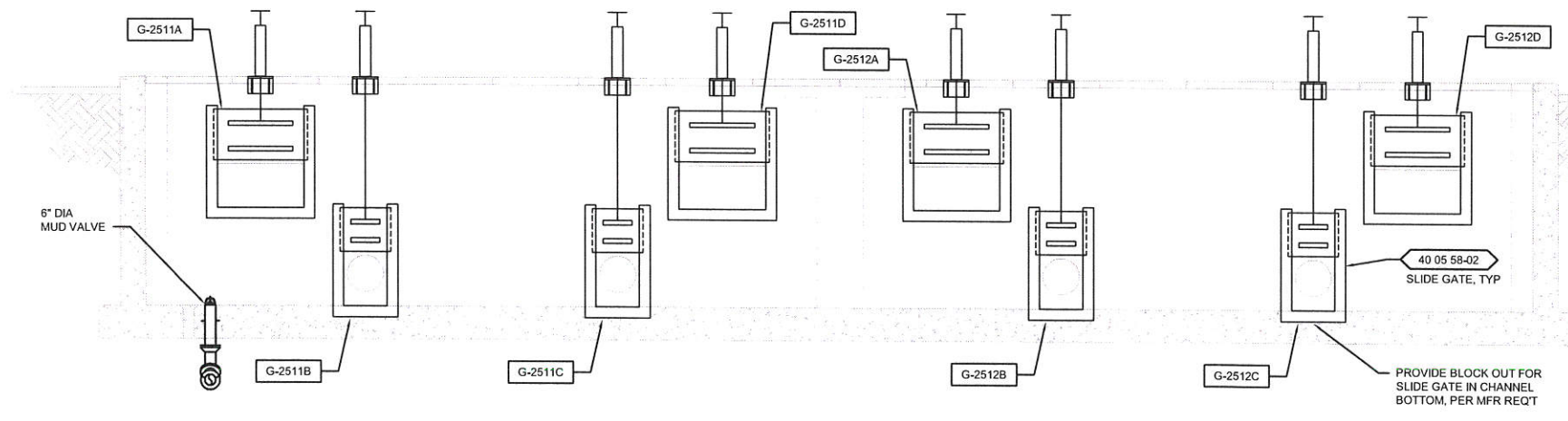

E SECTION
2000101 1/4"=1'-0"



ISSUE	DATE	DESCRIPTION
A	02/14/2017	ISSUE FOR BID

PROJECT MANAGER	J. RYAN MOYERS
CIVIL	R. MOYERS
STRUCTURAL	J. HERMON
ARCHITECTURAL	M. LAMBERT
PROCESS	J. WODRICH
MECHANICAL	T. CARSON
ELECTRICAL	B. McDONALD
INSTRUMENTATION	D. BEST
PROJECT NUMBER	200435 -...0249258

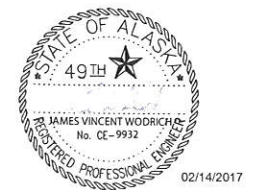

City of Palmer
WWTF
Improvements Project



**MBBR
PROCESS
SECTIONS - III**

FILENAME | 200D303.dwg
SCALE | AS NOTED

SHEET
200D303

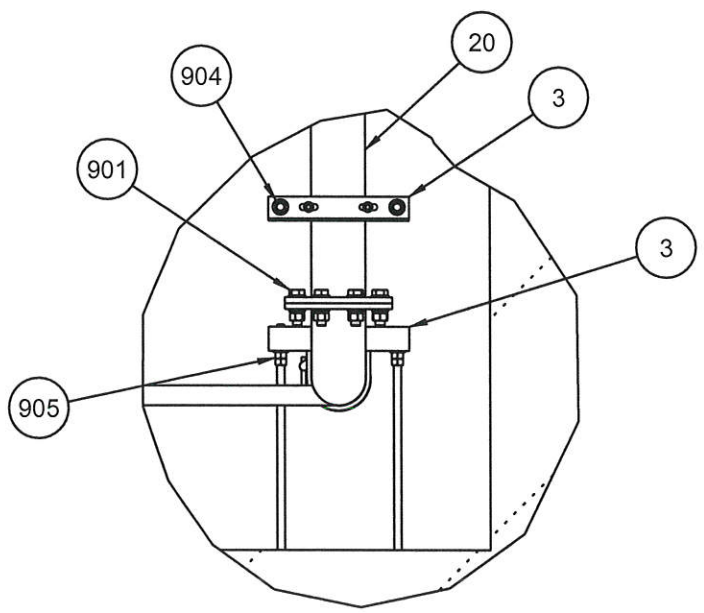
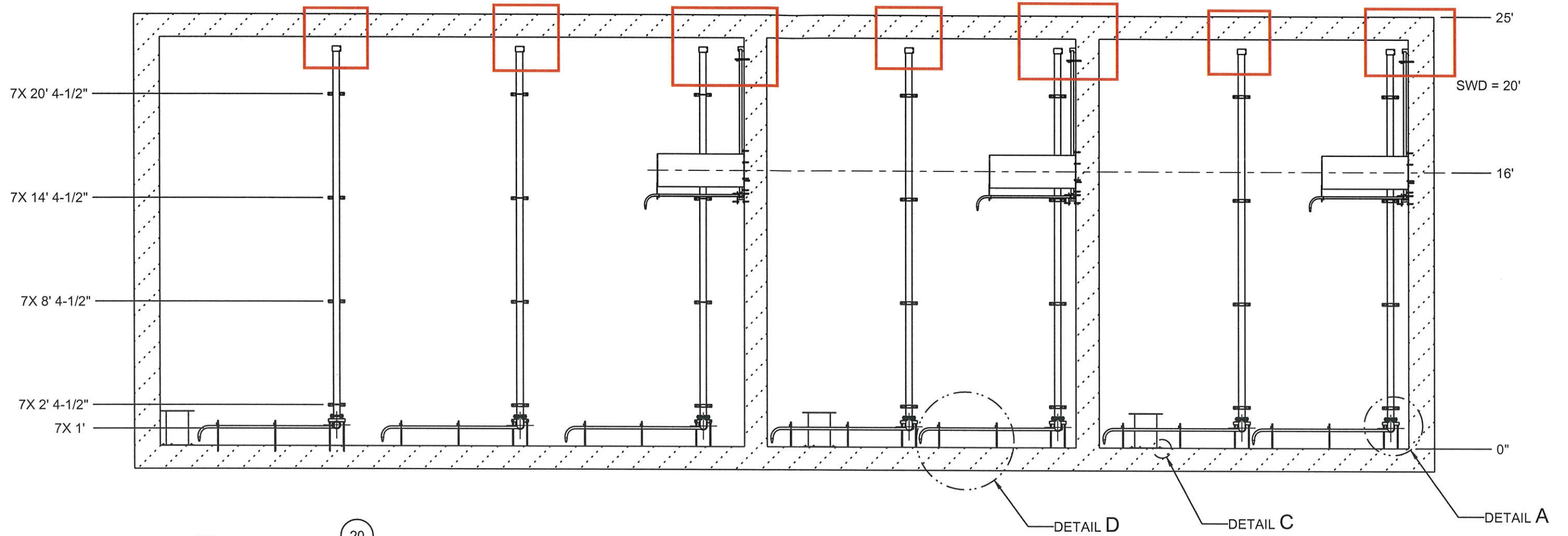

DETAIL A
SCALE 1:16

SECTION A-A

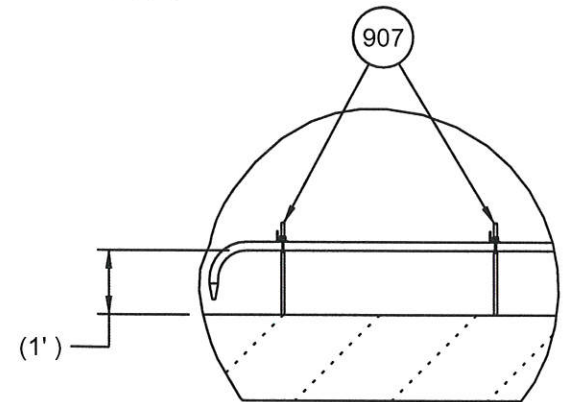

DIFFUSER SUPPORT ANCHOR
DETAIL D
SCALE 1:36

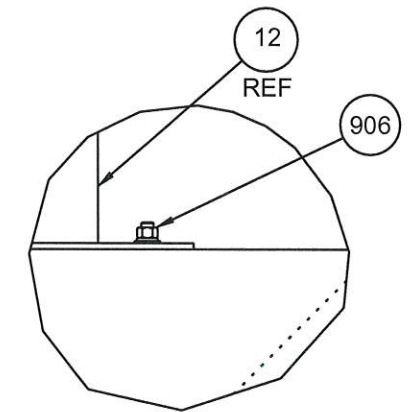

MUD VALVE SCREEN ATTACHMENT
DETAIL C
SCALE 1:8

ALL INFORMATION CONTAINED ON THIS DOCUMENT IS THE PROPERTY OF KRUGER AND/OR ITS AFFILIATES. THE DESIGN CONCEPTS AND INFORMATION CONTAINED HEREIN ARE PROPRIETARY TO KRUGER AND ARE SUBMITTED IN CONFIDENCE. THEY ARE NOT TRANSFERABLE AND MUST BE USED ONLY FOR THE PURPOSE FOR WHICH THE DOCUMENT IS EXPRESSLY SUBMITTED. THEY MUST NOT BE DISCLOSED, REPRODUCED, LOANED OR USED IN ANY OTHER MANNER WITHOUT THE EXPRESS WRITTEN CONSENT OF KRUGER. KRUGER ASSUMES NO RESPONSIBILITY OR LIABILITY FOR THE USE OF THIS DOCUMENT OR THE DESIGN CONCEPTS AND INFORMATION CONTAINED HEREIN FOR ANOTHER PROJECT OR IN A MANNER THAT DOES NOT RELATE TO THE FITNESS OR PURPOSE OF THIS DOCUMENT. IN NO EVENT SHALL THIS DOCUMENT OR THE DESIGN CONCEPTS AND INFORMATION CONTAINED HEREIN BE USED IN ANY MANNER DETRIMENTAL TO THE INTEREST OF KRUGER. ALL PATENT RIGHTS ARE RESERVED. ACCEPTANCE OF THE DELIVERY OF THIS DOCUMENT CONSTITUTES AGREEMENT TO THESE TERMS AND CONDITIONS.



5700202602
PALMER, AK

ANOXKALDNES
MECHANICAL, PLAN AND SECTIONS

SCALE 1:72	DRAWING NO 1708083	SHEET 8 of 11	REV 2
---------------	-----------------------	------------------	----------

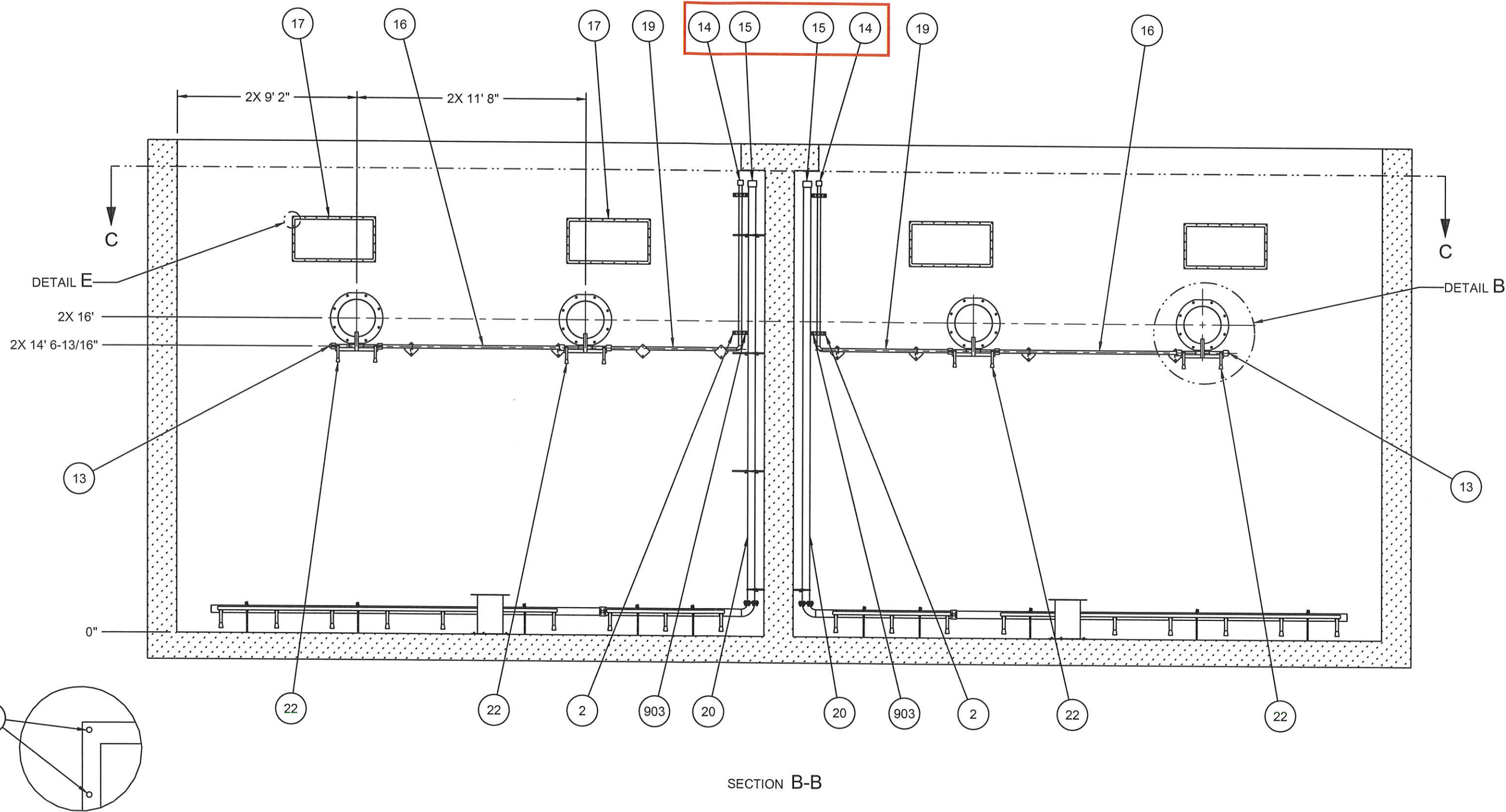

SECTION B-B

DETAIL E
SPIKE ANCHOR ATTACHMENT
SCALE 1:8

ALL INFORMATION CONTAINED ON THIS DOCUMENT IS THE PROPERTY OF KRUGER AND/OR ITS AFFILIATES. THE DESIGN CONCEPTS AND INFORMATION CONTAINED HEREIN ARE PROPRIETARY TO KRUGER AND ARE SUBMITTED IN CONFIDENCE. THEY ARE NOT TRANSFERABLE AND MUST BE USED ONLY FOR THE PURPOSE FOR WHICH THE DOCUMENT IS EXPRESSLY SUBMITTED. THEY MUST NOT BE DISCLOSED, REPRODUCED, LOANED OR USED IN ANY OTHER MANNER WITHOUT THE EXPRESS WRITTEN CONSENT OF KRUGER. KRUGER ASSUMES NO RESPONSIBILITY OR LIABILITY FOR THE USE OF THIS DOCUMENT OR THE DESIGN CONCEPTS AND INFORMATION CONTAINED HEREIN FOR ANOTHER PROJECT OR IN A MANNER THAT DOES NOT RELATE TO THE FITNESS OR PURPOSE OF THIS DOCUMENT. IN NO EVENT SHALL THIS DOCUMENT OR THE DESIGN CONCEPTS AND INFORMATION CONTAINED HEREIN BE USED IN ANY MANNER DETRIMENTAL TO THE INTEREST OF KRUGER. ALL PATENT RIGHTS ARE RESERVED ACCEPTANCE OF THE DELIVERY OF THIS DOCUMENT CONSTITUTES AGREEMENT TO THESE TERMS AND CONDITIONS.



ANOXKALDNES
MECHANICAL, PLAN AND SECTIONS

5700202602 PALMER, AK	SCALE 1:60	DRAWING NO 1708083	SHEET 9 of 11	REV 2
--------------------------	---------------	-----------------------	------------------	----------

**City of Palmer
Action Memorandum No. 18-055**

Subject: Accepting Commission Member Douglas Cruthers' Resignation from the Planning and Zoning Commission

Agenda of: May 1, 2018

Council Action: **Approved** **Amended:** _____
 Defeated

Originator Information:

Originator: Mayor DeVries via City Clerk

Department Review:

Route to:	Department Director:	Signature:	Date:
_____	Community Development	_____	_____
_____	Finance	_____	_____
_____	Fire	_____	_____
_____	Police	_____	_____
_____	Public Works	_____	_____

Approved for Presentation By:

	Signature:	Remarks:
City Manager	_____	_____
City Attorney	_____	_____
City Clerk	_____	_____

Certification of Funds:

Total amount of funds listed in this legislation: \$ 0.00

This legislation (√):

- Creates revenue in the amount of: \$ _____
- Creates expenditure in the amount of: \$ _____
- Creates a saving in the amount of: \$ _____
- Has no fiscal impact

Funds are (√):

- Budgeted Line item(s): _____
- Not budgeted _____

Director of Finance Signature: _____

Attachment(s):

- None

Summary Statement/Background:

Palmer Charter Chapter II Section 2.9 requires the City Council to approve resignations by members of boards and commissions.

Douglas Cruthers has submitted his resignation effective April 20, 2018.

The Clerk's Office will begin the advertising process to fill the vacancy created by the resignation and will forward applications to the Mayor for nomination and to the council for confirmation.

**City of Palmer
Action Memorandum No. 18-056**

Subject: Approving the Cancellation of the May 8, 2018, Regular Council Meeting

Agenda of: May 1, 2018

Council Action: **Approved** **Amended:** _____
 Defeated

Originator Information:

Originator: Mayor DeVries via City Clerk

Department Review:

Route to:	Department Director:	Signature:	Date:
_____	Community Development	_____	_____
_____	Finance	_____	_____
_____	Fire	_____	_____
_____	Police	_____	_____
_____	Public Works	_____	_____

Approved for Presentation By:

	Signature:	Remarks:
City Manager	_____	_____
City Attorney	_____	_____
City Clerk	_____	_____

Certification of Funds:

Total amount of funds listed in this legislation: \$ (300.00)

This legislation (√):

- Creates revenue in the amount of: \$ _____
- Creates expenditure in the amount of: \$ _____
- Creates a saving in the amount of: \$ 300.00
- Has no fiscal impact

Funds are (√):

- Budgeted Line item(s): _____
- Not budgeted _____

Director of Finance Signature: _____

Attachment(s):

- None

Summary Statement/Background:

Palmer High School Graduation is May 8, 2018. In support of our community and City Council to attend the graduation without a meeting conflict, cancelling the May 8, 2018, City Council Meeting is being considered. Palmer Municipal Code 2.04.080 states "A regular meeting may be canceled by the council...".

Is it the wish of the City Council to hold or cancel the May 8, 2018, Regular Council Meeting?

A. CALL TO ORDER

A special meeting of the Palmer City Council was held on November 28, 2017, at 6:00 p.m. in the Council Chambers, Palmer, Alaska.

Mayor DeVries called the meeting to order at 6:00 p.m.

B. ROLL CALL

Comprising a quorum of the Council, the following were present:

Edna DeVries, Mayor	Richard Best, Deputy Mayor
Steve Carrington	David Fuller
Sabrena Combs	Brad Hanson
Pete LaFrance	

Also in attendance were the following:

Nathan Wallace, City Manager	Norma I. Alley, MMC, City Clerk
Michael Gatti, City Attorney	

C. PLEDGE OF ALLEGIANCE

The Pledge of Allegiance was performed.

D. APPROVAL OF AGENDA

Mayor DeVries called for approval of the agenda.

Main Motion: To Approve the Agenda

Moved by:	Best
Seconded by:	Fuller
Action:	Motion Carried
In favor:	Best, Carrington, Combs, DeVries, Fuller, Hanson, LaFrance
Opposed:	None

E. AUDIENCE PARTICIPATION

None

F. COMMITTEE OF THE WHOLE

1. 2018 City of Palmer Budget
2. 2018 City of Palmer Pay Plan
3. 2018 City of Palmer Fee Schedule
4. 2018 City of Palmer Fine Schedule
5. 2018 City of Palmer Capital Improvement Program

Mayor DeVries called for a motion to enter into the Committee of the Whole.

Main Motion: To Enter Into a Committee of the Whole

Moved by:	Combs
Seconded by:	Fuller
Action:	Motion Carried
In favor:	Best, Carrington, Combs, DeVries, Fuller, Hanson, LaFrance
Opposed:	None

The Council entered into a Committee of the Whole at 6:02 p.m.

Topics addressed in the Committee of the Whole included a review on the Fee and Fine Schedule.

The Council adjourned from Committee of the Whole at 6:23 p.m. and reconvened the Special Meeting.

G. Public Hearing

1. **Resolution No. 18-001:** Adopting a Budget for the City of Palmer, Alaska for the Fiscal Year Beginning January 1, 2018, and Ending December 31, 2018, and Appropriating Monies (2nd Public Hearing)

Mayor DeVries opened the public hearing on Resolution No. 18-001. Seeing no one come forward to speak and hearing no objection from the City Council, the public hearing was closed.

Main Motion: To Adopt Resolution No. 18-001

Moved by:	Best
Seconded by:	Combs
Action:	
In favor:	
Opposed:	

Primary Amendment #1: To Amend the Budget to Reflect Deductions in Health Care Premiums by Reducing General Fund Department Line Items 6012 by \$134,232.00, Water/Sewer Fund 02-01-10-6012 by \$12,001.00, Airport Fund 03-01-10-6012 by \$2,209.00, and Solid Waste Fund 05-01-10-6012 by \$2,209.00; Increase MTA Event Center Revenue Fund 01-00-00-3005 by \$15,000.00; and Increase General Fund Revenue by \$75,000.00 for a Mat-Su Health Foundation Grant

Moved by:	Hanson
Seconded by:	Best
Action:	Motion Carried
In favor:	Best, Carrington, Combs, DeVries, Fuller, Hanson, LaFrance
Opposed:	None

Primary Amendment #2: To Create a New CIP Line Item in 08-01-10 for Public Security Cameras, Reallocate \$25,000.00 from CIP Museum/VIC Improvements Fund 08-01-10-7165, and Reallocate \$50,000.00 from CIP Downtown Masterplan Fund 08-01-10-7150 to the New Public Security Camera Fund 08-01-10

Moved by:	Hanson
Seconded by:	Best
Action:	Motion Carried
In favor:	Best, Carrington, Combs, DeVries, Fuller, Hanson, LaFrance
Opposed:	None

Discussion commenced on protecting citizens and providing safety in our community, ensuring citizens rights are not impeded, and a judicious process be adhered during creation of a policy and installation.

Primary Amendment #3: To Eliminate the Fire Department Life Safety Inspector Position from the Budget and Pay Plan

Moved by:	Hanson
Seconded by:	Best
Action:	Motion Carried
In favor:	Best, Carrington, Combs, DeVries, Hanson, LaFrance
Opposed:	Fuller

Primary Amendment #4: To Adopt the CIP, as Presented by the City Manager and as Amended by Primary Amendment #2, Striking the Public Works Vehicle Lift, Large Snow Blower, Water/Sewer Lift Station and Well Pumps, and Water/Sewer Truck

Moved by:	Hanson
Seconded by:	Best
Action:	Motion Carried
In favor:	Best, Carrington, Combs, DeVries, Fuller, Hanson, LaFrance
Opposed:	None

Primary Amendment #5: To Add \$350,000.00 to Street Improvements/Paving Fund 10-01-06-6301 with the Intent to Include Collector Trail Connector

Moved by:	Hanson
Seconded by:	LaFrance
Action:	Motion Carried
In favor:	Best, Carrington, Combs, DeVries, Fuller, Hanson, LaFrance
Opposed:	None

Primary Amendment #6: To Eliminate the Public Works Wastewater Administrative Assistant Position from the Budget and Pay Plan

Moved by:	Carrington
Seconded by:	Best
Action:	Motion Carried
In favor:	Best, Carrington, DeVries, Hanson, LaFrance
Opposed:	Combs, Fuller

Primary Amendment #7: To Create a New Line Item in the Council/Clerk Budget of 01-02-10, Move \$2,500.00 from the Wellness Program Fund 01-01-05-6065 to the New Line Item 01-02-10 with Intent for a Neighborhood Watch Program, and Calling It Council Community Watch Program

Moved by:	Hanson
Seconded by:	Best
Action:	Motion Carried
In favor:	Best, Carrington, Combs, DeVries, Fuller, Hanson, LaFrance
Opposed:	None

Primary Amendment #8: To Move \$81,739.00 from Local Improvement District Projects Funding to Fund Paving

Moved by:	Hanson
Seconded by:	LaFrance
Action:	Motion Carried
In favor:	Best, Carrington, Combs, DeVries, Fuller, Hanson, LaFrance
Opposed:	None

Primary Amendment #9: To Move \$2,500.00 From Wellness Program Fund 01-01-05-6065 to Christmas Decorations Fund 01-17-40-6075

Moved by:	LaFrance
Seconded by:	Combs
Action:	Motion Carried
In favor:	Best, Carrington, Combs, DeVries, Fuller, Hanson, LaFrance
Opposed:	None

Primary Amendment #10: To Reallocate Airport Fund 30 from Repavement Match to Purchase a Snow Blower and Runway Markings, Transfer \$10,750.00 from General Fund to Airport Fund 30 for the Purchase of a Snow Blower, and Allocate \$155,000.00 from Water Sewer Fund 02 to Water Sewer Capital Fund 24 for Equipment

Moved by:	Hanson
Seconded by:	Best
Action:	Motion Carried
In favor:	Best, Carrington, Combs, DeVries, Fuller, Hanson, LaFrance
Opposed:	None

Main Motion: To Direct the City Manager to Pursue Installation of a Bike Trail Along the Airport and Connect to the Springer System

Moved by:	DeVries
Seconded by:	Best
Action:	Motion Carried
In favor:	Best, Carrington, Combs, DeVries, Fuller, Hanson, LaFrance
Opposed:	None

Main Motion: To Direct the Parks, Recreation, and Cultural Resources Advisory Board to Pursue a Project Focused on Honoring Veterans and Incorporate a Large American Flag in that Project

Moved by:	DeVries
Seconded by:	Best
Action:	Motion Carried
In favor:	Best, Carrington, Combs, DeVries, Fuller, Hanson, LaFrance
Opposed:	None

Main Motion: To Direct the Parks, Recreation, and Cultural Resources Advisory Board to Pursue Neighborhood Parks for the Brittney Estates, Hidden Ranch, and Cedar Hills Neighborhoods

Moved by:	DeVries
Seconded by:	Hanson
Action:	Motion Carried
In favor:	Best, Carrington, Combs, DeVries, Fuller, Hanson, LaFrance
Opposed:	None

2. **Resolution No. 18-002:** Adopting the 2018 City of Palmer Employee Pay Plan (2nd Public Hearing)
3. **Resolution No. 18-003:** Adopting the 2018 Fee Schedule for the City of Palmer for the Fiscal Year Beginning January 1, 2018, and Ending December 31, 2018 (2nd Public Hearing)
4. **Resolution No. 18-004:** Adopting the 2018 Fine Schedule for the City of Palmer for the Fiscal Year Beginning January 1, 2018, and Ending December 31, 2018 (2nd Public Hearing)

Council Member Hanson requested to combine the public hearings for Resolution No. 18-002, Resolution No. 18-003, and Resolution No. 18-004. Hearing no objection from the City Council, Mayor DeVries opened the public hearing on Resolution No. 18-002, Resolution No. 18-003, and Resolution No. 18-004.

Mr. Carl Eugene Haberman spoke on the public hearing process, the time for the public to speak be increased when combining agenda items, holding meetings the same night as the Borough, and having to go through the public records request process in order to obtain meeting audio recordings.

Seeing no one further come forward to speak and hearing no objection from the Council, the public hearing was closed.

5. **Resolution No. 18-005:** Adopting the Five-Year Capital Improvement Program for the Fiscal Year Beginning January 1, 2018, and Ending December 31, 2018 (2nd Public Hearing)

Mayor DeVries opened the public hearing on Resolution No. 18-005.

Mr. Eugene Carl Habermann commented the public is not hearing the audio of special meetings and is not given opportunity to hear the decisions of the City Council.

Seeing no one further come forward to speak and hearing no objection from the City Council, the public hearing was closed.

Main Motion: To Direct Staff to Reflect the Amendments Approved for Resolution No. 18-001 in Resolution No. 18-005

Moved by:	Best
Seconded by:	Combs
Action:	Motion Carried
In favor:	Best, Carrington, Combs, DeVries, Fuller, Hanson, LaFrance
Opposed:	None

H. Record of Items Placed on the Table

City Clerk Norma Alley reported the following documents were Items Placed on the Table:

- Palmer Depot Use Graph;
- Paving Project Budget Estimate;
- Palmer Municipal Golf Course Equipment Budget Wishlist; and
- Proposal for Video Cameras.

I. COUNCIL COMMENTS

Council Members Carrington and Combs announced they would be gone next meeting and would be available by teleconference.

J. ADJOURNMENT

With no further business before the Council, the meeting adjourned at 8:45 p.m.

Approved this ____ day of _____, 2018.

Norma I. Alley, MMC, City Clerk

Edna B. DeVries, Mayor



PROCLAMATION

PROCLAIMING MAY 2018 AS PALMER BIKE MONTH

WHEREAS, the bicycle is a healthy, convenient, financially and environmentally sound form of transportation and an excellent tool for recreation and enjoyment of the City of Palmer's scenic beauty, local attractions, and friendly neighborhoods; and

WHEREAS, throughout the month of May, the residents of Palmer and its visitors will experience the joys of bicycling through commuting events, Bike to School Day, trail work days, or by simply getting out and going for a ride; and

WHEREAS, the City of Palmer's road and trail system attracts bicyclists each year, providing economic health, transportation, tourism, and scenic benefits; and

WHEREAS, creating a bicycling-friendly community has been shown to improve citizens' health, well-being, and quality of life, growing the economy of Palmer, attracting tourism dollars, improving traffic safety, supporting student health and learning, and reducing pollution, congestion, and wear and tear on our streets and roads.

NOW, THEREFORE, IT IS PROCLAIMED by the Mayor and City Council of the City of Palmer, Alaska, do hereby recognize May, 2018, as Palmer Bike Month, and encourage residents to bike to work, bike to school and bike for a healthy living.

IN WITNESS WHEREOF, I have hereunto set my hand and cause the seal of the City of Palmer to be affixed on this 24th day of April, 2018.

Edna B. DeVries, Mayor

Norma I. Alley, MMC, City Clerk



PROCLAMATION

A PROCLAMATION HONORING PALMER PARALYMPIC ATHLETES AND DECLARING APRIL 20, 2018, AS PALMER OLYMPIAN DAY IN THE CITY OF PALMER

WHEREAS, Palmer is home to dedicated Paralympic athletes Andrew Kurka and Grace Miller; and

WHEREAS, the City of Palmer is extremely proud of our local Paralympians; and

WHEREAS, Andrew and Grace embody the spirit of competitiveness, community, and resilience; and

WHEREAS, their contributions to their individual sports and to their community past, present and future warrant great appreciation and recognition; and

WHEREAS, their hard work and competitive drive resulted in selection to the 2018 United States Paralympic team and competition at the 2018 Paralympics which resulted in bringing home to the community a Gold and Silver Medal.

NOW, THEREFORE, IT IS PROCLAIMED by the Mayor and City Council of the city of Palmer, Alaska, that April 30, 2018, is Palmer Olympian Day in the City of Palmer and I call upon all citizens and civic organizations to join me in this special recognition of our Paralympians and their supporters. We offer our heartfelt congratulations on your selection and performance this year and the best of luck in your future endeavors.

IN WITNESS WHEREOF, I have hereunto set my hand and cause the seal of the city of Palmer to be affixed on this 18th day of April, 2018.

Edna B. DeVries, Mayor

Norma I. Alley, MMC, City Clerk



PROCLAMATION

PROCLAIMING MAY 2018 AS OLDER AMERICANS MONTH

WHEREAS, the City of Palmer includes older Americans who richly contribute to our community; and

WHEREAS, we acknowledge that what it means “to age” has changed—for the better; and

WHEREAS, the City of Palmer is committed to supporting older adults as they take charge of their health, explore new opportunities and activities, and focus on independence; and

WHEREAS, The citizens of Palmer can provide opportunities to enrich the lives of individuals of *all ages* by:

- involving older adults in the redefinition of aging in our community;
- promoting home- and community-based services that support independent living;
- encouraging older adults to speak up for themselves and others;
- providing opportunities for older adults to share their experiences; and

NOW, THEREFORE, IT IS PROCLAIMED by the Mayor and City Council of the city of Palmer, Alaska, do hereby recognize May, 2018, as Older Americans Month in Palmer, and encourage citizens to acknowledge older adults and the people who serve them as influential and vital parts of our community.

IN WITNESS WHEREOF, I have hereunto set my hand and cause the seal of the City of Palmer to be affixed on this 1st day of May, 2018.

Edna B. DeVries, Mayor

Norma I. Alley, MMC, City Clerk



PROCLAMATION

PROCLAIMING MAY 19, 2018, NATIONAL KIDS TO PARKS DAY

WHEREAS, May 19, 2018, is the eighth Kids to Parks Day organized and launched by the National Park Trust held annually on the third Saturday of May; and

WHEREAS, Kids to Parks Day empowers kids and encourages families to get outdoors and visit America's parks; and

WHEREAS, it is important to introduce a new generation to our nation's parks because of the decline in Park attendance over the last decades; and

WHEREAS, we should encourage children to lead a more active lifestyle to combat the issues of childhood illness and disease; and

WHEREAS, Kids to Parks Day is open to all children and adults across the country to encourage a large and diverse group of participants; and

WHEREAS, Kids to Parks Day will broaden children's appreciation for nature and the outdoors; and

WHEREAS, the City of Palmer is the home to numerous parks and recreational opportunities and is the gateway to many more that include biking, hiking, skiing, boating, baseball, soccer, skating, fishing, hunting and running, to name a few; and

NOW, THEREFORE, IT IS PROCLAIMED by the Mayor and City Council of the City of Palmer, Alaska, do hereby recognize May 19, 2018, as National Kids to Parks Day, and encourage residents to lead a more active lifestyle, enjoy the beauty and wonder of our community's outdoor opportunities, and take their kids to one of the City of Palmer's many parks.

IN WITNESS WHEREOF, I have hereunto set my hand and cause the seal of the City of Palmer to be affixed on this 1st day of May, 2018.

Edna B. DeVries, Mayor

Norma I. Alley, MMC, City Clerk



Norma I. Alley, MMC
City Clerk

Phone: (907) 745-3271
Direct: (907) 761-1321
Fax: (907) 745-0930

231 W. Evergreen Ave.
Palmer, Alaska 99645-6952
www.cityofpalmer.org

TO: Palmer City Council
FROM: Norma I. Alley, MMC *Norma I. Alley*
SUBJECT: City Clerk's Report for the May 1, 2018, Council Meeting

1. Boards & Commissions Attendance Spreadsheets

The monthly attendance spreadsheets are attached for:

- a. AAC (meeting was not held by the time the packet was published)
- b. BED
- c. PRCRAB
- d. P&ZC

2. Tentative Upcoming Meetings

Tentative Future Meeting Schedule			
Meeting Date	Meeting Type	Time	Notes
May 22	Regular	7 pm	
June 12	Regular	7 pm	
June 26	Regular	7 pm	
July 10	Special	6 pm	Mid-Year Budget Review
July 10	Regular	6 pm	
July 24	Special	6 pm	2019 Budget Planning Priorities
July 24	Regular	7 pm	
Aug 14	Regular	7 pm	
Aug 28	Regular	7 pm	

City of Palmer

Board of Economic Development Members

PMC 2.30.010.A. There is created a city board of economic development which shall consist of seven members.

Seat	Board Member	Term Expires
A	Barbara Hunt	Oct. 2020
D	Christopher Chappel	Oct. 2018
B	Peter Christopher	Oct. 2019
E	Janet Kincaid	Oct. 2019
C	Lorie Koppenberg	Oct. 2018
F	Kelly Turney	Oct. 2020
G	Dusty Silva	Oct. 2018
CC	Richard Best	Oct. 2018
PZC	Not Yet Appointed	Oct. 2018

PMC 2.30.140.B. Cause for removal. In addition, a board member may be removed by the council if, during any 12-month period while in office: 1) The board member is absent from three regular meetings without excuse; or 2) The board member is absent from six regular meetings.

2018 Attendance Record

Board Member	Jan	Feb	Mar	Mar **	Apr *	May	June	July	Aug	Sept	Oct *	Nov	Dec
Chappel	✓	✓	U	E									
Christopher	✓	✓	U	✓									
Hunt	✓	✓	✓	✓									
Kincaid	✓	E	✓	✓									
Koppenberg	✓	✓	✓	✓									
Turney	E	✓	✓	✓									
Silva	✓	✓	✓	✓									
Best	✓	✓	✓	✓									

2017 Attendance Record

Board Member	Jan	Feb	Mar	Mar **	Apr	May	June	July	Aug	Sept	Oct *	Nov	Dec *
Chappel	✓	✓	✓	✓	✓	✓	✓	E	✓	✓		✓	
Christopher	✓	✓	✓	E	✓	✓	E	E	✓	✓		U	
Hunt												✓	
Kincaid	✓	E	✓	✓	✓	✓	✓	✓	E	✓		✓	
Koppenberg	✓	✓	E	✓	✓	✓	E	✓	✓	E		✓	
Turney												✓	
Silva	✓	✓	✓	✓	✓	✓	✓	✓	✓	✓		✓	
Best												✓	

* Meeting Cancelled
 ** Special Meeting
 ✓ - Present

E - Excused Absence
 U - Unexcused Absence
 V - Vacant

City of Palmer

Parks, Recreation and Cultural Resources Advisory Board Members

PMC 2.22.010.A. There is created a city board for parks, recreation and cultural resources which shall consist of seven members.

Seat	Board Member	Term Expires
A	Stephanie Allen	Oct. 2020
B	Jo Ehmann	Oct. 2018
C	David Dodd	Oct. 2020
D	Shannon Connelly	Oct. 2019
E	Vacant	Oct. 2020
F	Meggie Aube-Trammell	Oct. 2018
G	Sally Pollen	Oct. 2019

PMC 2.22.140.B. Cause for removal. In addition, a board member may be removed by the council if, during any 12-month period while in office: 1) The board member is absent from three regular meetings without excuse; or 2) The board member is absent from six regular meetings.

2018 Attendance Record

Board Member	Jan	Feb	Feb **	Mar	Apr	May	June	July	July	Aug	Sept	Oct	Nov	Dec
Allen	✓	✓	✓	✓	✓									
Aube-Trammell	E	✓	✓	✓	✓									
Connelly	✓	✓	✓	✓	✓									
Dodd	E	✓	✓	E	E									
Ehmann	✓	✓	✓	U	✓									
Pollen	U	✓	✓	✓	✓									
Vacant														

2017 Attendance Record

Board Member	Jan	Feb	Mar	Mar **	Apr	May *	June	July	July **	Aug	Sept	Oct	Nov	Dec *
Allen	E	✓	✓	E	✓		✓	✓	✓	E	E	✓	✓	
Aube-Trammell	✓	✓	✓	✓	✓		✓	✓	✓	✓	✓	✓	✓	
Connelly	✓	✓	✓	✓	✓		✓	✓	✓	E	✓	✓	✓	
Dodd													✓	
Ehmann	✓	✓	✓	✓	✓		E	E	E	✓	✓	✓	✓	
Pollen													✓	

* Meeting Cancelled
 ** Special Meeting
 ✓ – Present
 E – Excused Absence
 U – Unexcused Absence
 V – Vacant

City of Palmer

Planning & Zoning Advisory Commission Members

PMC 2.20.010.A. There is created a city planning and zoning commission which shall consist of seven members who shall be nominated by the mayor and confirmed by the city council. All members must be residents of the city.

Seat	Commission Member	Term Expires
A	Gena Ornquist	Oct. 2020
B	Richard Benedetto	Oct. 2019
C	Merry Maxwell	Oct. 2018
D	Kristy Thom Bernier	Oct. 2019
E	Dan Lucas	Oct. 2020
F	David Petty	Oct. 2018
G	Douglas Cruthers	Oct. 2018

PMC 2.20.321.C. Cause for removal. In addition, a commissioner may be removed by the council if, during any 12-month period while in office: 1) The commissioner is absent from three regular meetings without excuse; or 2) The commissioner is absent from six regular meetings.

2018 Attendance Record

Commissioner	Jan	Feb	Mar *	Apr **	Apr	May	Jun	Jul	Aug	Sep	Oct	Nov	Dec *
Benedetto	E	✓		✓	✓								
Cruthers	✓	✓		U	U								
Lucas	✓	✓		✓	✓								
Maxwell	✓	✓		E	U								
Ornquist	✓	✓		E	E								
Petty	✓	✓		✓	✓								
Thom Bernier	✓	✓		✓	✓								

2017 Attendance Record

Commissioner	Jan	Feb	Mar	Apr **	Apr	May	Jun	Jul	Aug	Sep	Oct	Nov	Dec *
Benedetto												✓	
Cruthers	E	*	E	✓	✓	✓	✓	✓	U	✓	✓	✓	
Lucas	✓	*	✓	✓	✓	✓	✓	✓	✓	✓	✓	✓	
Maxwell	✓	*	✓	E	✓	E	✓	E	✓	✓	✓	E	
Ornquist	✓	*	✓	✓	✓	✓	✓	✓	✓	✓	E	✓	
Petty	✓	*	✓	✓	✓	✓	✓	✓	✓	✓	✓	✓	
Thom Bernier	✓	*	✓	✓	E	✓	E	✓	✓	E	✓	✓	

* Meeting Cancelled
 ** Special Meeting
 ✓ – Present

E – Excused Absence
 U – Unexcused Absence
 V – Vacant

**City of Palmer
Ordinance No. 18-003**

Subject: Amending the Palmer Municipal Code Title 18 Pertaining to Absentee Voting by Electronic Transmission

Agenda of: April 24, 2018 – Introduction
May 1, 2018 – Public Hearing

Council Action: **Adopted** **Amended:** _____
 Defeated



Originator Information:

Originator: Norma I. Alley, City Clerk

Department Review:

Route to:	Department Director:	Signature:	Date:
_____	Community Development	_____	_____
_____	Finance	_____	_____
_____	Fire	_____	_____
_____	Police	_____	_____
_____	Public Works	_____	_____

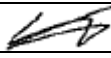
Approved for Presentation By:

	Signature:	Remarks:
City Manager		_____
City Attorney		_____
City Clerk		_____

Certification of Funds:

Total amount of funds listed in this legislation: \$ 0.00

This legislation (√):

- Creates revenue in the amount of: \$ _____
- Creates expenditure in the amount of: \$ _____
- Creates a saving in the amount of: \$ _____
- Has no fiscal impact

Funds are (√):

- Budgeted Line item(s): _____
- Not budgeted

Director of Finance Signature: 

Attachment(s):

- Ordinance No. 18-003

Summary Statement/Background:

In 2011 the City Council adopted Ordinance No. 11-002, which enacted absentee voting by electronic transmission. After six years in practice, there have been a total of 10 electronic transmission ballots cast as shown in the table below.

Year	Number of Electronic Means Ballots Casted	Total Number of Absentee Ballots Casted
2017	6	10
2016	1	2
2015	0	0
2014	1	7
2013	2	3
2012	0	1
Totals:	10	23

A recent election security examination was conducted by the Center for American Progress. In this examination, cybersecurity standards were one focus and the state of Alaska was dinged for allowing voters to return ballots electronically or by fax. The report stated that Alaska should prohibit voters from returning voted ballots electronically and recommendation was given that all voted ballots be returned by mail or delivered in person. The state of Alaska Division of Election has suspended the return of ballots through electronic means (web portal).

Ballots casted by electronic means is a vulnerability in the system. After discussions with the 2017 Canvass Board regarding the city process of absentee voting by electronic transmission, recent national cybersecurity concerns, and the lack of ensuring ballot anonymity, it is recommended the Palmer Municipal Code Title 18 be amended by repealing absentee voting by electronic transmission.

Administration's Recommendation:

Adopt Ordinance No. 18-003 Amending the Palmer Municipal Code Title 18 Pertaining to Absentee Voting by Electronic Transmission.

LEGISLATIVE HISTORY

Introduced by: Mayor via City Clerk
Date: April 24, 2018
Public Hearing: May 1, 2018
Action:
Vote:

Yes:	No:

CITY OF PALMER, ALASKA

Ordinance No. 18-003

An Ordinance of the Palmer City Council Amending the Palmer Municipal Code Title 18 Pertaining to Absentee Voting by Electronic Transmission

WHEREAS, City Council adopted Ordinance No. 11-002, which enacted absentee voting by electronic means, and;

WHEREAS, City Council adopted Ordinance No. 12-009, which moved absentee voting by electronic means from Chapter 18.25 to Chapter 18.27 and added 18.27.023(E), and;

WHEREAS, with current security and anonymity concerns with elections, it is prudent for the city of Palmer to repeal code language pertaining to absentee voting by electronic transmission to eliminate known vulnerabilities, ensure security of electorate’s ballots, and validity of our election process.

THE CITY OF PALMER, ALASKA, ORDAINS:

Section 1. Classification. This ordinance shall be permanent in nature and shall be incorporated into the Palmer Municipal Code.

Section 2. Severability. If any provisions of this ordinance or application thereof to any person or circumstances are held invalid, the remainder of this ordinance and the application to the other persons or circumstances shall not be affected thereby.

Section 3. Palmer Municipal Code Section 18.05.010 is hereby amended to read as follows (new language is underlined and deleted language is stricken):

18.05.010 Definitions.

“Regular ballot” means a ballot voted at the polls which is not a questioned, early-voter or an absentee by mail ~~or electronic transmission~~ ballot.

Section 4. Palmer Municipal Code Section 18.20.020(F) is hereby amended to read as follows (new language is underlined and deleted language is stricken):

18.20.020 Notice of election.

F. Instructions for absentee by mail, ~~absentee by electronic transmission~~, early and special needs voting; and

Section 5. Palmer Municipal Code Section 18.27.010(A) is hereby amended to read as follows (new language is underlined and deleted language is stricken):

18.27.010 Eligible persons – Liberal construction.

A. At any election, any registered qualified voter may for any reason vote an absentee by mail; ~~absentee by electronic means ballot or early ballot, if provided by the clerk.~~

Section 6. Palmer Municipal Code Section 18.27.030 is hereby repealed (new language is underlined and deleted language is stricken):

~~**18.27.030 Absentee voting – By electronic transmission.**~~

~~A. Ballot Application. A qualified voter may apply for an absentee ballot to be sent by electronic transmission. The request must be made not less than the day immediately preceding the election. Absentee ballots will be electronically transmitted to the location designated in the application. If no location is designated, and if the request is received no later than seven days prior to the election, the ballot will be mailed in the manner provided in PMC 18.27.020 for absentee ballots by mail. The clerk will provide reasonable conditions for electronically transmitting absentee ballots.~~

~~B. Electronic Transmission. A ballot electronically transmitted shall contain a copy of the ballot to be used at the election in a form suitable for transmission. A photocopy of the computerized ballot card to be used by persons voting in person at the polling places is acceptable.~~

~~C. Confidentiality Statement. An absentee ballot that is completed and returned by the voter by electronic transmission must:~~

- ~~1. Contain the following statement: "I understand that by using electronic transmission to return my marked ballot, I am voluntarily waiving a portion of my right to a secret ballot to the extent necessary to process my ballot, but expect that my vote will be held as confidential as possible," followed by the voter's signature and date of signature; and~~
- ~~2. Be accompanied by a statement executed under oath as to the voter's identity; the statement under oath must be witnessed by one United States citizen who is 18 years of age or older.~~

~~D. Ballot Return. The voter shall mark the ballot on or before the date of the election and shall return the ballot by:~~

- ~~1. Mail Service. An absentee ballot shall be mailed to the clerk not later than election day. The ballot shall not be counted unless it is received by the close of business on the third calendar day following the election; or~~
- ~~2. Electronic Transmission. A voter who returns the absentee ballot by electronic transmission must comply with the same deadlines for voting in person on or before the closing hour of the polls.~~

~~When a completed absentee ballot is received by electronic transmission, the clerk will note the date of receipt on the absentee ballot application log and, if the ballot is received on election day, the time of receipt. The clerk will then:~~

- ~~a. Remove the ballot portion of the transmission from the portion that identifies the voter;~~
- ~~b. Place the ballot portion in a secrecy sleeve;~~
- ~~c. Seal the secrecy sleeve in an outer envelope of the type used for absentee ballots returned by mail, and seal that envelope;~~
- ~~d. Attach the voter identification portion to the outer envelope; and~~
- ~~e. Forward the outer sealed envelope to the canvass board for review.~~

Section 7. Palmer Municipal Code Section 18.27.050(A) is hereby amended to read as follows (new language is underlined and deleted language is stricken):

18.27.050 Questioned voting.

A. A questioned voter is a person:

1. Whose name does not appear on the register in the precinct where the voter attempts to vote or on the official register at an early-voting location;
2. Who has received an absentee by mail ~~or by electronic transmission~~ ballot and does not turn it in when voting at the voter's precinct on election day;
3. Who does not bear identification or is not personally known to an election official though the voter's name appears on the precinct register; or
4. Who is questioned for good cause at the polls in writing pursuant to subsection (C) of this section.

Section 8. Palmer Municipal Code Section 18.35.080(A) is hereby amended, 18.35.080(C) is hereby repealed, and subsequent subsections relettered to read as follows (new language is underlined and deleted language is stricken):

18.35.080 Counting absentee by mail ~~and electronic transmission~~ ballots.

A. The absentee by mail ~~and electronic transmission~~ ballots shall be delivered to the canvass board for review.

~~C. Absentee Voting by Electronic Transmission. An electronically transmitted ballot shall be counted in the same manner as other absentee ballots, even though this procedure may reveal to one or more election officials the manner in which a particular absentee voter cast his or her ballot. However, it shall be unlawful to display an electronic ballot in a manner revealing the way in which a particular voter cast his or her ballot to any person other than the city clerk, a member of the clerk's staff, an election official in the course of his or her duties, or an attorney advising the clerk on legal questions concerning the ballot.~~

~~D.~~ E. If the voter is not qualified or the ballot has not been properly cast, the clerk shall notify the voter, in writing, of the reason the ballot was not counted.

~~E.~~ F. The rejected ballot shall be placed in a container which shall be labeled "no count ballots." The envelopes shall be retained with the other election records and destroyed as set out in PMC 18.35.120.

Section 9. Palmer Municipal Code Section 18.35.010(A) and (E) are hereby amended to read as follows (new language is underlined and deleted language is stricken):

18.35.100 Counting and canvass of returns, certificate of election.

A. Not later than the Monday following each election, the canvass board shall meet and shall:

1. In full view of those present, judge the validity of absentee by mail, ~~absentee by electronic transmission, early,~~ questioned and special needs ballots, open and tally accepted ballots, and compile the total votes cast in the election;

E. To certify the election results the council shall enter the determination in a resolution of the council along with the following information:

1. The total number of poll, early-voter, absentee by mail, ~~absentee by electronic transmission,~~ questioned, and special needs ballots cast in the election;

Section 10. Palmer Municipal Code Section 18.45.020(B) is hereby amended to read as follows (new language is underlined and deleted language is stricken):

18.45.020 Form of application.

B. The application shall include a deposit in cash, by certified check or by bond with a surety approved by the clerk.

1. The deposit amount, established in the current, adopted budget, shall be paid for each precinct.
2. If less than all precincts are requested for recount, early voter, absentee by mail, ~~absentee by electronic means~~ and questioned ballots shall be considered one combined precinct for the purposes of the recount.
3. If all precincts are included in the request, there shall be no additional charge for the recount of early voter, absentee by mail, ~~absentee by electronic means~~ and questioned ballots.

Section 11. Palmer Municipal Code Section 18.45.040(B) is hereby amended to read as follows (new language is underlined and deleted language is stricken):

18.45.040 Procedure for recount.

B. The canvass board shall:

1. Review all ballots to determine which ballots, or parts of ballots, were properly marked and which ballots are to be counted in the recount;
2. Check the accuracy of the original count and all documentation provided by the clerk and election officials;
3. Check the number of ballots issued and cast to the amount distributed:
 - a. At each precinct;
 - b. At each early voting location;
 - c. By absentee by mail ~~and absentee by electronic means~~.

Section 12. Effective Date. Ordinance No. 18-003 shall take effect upon adoption by the City of Palmer City Council.

Passed and approved this ____ day of ____, 2018.

Edna B. DeVries, Mayor

Norma I. Alley, MMC, City Clerk

**City of Palmer
Resolution No. 18-013**

Subject: Accepting and Appropriating the 2018 Volunteer Fire Assistance Grant From the State of Alaska, Department of Natural Resources, Division of Forestry in the Amount of \$7,500.00 for the Purchase of Wildland Fire Personal Protective Clothing and Wildland Firefighting Equipment

Agenda of: May 1, 2018

Council Action: **Approved** **Amended:** _____
 Defeated

Originator Information:

Originator: John McNutt, Fire Chief

Department Review:

Route to:	Department Director:	Signature:	Date:
_____	Community Development	_____	_____
<u> √ </u>	Finance	<u><i>[Signature]</i></u>	<u>04/16/2018</u>
_____	Fire	_____	_____
_____	Police	_____	_____
_____	Public Works	_____	_____

Approved for Presentation By:

	Signature:	Remarks:
City Manager	<u><i>[Signature]</i></u>	_____
City Attorney	<u><i>[Signature]</i></u>	_____
City Clerk	<u><i>[Signature]</i></u>	_____

Certification of Funds:

Total amount of funds listed in this legislation: \$ 7,500.00

This legislation (√):

- Creates revenue in the amount of: \$ 7,500.00
- Creates expenditure in the amount of: \$ _____
- Creates a saving in the amount of: \$ _____
- Has no fiscal impact

Funds are (√):

- Budgeted Line item(s): 01-00-00-3344 VFA – Fire Grant
- Not budgeted 01-13-10-6046 Small Tools & Equipment

Director of Finance Signature: *[Signature]*

Attachment(s):

- Resolution No. 18-013
- Grant Award Letter

Summary Statement/Background:

The City of Palmer has been granted a State of Alaska, Department of Natural Resources, Division of Forestry, Volunteer Fire Assistance Grant in the amount of \$7,500.00 to purchase wildland firefighter protective clothing and wildland firefighting equipment for Palmer Fire and Rescue.

Palmer Fire and Rescue applied for this grant in February 2018. This grant is used to assist in the purchase of wildland fire protection equipment for departments across Alaska. In March 2018 an interagency committee met to allocate the funds to area fire departments, and Palmer Fire and Rescue was chosen to receive \$7,500.00. This grant will be matched by Palmer Fire and Rescue budgeted funds in the amount of \$2,054.00.

The firefighting equipment that will be purchased is forestry firefighting safety packs. These safety packs will allow firefighters to stay efficient and effective, but most importantly safe, by allowing responders to carry the necessary safety shelters along with drinking water and other safety equipment when working for extended time periods on a wildland fire incident. The personal protective clothing will replace worn clothing that is not safe for responders to use in a wildland fire emergency response. This allows more responders to work safely when deployed on a large wildland fire emergency response.

Administration's Recommendation:

Approve Resolution No. 18-013 to accept and appropriate the 2018 Volunteer Fire Assistance Grant from the State of Alaska, Department of Natural Resources, Division of Forestry for the purchase of wildland firefighting equipment, fire safety shelters and wildland firefighting personal protective clothing.

LEGISLATIVE HISTORY

Introduced by: City Manager Wallace

Date:

Public Hearing:

Action:

Vote:

Yes:

No:

--	--

CITY OF PALMER, ALASKA

Resolution No. 18-013

A Resolution of the Palmer City Council Authorizing the City Manager to Accept and Appropriate the 2018 Volunteer Fire Assistance Grant and Authorizing the City Manager to Purchase Wildland Fire Personal Protective Clothing and Wildland Firefighting Equipment

WHEREAS, the City of Palmer Fire & Rescue provides fire protection and response to calls for service for the citizens of Palmer; and

WHEREAS, the City of Palmer Fire & Rescue needs wildland firefighter protective clothing for the responders' protection during the extinguishment of fire emergencies; and

WHEREAS, the City of Palmer Fire & Rescue needs dependable wildland firefighting equipment for the suppression of wildland fire emergencies; and

WHEREAS, the City of Palmer Fire & Rescue has been awarded \$7,500.00 from the State of Alaska, Department of Natural Resources, Volunteer Fire Assistance Grant for the purchase of wildland firefighting equipment and fire safety shelters.

NOW, THEREFORE, BE IT RESOLVED the Palmer City Council hereby accepts and appropriates \$7,500.00 from the Volunteer Fire Assistance Grant into Funds 01-00-00-3344 and 01-13-10-6046 and authorizes the City Manager to purchase wildland firefighting equipment and fire safety shelters.

Approved by the Palmer City Council this ____ day of _____, 2018.

Edna B. DeVries, Mayor

Norma I. Alley, MMC, City Clerk



THE STATE
of **ALASKA**
GOVERNOR BILL WALKER

Department of Natural Resources

DIVISION OF FORESTRY

550 West 7th Suite 1450

Anchorage, AK 99501

Main: 907.269-8463

Fax: 907.269-8421

March 28, 2018

Dear Volunteer Fire Department:

Thank you for applying for the 2018 Volunteer Fire Assistance grants. 41 fire departments applied for a Volunteer Fire Assistance (VFA) grant requesting a total of \$293,996.24 in assistance. 39 of the 41 applications will receive some level of funding. A total of \$277,123.43 will be awarded. The enclosed spreadsheet lists all applicants and amount requested. If a fire department was awarded a grant, the amount awarded will be listed in the column titled "Amount Awarded". Some VFDs will not receive an award this year and some will receive a partial award due to some requested items being ineligible for funding.

Successful applicants for VFA grants will soon receive their check from their local Forestry office.

- Checks must be cashed within 90 days of issuance. It is strongly advised checks be cashed upon receipt.
- To be eligible for the 2019 VFA grants, compliance documentation, such as copies of receipts for 2018 grant expenditures, must be submitted at the time of or prior to submitting a 2019 application to your nearest Forestry office.
- Volunteer Fire Assistance is an award of Federal Financial Assistance with funding from the USDA Forest Service and as such is subject to the Office of Management and Budget (OMB) Circular A-87, Cost Principles for State, Local and Indian Tribal Governments; OMB Circular A-102 (Grants and Cooperative Agreements with State and Local governments) as implemented by USDA regulation 7 CFR Part 3016 (Uniform Administrative Requirements for Grants and Cooperative Agreements to State and Local Governments); and OMB Circular A-133 (Audits of States, Local Governments, and Non-Profit Organizations) as implemented by USDA regulation 7 CFR 3052. The OMB Circulars are available on the internet at www.whitehouse.gov/omb/grants. Electronic copies of the CFR's can be obtained at the following internet site: www.gpoaccess.gov/cfr/. If you are unable to retrieve these regulations electronically, please contact Arlene Weber-Sword at (907)269-8471.

If an application was not fully successful do not be discouraged and continue to apply every year by submitting a complete online application package by deadline. VFDs that did not receive any funding or received a partial amount, please contact your local Forestry Fire Management Officer with any questions regarding the application. The local Division of Forestry offices will be sending out VFA award checks with a letter outlining compliance requirements sometime in the next few weeks.

Sincerely,

A handwritten signature in blue ink that reads "Arlene W. Sword".

Arlene Weber-Sword
Fire Staff Officer

2018 VFA Grant Awards

Fire Department	Amount Requested	Amount Awarded	Division of Forestry Office
Rural Deltana VFD	\$7,500.00	\$7,500.00	Delta Area Office
Chena-Goldstream Fire & Rescue	\$7,371.00	\$7,371.00	Fairbanks Area Office
Ester VFD	\$6,833.00	\$6,833.00	Fairbanks Area Office
Salcha Fire & Rescue	\$7,458.30	\$7,458.30	Fairbanks Area Office
Steese Area VFD	\$7,395.30	\$7,395.30	Fairbanks Area Office
Tri-Valley VFD	\$7,429.00	\$7,259.00	Fairbanks Area Office
Anchor Point Fire & Emergency Medical Service Area	\$7,500.00	\$7,500.00	Kenai Kodiak Area Office
Bear Creek Fire/EMS Department	\$7,437.60	\$7,437.60	Kenai Kodiak Area Office
Fire Protection Area No. 1 (Bayside Fire Station)	\$7,315.00	\$7,315.00	Kenai Kodiak Area Office
Kachemak Emerg. Services	\$7,461.00	\$7,461.00	Kenai Kodiak Area Office
Kenai FD	\$7,499.85	\$7,499.85	Kenai Kodiak Area Office
Lowell Point VFD	\$7,492.50	\$7,492.50	Kenai Kodiak Area Office
Nikiski FD	\$6,718.14	\$6,718.14	Kenai Kodiak Area Office
Ninilchik Emergency Services	\$5,395.50	\$5,395.50	Kenai Kodiak Area Office
Seward FD	\$7,312.50	\$7,312.50	Kenai Kodiak Area Office
Bethel FD	\$7,470.00	\$7,470.00	Mat Su Area and Southwest District
Butte FD	\$6,674.40	\$6,674.40	Mat Su Area and Southwest District
Caswell Lakes FSA #135	\$5,255.05	\$5,255.05	Mat Su Area and Southwest District
Chignik Lagoon VFD	\$7,500.00	\$6,780.00	Mat Su Area and Southwest District
Girdwood Vol. Fire & Rescue, Inc.	\$7,360.00	\$7,360.00	Mat Su Area and Southwest District
Houston FD	\$7,470.00	\$7,470.00	Mat Su Area and Southwest District
Nondalton VFD	\$7,500.00	\$7,500.00	Mat Su Area and Southwest District
Nunapitchuk FD	\$7,319.02	\$7,319.02	Mat Su Area and Southwest District
Palmer Fire and Rescue	\$7,500.00	\$7,500.00	Mat Su Area and Southwest District
Sutton VFD	\$7,442.50	\$7,442.50	Mat Su Area and Southwest District
Talkeetna VFD	\$7,499.85	\$7,499.85	Mat Su Area and Southwest District
West Lakes FD	\$7,500.00	\$7,500.00	Mat Su Area and Southwest District
Willow VFD	\$7,449.25	\$7,449.25	Mat Su Area and Southwest District
Craig VFD	\$7,500.00	\$7,500.00	Southeast Alaska
Gustavus VFD	\$7,312.50	\$7,312.50	Southeast Alaska
Haines VFD	\$7,500.00	\$7,500.00	Southeast Alaska
Tenakee Springs VFD	\$7,500.00	\$0.00	Southeast Alaska
Wrangell VFD	\$7,005.00	\$7,005.00	Southeast Alaska
Mentasta VFD	\$7,110.50	\$6,510.50	Tok Area Office
Northway VFD	\$7,497.02	\$7,211.02	Tok Area Office
Tetlin VFD	\$6,030.00	\$6,030.00	Tok Area Office
Tok VFD	\$5,842.79	\$5,842.79	Tok Area Office
Gakona VFD	\$6,921.86	\$6,921.86	Valdez-Copper River Area Office
Kennicott/McCarthy VFD	\$7,470.00	\$7,371.00	Valdez-Copper River Area Office
Kenny Lake VFD	\$7,497.81	\$0.00	Valdez-Copper River Area Office
Valdez FD	\$6,750.00	\$6,750.00	Valdez-Copper River Area Office
GRAND TOTAL	\$293,996.24	\$277,123.43	

**City of Palmer
Action Memorandum No. 18-057**

Subject: Approving an Exception to the City of Palmer Charter Section 2.3 Allowing Council Member Hanson to be Eligible for Employment for Which a Salary is Paid by the City Prior to One Year Elapsing Following His Term

Agenda of: May 1, 2018

Council Action: **Approved** **Amended:** _____
 Defeated

Originator Information:

Originator: Mayor DeVries

Department Review:

Route to:	Department Director:	Signature:	Date:
_____	Community Development	_____	_____
_____	Finance	_____	_____
_____	Fire	_____	_____
_____	Police	_____	_____
_____	Public Works	_____	_____

Approved for Presentation By:

	Signature:	Remarks:
City Manager	_____	_____
City Attorney	_____	_____
City Clerk	_____	_____

Certification of Funds:

Total amount of funds listed in this legislation: \$ _____

This legislation (√):

- Creates revenue in the amount of: \$ _____
- Creates expenditure in the amount of: \$ _____
- Creates a saving in the amount of: \$ _____
- Has no fiscal impact

Funds are (√):

- Budgeted Line item(s): _____
- Not budgeted _____

Director of Finance Signature: _____

Attachment(s):

- None

Summary Statement/Background:

Council Member Hanson applied for the position in the city administration of Community Development Director. He was selected as the most qualified candidate (of nine candidates) and offered the position pending his eligibility/availability to serve in the position.

The City of Palmer Charter Section 2.3 Persons ineligible for City office or employment states a council member shall not be eligible for appointment to an office or for employment for which a salary is paid by the city until one year has elapsed following the term for which he was elected or appointed. An exception may be made with the approval of five (5) or more members of the Council.

Administration's Recommendation:

To approve Action Memorandum No. 18-057 approving an exception to the City of Palmer Charter Section 2.3 to allow Council Member Hanson to be eligible for employment for which a salary is paid by the city prior to one year elapsing following his term

**City of Palmer
Information Memorandum No. 18-001**

Subject: Updating the Council on the Governor's Commuter Rail Advisory Task Force

Agenda of: May 1, 2018



Originator Information:

Originator: Mayor DeVries via City Manager Wallace

Department Review:

Route to:	Department Director:	Signature:	Date:
_____	Community Development	_____	_____
_____	Finance	_____	_____
_____	Fire	_____	_____
_____	Police	_____	_____
_____	Public Works	_____	_____

Approved for Presentation By:

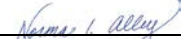
	Signature:	Remarks:
City Manager		_____
City Attorney		_____
City Clerk		_____

Certification of Funds:

Total amount of funds listed in this legislation: \$ 0.00

This legislation (√):

- Creates revenue in the amount of: \$ _____
- Creates expenditure in the amount of: \$ _____
- Creates a saving in the amount of: \$ _____
- Has no fiscal impact

Funds are (√):

- Budgeted Line item(s): _____
- Not budgeted _____

Director of Finance Signature: _____

Attachment(s):

- Commuter Rail Task Force Meeting Minutes March 30,2018

Summary Statement/Background:

The Governor's Commuter Rail Task Force was appointed in January 2018 to advise the Governor on the feasibility and implementation of a pilot project for a commuter rail system between the Matanuska-Susitna Valley and Anchorage using to the extent possible existing railroad infrastructure.

To date the task force has reviewed information provided by the Alaska Railroad, a commuter rail advisor (external), Alaska Department of Transportation, and various input from citizens and municipalities.

The last meeting included a presentation on costs of conducting the pilot. In general, it is believed there will need to be at least a \$10 million capital investment for the pilot project to take place with an additional \$3.9 million operating budget for one train and another \$3.5 million operating cost for a second train. This would support a winter commute pilot from October to April (give or take a month depending on tourism schedule).

The continuing costs of operating a commuter rail beyond the pilot were not captured at this time, but would include a maintenance facility, additional passenger and locomotives, and intermodal facilities for passenger transfers from one mode of transit to another.

No recommendation has been formulated to date, but it is expected that the task force will draft a recommendation or vote on a recommendation at the next meeting slated for May 4, 2018.

The Task Force is tasked to provide an initial recommendation to the Governor by May 31, 2018, with a final report due September 30, 2019.

Commuter Rail Task Force Meeting Minutes

Date/Time: March 30th, 1-3 pm

Location: Wasilla City Hall, Council Chambers (290 E Herning Avenue, Wasilla) / 907-373-3543

Attendees:

Bert Cottle*	Mayor of Wasilla (Co-Chair)	Jamie Acton for Craig Lyon*	AMATS Transportation Planning Mgr
Virgie Thompson*	Mayor of Houston	Cynthia Wentworth*	Public Member
Edna DeVries*	Mayor of Palmer	Dave Kemp	DOT&PF CR Director
Vern Halter*	Mat-Su Borough Mayor	Brian Lindamood	ARRC Director of Capital Projects
LaMarr Anderson*	Public Member	Ernest Piper	Chief Mechanical Officer, Keolis
Murph O'Brien	HDR	Megan Byrd	DOT&PF
Kenda Huling	Monday Market	Governor Bill Sheffield	Vice Chair, ARRC Board of Directors
Bob Hackinson	Member of Public	Eugene Haberman	Member of Public

*Indicates Appointed Task Force Member

Attending by phone:

Ona Brause For Ethan Berkowitz*	Mayor of Anchorage (Co-Chair)	Heather Parker	Policy & Program Analyst, Office of the Governor
------------------------------------	-------------------------------	----------------	---

Agenda

- Welcome (Bert Cottle)
- Review of recommendations (Members, 2-3min)
- Development of model
- Working Groups Identified
- Action Items
- Next meeting date
- Public Comment

Discussion

Welcome & Introductions: Mayor Cottle welcomed everyone to the meeting.

Lessons learned – March 22nd Glenn Hwy closure at South Eagle River overpass: Mayor Halter said he was impressed with the Alaska Department of Transportation and Public Facilities (DOT&PF) response to the Glenn Hwy Bridge closure incident. Director Kemp said that he thought the DOT&PF response went well, but in the future DOT&PF would make it a point to improve communications with APD.

Brian Lindamood, said Alaska Railroad Corporation (ARRC) had prepared commuter rail services in the event that the bridge and highway remained closed during the next week. ARRC did not have staff or rail cars prepared for dispatch on March 23rd, but felt that 48-72 hours would be a reasonable response time

without impacting existing scheduled service. Had the commuter rail service been in the pilot phase, providing for an influx of passengers would have been nearly seamless.

Review of recommendations: the task force briefly discussed the recommendations that were collected and distributed March 12th to members. The following concerns were discussed: the cost of the pilot program and infrastructure needed to stand the program up; the short turn around for the report due to the Governor’s office in August; commute times compared to drive times; amenities (WiFi, food service) and comfort of the rail cars; funding sources and stigma of subsidizing the costs; consistency and reliability during all seasons of operations; building a system that will fit the long term needs of the population; definition of a successful program, clear goals and measurable outcomes need to be agreed upon before the start of the pilot.

Ernie Piper agreed to draft sample goals for the groups’ discussion and reiterated that transit is about the people who live in the community, and what they want their community to look and feel like. It is important that the community guide the program. He gave the following as a guideline on creating subcommittees to discuss the two sides of the report that the task force should be focusing on.

Both groups should have members representing:	Pilot Program subcommittee should be focusing on:	Sustainable Service subcommittee should be focusing on:
ARRC	Engineering	Modes of Transportation connecting to Rail services.
ADOT&PF	Operations	Passenger comfort (food and beverages, WiFi, “Mobile office”, etc.)
JBER	Funding for set up	Equipment and Schedule
Communities Tribes Cities Individuals		Funding Sources: State, Local, Federal, Tribal, and the consequences and requirements of accepting different types of funding (Air Quality, ADA compliance, etc.)
		Governance Model
		Community Education

Additional concerns were that the existing infrastructure will not meet passenger comfort, ADA or Air Quality requirements; and upgrading the existing track system to make a faster commute time would have significant costs involved; with the expectation of the train taking 72 minutes (and up to 78 minutes with stops in Eagle River and JBER) to complete its route, the amenities on the train need to allow for the maximum use of that time for work related activities.

The city of Wasilla has already purchased a parking lot that will be used for the commuter rail depot, and plans to move the existing depot building to that lot. In the event that it is determined the commuter rail program is not sustainable the lot would be repurposed for park and ride parking.

Public comments: members of the public were given an opportunity to comment on the record.

Governor Bill Sheffield thanked the group and was glad to see the program moving along.

Eugene Haberman was concerned that there was not enough public notice given, and that the time of the meetings did not allow for members of the working public to attend.

Kenda Huling was excited for the possibilities of commuter services being extended outside of the normal work week/hours. For those valley residents that would like to work in Anchorage, but do not have regular transportation and would likely be working on the weekends and evenings outside of the Valley Mover hours of operations. Extended hours would also allow for use for students attending sporting and other events, dining, and airport transit options.

Murph O'Brien was happy to see the progress being made and suggested that community education be added to the above chart.

Action Items:

Item		Responsible	Status
1	Distribution of subcommittee selection chart	Megan Byrd	
2	Task Force members select which subcommittee(s) they will be members of	Task Force Members	
3	Determine what a successful program would look like, come up with measurable goals for success.	Subcommittees	Mr. Piper is preparing sample goals to distribute to the subcommittee members.
4	Subcommittees meet with Ernie Piper to better understand each group's role.	Subcommittees	Mr. Piper will be in Alaska 4/14-20/18. once subcommittees are determined dates will be set for these meetings.

Next Meeting: Tentatively scheduled for 4/20/18 in Anchorage. Location TBD.