

Mayor Steven J. Carrington
Deputy Mayor Pamela Melin
Council Member Carolina Anzilotti
Council Member John Alcantra
Council Member Richard W. Best
Council Member Thomas Ojala IV
Council Member Joshua Tudor

City Manager John Moosey
City Clerk Shelly M. Acteson, CMC
City Attorney Sarah Heath, Esq.

City of Palmer, Alaska
Regular City Council Meeting
May 23, 2023, at 6:00 PM
City Council Chambers
231 W. Evergreen Avenue, Palmer
www.palmerak.org

AGENDA

A. CALL TO ORDER

B. ROLL CALL

C. PLEDGE OF ALLEGIANCE

D. APPROVAL OF AGENDA

1. Approval of Consent Agenda
2. Approval of Minutes of Previous Meetings
 - A. May 9, 2023, Joint Special Meeting with Parks and Recreation Advisory Board
 - B. May 9, 2023, Regular Meeting

E. COMMUNICATIONS AND APPEARANCE REQUESTS

1. Proclamation Recognizing the Mat-Su Miners
2. Proclamation Recognizing Memorial Day
3. Proclamation Recognizing Matanuska Valley Credit Union's 75 Years of Service to the Community
4. Presentation - Saroma Sister City School Delegation

F. REPORTS

1. City Manager's Report
2. Mayor's Report
3. City Clerk's Report
4. City Attorney's Report

G. AUDIENCE PARTICIPATION

H. PUBLIC HEARINGS

1. **Resolution No 23-014:** Authorize the Purchase and Appropriate Funds in the Principal Amount Not to Exceed \$341,369.00 to Finance the Purchase of a New 821G Wheel Loader from Yukon Equipment, Inc., for Public Works in the Amount of \$341,369.00 as a Direct Replacement for the Existing 1999 Wheel Loader
2. **Resolution No. 23-015:** Authorize the City Manager to Advance \$583,482 from the General Fund Unassigned Fund Balance to the Water and Sewer Fund for the Insulation Repairs to Reservoir 4 Heavily Damaged in the January 2022 Windstorm
3. **Resolution No. 23-016:** Accepting and Appropriating Healthy & Equitable Communities Grant Funds from the State of Alaska, Department of Health and Social Services, and Division of Public Health in the Amount of \$89,078 to Provide Funding to Alaskan Local Governments in Support of Creating and Sustaining Healthy and Equitable Communities Around the State

I. ACTION MEMORANDA

1. **Action Memorandum No. 23-030:** Approving a Request from Arctic Winter Games 2024 to

Waive Facility Use Fees up to \$32,205 for the Usage of the MTA Events Center and the Palmer Train Depot during March of 2024

2. **Action Memorandum No. 23-031:** Authorize the City Manager to Negotiate, Execute and Commit a Downpayment of \$25,000 for a Sole Purchase of An Ice Resurfacer from Zamboni Company USA, Inc.
3. **Action Memorandum No. 23-032:** Authorize the City Manager to Execute Change Order Number Four Option with Alaska Sure Seal in the Amount of \$46,000 for Yellow Curb Painting along roadways
4. **Action Memorandum No. 23-033:** Authorizing Utility Connection for AMG & Associates, Located at 12821 E. Scott Road, Palmer, Alaska
5. **Action Memorandum No. 23-034:** Authorize the City Manager to Execute a Contract with HDL Engineering Consultants in the Amount not to exceed \$32,545.00 for Construction Administration Services for Reservoir #4 Insulation Repairs Project
6. **Action Memorandum No. 23-035:** Authorize the City Manager to Negotiate and Enter into a Contract with Northern Insulation Solutions Inc., in an Amount Not to Exceed \$867,568.00 for the 2023 Palmer Reservoir 4 Insulation Repairs Project
7. **Action Memorandum No. 23-036:** Authorize the City Manager to Purchase, Under the Governmental and Proprietary Procurements Section of Palmer Municipal Code 3.21.2350, 50 Used Golf Carts Not to Exceed \$125,000
8. **Action Memorandum No. 23-037:** C Authorizing the City Manager to Execute a Contract with HDL Engineering Consultants in the Amount not to exceed \$32,510 for Construction Administration Services for the 2023 Evergreen Avenue and Airport Road Pathway Project

J. UNFINISHED BUSINESS

K. NEW BUSINESS

L. RECORD OF ITEMS PLACED ON THE TABLE

M. AUDIENCE PARTICIPATION

N. EXECUTIVE SESSION

O. COUNCIL MEMBER COMMENTS

P. ADJOURNMENT

Tentative Future Palmer City Council Meetings

Meeting Date	Meeting Type	Time	Notes
June 13, 2023	Regular	6 pm	
June 27, 2023	Regular	6 pm	
July 11, 2023	Regular	6 pm	
July 25, 2023	Regular	6 pm	

A. CALL TO ORDER

A regular meeting of the Palmer City Council was held on May 9, 2023, at 6:00 p.m. in the Council Chambers, Palmer, Alaska. Mayor Carrington called the meeting to order at 6:00 p.m.

B. ROLL CALL

Comprising a quorum of the Council, the following were present:

Mayor Steve Carrington, Deputy Mayor Pam Melin, Joshua Tudor, Thomas Ojala IV, Richard W. Best, John Alcantra, and Carolina Anzilotti

Staff in attendance:

- Shelly M. Acteson, CMC, City Clerk
- Holly Dubose, Deputy City Clerk
- Sarah Heath, City Attorney
- Gina Davis, Finance Director

C. PLEDGE OF ALLEGIANCE

The Pledge of Allegiance was performed.

D. APPROVAL OF AGENDA

Main Motion: To Approve the Agenda with Council Comments moved before Action Memorandum

Moved by:	Best
Seconded by:	Alcantra
Vote:	Unanimous
Action:	Motion Carried

E. COMMUNICATION AND APPEARANCE REQUESTS

1. **Proclamation Recognizing the Palmer High School Cheer Team**
Deputy Mayor Melin presented the Palmer High School Cheer Team with a proclamation.
2. **Proclamation Recognizing Palmer High School Female Athlete of the Year Torrey McClain**
Council Member Anzilotti presented Torrey McClain with a proclamation for female athlete of the year.
3. **Proclamation Recognizing Palmer High School Male Athlete of the Year Kayson Asay**
Council Member Best presented Kayson Asay with a proclamation for male athlete of the year.

Mayor Carrington called a recess at 6:10 p.m., meeting reconvened at 6:12 p.m.

4. **Presentation - City Finance Director Gina Davis, Alaska Remote Sellers Sales Tax**
Gina Davis, Finance Director, gave an overview of seller's sale tax.

Discussion followed and Ms. Davis responded to Council questions.

F. REPORTS

1. City Manager's Report

- Auditors will be on site until June.
- The Great Alaska Aviation Gathering was successful this past weekend.
- Palmer Clean Up starts Saturday at 9:00 a.m.
- Requested to postpone the SRO legislation until the next Council meeting.

2. Mayor's Report

- Provided an overview of the written report in the packet.
- Met the auditors this last week.
- Commented positively on the Aviation Gathering.
- Noted the car show was last weekend.

3. City Clerk's Report

- No formal report.

4. City Attorney's Report

- Volunteered at the Aviation Gathering last weekend.
- Attended a meeting with local business owners and distributed a fact sheet of common criminal offense nuances to local Palmer businesses.

G. AUDIENCE PARTICIPATION

Travis Friesen:

- Commented on recycling in the City of Palmer.

Jackie Goforth:

- Spoke on the book "Let's Talk About It".

Eric Anderson:

- Commented on recycling.

Marcie Benti:

- Commented on traffic in Palmer.

Cindy Hudgins:

- Commented on a recent event in Texas.

Susan Powder:

- Noted the processes in place for banning books.
- Mentioned concerns with recent actions taken towards the library.

Mike Chmielewski:

- Commented on Veteran's Memorials and encouraged the city to make sure bike lanes are visible.

Kelsey Anderson:

- Commented that the City Council should not determine what books belong in the library.

H. PUBLIC HEARINGS

1. **Resolution No. 23-012:** Accepting and Appropriating the 2023 State of Alaska High Visibility Click It Or Ticket Enforcement Grant 402 BIL PT-23-06-BL(A)-3 in the Amount of \$4,480 to be used for High Visibility Seatbelt Enforcement Activities by the Palmer Police Department

Chief Shelton provided a staff report.

Mayor Carrington opened the public hearing.

Seeing no one come forward, Mayor Carrington closed the public hearing.

Main Motion: To Approve Resolution No. 23-012.

Moved by:	Alcantra
Seconded by:	Tudor
Vote:	Unanimous
Action:	Motion Carried

2. **Resolution No. 23-013:** In Support of The Designation of The Mat-Su Valley Planning For Transportation (MVP For Transportation) as the Metropolitan Planning Organization (MPO) of the Mat-Su Area.

Mayor Carrington opened the public hearing.

Cindy Hudgins:

- Commented in opposition of Resolution 23-013.

Jerad Anderson:

- Commented in support of Resolution 23-013.

Mike Chmielewski:

- Commented in support of Resolution 23-013.

Jackie Ivie Goforth:

- Commented in opposition of Resolution 23-013.

Travis Friesen:

- Commented in support of Resolution 23-013.

Kelsey Anderson:

- Commented in support of Resolution 23-013.

Eric Anderson:

- Commented in opposition of Resolution 23-013.

Seeing no others come forward, Mayor Carrington closed the public hearing.

Manager Moosey provided a staff report.

Discussion followed and Manager Moosey responded to Council questions, and Council directed the Manager to invite a member of the current MPO in Fairbanks to participate in the June 13 Council Meeting, under the Committee of the Whole.

Main Motion: Legislation was moved to the May 23 meeting, under public hearing

Moved by:	
Seconded by:	
Vote:	Unanimous Consent
Action:	Motion Carried

I. COUNCIL MEMBER COMMENTS

Council Member Tudor:

- Thanked everyone for coming out to the meeting tonight.
- Great joint meeting with Parks and recreation Advisory Board.
- Good turnout for Great Alaskan Aviation Gathering this last weekend.
- Congratulations to all the seniors graduating.
- Mother’s Day Reminder.

Council Member Ojala IV:

- Appreciated everyone’s participation this evening.
- Thanked the public for reaching out to their Council person.
- Thanked Gina Davis for her presentation.
- Commented on recycling in Alaska.

Council Member Best:

- Thanked the Parks and Recreation Advisory Board for their updates.
- Requested support to direct the Attorney to review City Code of Ethics review for redundancy and conflicts, or any advice to the Council, Council Member Anzilotti offered support. A Roll Call VOTE was taken; unanimous.
- Participated in the Great Alaskan Aviation Gathering.
- Thanked Public Works staff for their efforts with the street cleaning.

Council Member Alcantra:

- Commented on the MPO legislation.
- Reminder of Clean-up Day this next Saturday.
- Palmer Graduation next Tuesday evening.
- Will be absent from the May 23 meeting.

Council Member Anzilotti:

- Commented on the MPO legislation.
- Thanked business owner Wes Artz for putting together the business group meeting.
- Thanked the Parks and Recreation Advisory Board for their updates.
- Friday Fling is this Friday.

Council Member Melin:

- Thanked the members of the community for attending the Council meeting this evening.
- Thanked Public Works for their efforts with the street clean up.
- Requested support to direct Manager Moosey to review parking issues and create a parking plan with support from Council Member Ojala IV.
- Requested support to direct Manager Moosey to investigate if there are any resolutions to resolve the smell of the treatment plan with support from Council Member Anzilotti.

Mayor Carrington called for a recess at 8:27 p.m., the meeting reconvened at 8:37 p.m.

J. ACTION MEMORANDA

1. **Action Memorandum No. 23-024:** Authorize the City Manager to Enter into an Agreement for a 5-year contract for a Safety Resource Officer (SRO) at Colony High School

Mayor Carrington stated, at the request of the Manager, Action Memorandum 23-024 was postponed to a future meeting.

Main Motion: To Approve Action Memorandum No. 23-024.

Moved by:	Anzilotti
Seconded by:	Ojala IV
Vote:	Unanimous
Action:	Motion Carried

2. **Action Memorandum No. 23-025:** Authorize the City Manager to Negotiate and Execute a One Year Contract with the Matanuska-Susitna Borough to Provide Fire Emergency Response to the Greater Palmer Fire Service Area (GPFSA)

Manager Moosey provided a staff report.

Main Motion: To Approve Action Memorandum No. 23-025.

Moved by:	Best
Seconded by:	Tudor
Vote:	Unanimous
Action:	Motion Carried

3. **Action Memorandum No. 23-026:** Liquor License Renewal for Loyal Order of Moose Lodge #793

Main Motion: To Approve Action Memorandum No. 23-026.

Moved by:	Melin
Seconded by:	Ojala IV
Vote:	Unanimous
Action:	Motion Carried

4. **Action Memorandum No. 23-028:** Authorize the City Manager to Negotiate and Enter into a Contract with Ahtna Construction Primary Products Company, LLC., in an Amount Not to Exceed \$425,002, for the 2023 Evergreen Avenue & Airport Road Pathway Project

Public Works Director Jude Bilafer provided a staff report.

Main Motion: To Approve Action Memorandum No. 23-028.

Moved by:	Best
Seconded by:	Alcantra
Vote:	Unanimous
Action:	Motion Carried

5. **Action Memorandum No. 23-029:** Authorize the City Manager to Execute Change Order Number Three for the Second Renewal Option with Alaska Sure Seal in the Amount of \$153,961.65 for Crack Sealing roadways, runways, parking aprons, infrared pothole patching and street line striping in

Main Motion: To Approve Action Memorandum No. 23-029.

Moved by:	Melin
Seconded by:	Anzilotti
Vote:	Unanimous
Action:	Motion Carried

K. UNFINISHED BUSINESS

L. NEW BUSINESS

M. RECORD OF ITEMS PLACED ON THE TABLE

3 MPO documents from Manager Moosey

N. AUDIENCE PARTICIPATION

Travis Friesen:

- Commented on recycling initiatives in Palmer.

Erik Anderson:

- Commented on recycling.

Jackie Goforth:

- Commented on reading and libraries.

Cindy Hudgins:

- Remarked on libraries.

P. EXECUTIVE SESSION

Q. ADJOURNMENT

With no further business before the Council, the meeting adjourned at 9:05 p.m.

Approved this 23th day of May, 2023.

Shelly M. Acteson, CMC, City Clerk

Steve Carrington, Mayor

A. CALL TO ORDER

A joint special meeting of the Palmer City Council was held on May 9, 2023, at 5:00 p.m. in the Council Chambers, Palmer, Alaska. Mayor Carrington called the meeting to order at 5:00 p.m.

B. ROLL CALL

Comprising a quorum of the Council, the following were present:

Mayor Steve Carrington, Deputy Mayor Pam Melin, Joshua Tudor, Thomas Ojala IV, Richard W. Best, John Alcantra, and Carolina Anzilotti.

Staff in attendance:

Shelly M. Acteson, CMC, City Clerk
Brad Hansen, Acting City Manager
Holly Dubose, Deputy City Clerk
Sarah Heath, City Attorney

Parks and Recreation Advisory Board:

Ryan Richard, Chair
Lisa Albert-Konecky
Richell Carmichael
Morgan Christensen (absent)
Johana McMahan
Joseph Parreira III (absent)
Marilyn Bennett (absent)

C. PLEDGE OF ALLEGIANCE

The Pledge of Allegiance was performed.

D. APPROVAL OF AGENDA

Main Motion: To Approve the Agenda as presented

Moved by:	
Seconded by:	
Vote:	Unanimous Consent of Council and Board Members present
Action:	Motion Carried

E. AUDIENCE PARTICIPATION

Mike Chmielewski:

- Commented on the need for connecting green spaces in the City of Palmer.

F. NEW BUSINESS

Main Motion: To Enter into Committee of the Whole

Moved by:	Melin
Seconded by:	Anzilotti
Vote:	Unanimous Vote by Council and Board Members present
Action:	Motion Carried

1. Committee of the Whole (note: action may be taken following the committee of the whole)

Ryan Richard, Parks and Recreational Advisory Board Chair gave an update on current projects and upcoming efforts of the Board.

- a. 2023 Board Projects and Goals
- b. Other Matters Related to the Parks and Recreation Advisory Board
- c. City Council Direction to the Board

Hearing no objection, Mayor Carrington motioned to exit Committee of the Whole at 5:35 p.m.

Mayor Carrington moved to direct Manager Moosey to bring a Resolution forth suggested funding in the amount of \$5,000 with support from Council Member Best.

Discussed followed and Ryan Richard responded to Council questions.

G. ADJOURNMENT

With no further business before the Council, the meeting adjourned at 5:39 p.m.

Approved this 23th day of May, 2023.

Shelly M. Acteson, CMC, City Clerk

Steve Carrington, Mayor



PROCLAMATION

A PROCLAMATION RECOGNIZING THE MATSU MINERS AND RECOGNIZING THEIR CONTRIBUTIONS TO THE CITY OF PALMER

WHEREAS, the Mat-Su Miners have proudly represented Palmer, Alaska, and the greater Matanuska-Susitna Valley for over forty-seven years, providing thrilling summer collegiate baseball games for both the local community and visiting fans; and

WHEREAS, since their founding as the Valley Green Giants in 1976, the team has undergone one name change, won two National Baseball Congress Championships, and has seen close to 400 former Miners go on to play professional baseball, including 72 who have reached the Major Leagues; and

WHEREAS, the Mat-Su Miners have consistently demonstrated their commitment to excellence and their community, with six first-place finishes and ten second-place finishes from 2004 through 2022; and

WHEREAS, Hermon Brothers Field, the home of the Mat-Su Miners, serves as a testament to the team's dedication and the support of the local community, with countless volunteers and local businesses contributing time, materials, and resources to build, maintain, and improve the field over the years; and

WHEREAS, the Mat-Su Miners have continued to upgrade and enhance Hermon Brothers Field, creating a top-notch facility for players and spectators, while also benefiting the broader Matanuska-Susitna Borough through year-round use and community engagement; and

WHEREAS, the Mat-Su Miners' rich history and continuous growth exemplify the resilience, spirit, and heart of the team, their fans, and the surrounding community in the picturesque Matanuska Valley;

NOW, THEREFORE, the mayor and city council of the city of Palmer, do hereby proclaim June 5, 2023 as

Mat-Su Miners' Day

FURTHER, we recognize and honor the Mat-Su Miners for their dedication, achievements, and impact on the community, and extend our heartfelt appreciation for their continued contributions to the world of baseball and the people of Palmer, Alaska, and the Matanuska-Susitna Valley.

IN WITNESS WHEREOF, I have hereunto set my hand and caused the Seal of City of Palmer to be affixed this 23rd day of May 2023.

Steve Carrington, Mayor

Shelly Acteson, CMC, City Clerk



PROCLAMATION

A PROCLAMATION HONORING MEMORIAL DAY 2023

WHEREAS, each year, Memorial Day serves as a reminder to honor the men and women of our country who have fallen while serving in the US military; and

WHEREAS, in 1868, Major General John Logan called for nationwide Remembrance Day to pay tribute to those who gave their lives defending our country; and

WHEREAS, the resolution approved by Congress on May 11, 1950, called to set aside the Memorial Day as a day of prayer for all fallen heroes, for a peaceful and brighter future for generations to come; and

WHEREAS, it is our duty to remember our brave warriors and their heroic fight for security of our land and freedom. We must pledge that their sacrifice will not go in vain or be forgotten.

NOW, THEREFORE, IT IS PROCLAIMED by the Mayor and City Council of the City of Palmer, hereby recognize May 29, 2023, as Memorial Day and encourage residents of Palmer honor with a moment of silence for our fallen heroes.

IN WITNESS WHEREOF, I have hereunto set my hand and cause the seal of the City of Palmer to be affixed on this __th day of May, 2023.

Steve Carrington, Mayor

Shelly M Acteson, CMC, City Clerk



PROCLAMATION

A PROCLAMATION RECOGNIZING MATANUSKA VALLEY CREDIT UNION'S 75 YEARS OF SERVICE TO THE COMMUNITY

WHEREAS, Matanuska Valley Federal Credit Union (MVFCU), rooted in the heart of Palmer, Alaska, is celebrating 75 years of dedicated service to our community; and

WHEREAS, since its establishment in 1948, MVFCU has steadfastly upheld its commitment to helping its members build a better financial future, exhibiting the power of collective action and the strength of familial bonds; and

WHEREAS, MVFCU, as a not-for-profit financial cooperative, is a testament to the power of community ownership and control, embodying the essence of democratic principles in its operations; and

WHEREAS, MVFCU empowers its members by granting them the dual role of being both members and shareholders, thus providing them a voice in shaping the credit union's future, reinforcing the belief that together, we can indeed do better; and

WHEREAS, the elected Board of Directors, comprised of volunteer community members, stands as a symbol of MVFCU's commitment to its members and community; and

WHEREAS, MVFCU, through its responsiveness to members' needs, offers a comprehensive range of financial services that combine convenience with flexibility, demonstrating its not-for-profit ethos by extending lower loan rates and better savings rates, thereby contributing to the financial well-being of its members; and

NOW, THEREFORE, the mayor and city council on behalf of the City of Palmer, do hereby proclaim May 25, 2023 as

Matanuska Valley Federal Credit Union Day

FURTHER, we express our profound gratitude and appreciation to Matanuska Valley Federal Credit Union for its 75 years of exemplary service, and for its continuous efforts to build a better financial future for its members and our community.

IN WITNESS WHEREOF, I have hereunto set my hand and cause the seal of the city of Palmer to be affixed on this 23rd day of May 2023.

Steve Carrington, Mayor

Shelly Acteson, CMC, City Clerk



Palmer Mayor's Report

May 23, 2023, Council Meeting

Meeting Agenda Highlights:

We have three **proclamations**:

- Proclamation Recognizing the Mat-Su Miners
- Proclamation Recognizing Memorial Day
- Proclamation Recognizing Matanuska Valley Credit Union's 75 Years of Service to the Community

We have one presentation:

- Carla Swick with the Saroma Sister City School Delegation will bring the student delegations and introduce them to the City Council on May 23rd.
- Palmer High School Delegation: Emma Keechle, Makenna Pickett, Maggie Whisenhunt, Jacob Saunders, Jaimeson Roa, Zachary Riedel and Carla Swick.
- Palmer Junior Middle School Delegation: Cyrus Pilgreen, Audrey Jordan, Audrey Zickefoose, Erin Pilgreen and Aemilia-Simone Maclean.
- "Even a thousand mile journey begins with one step" – Japanese proverb

There are three **public hearings**:

- Reso 23-014: is for funding to purchase a new wheel loader to replace our existing 1999 model wheel loader.
- Reso 23-015 is an advance of fund from the General Fund to the Water and Sewer Fund for Reservoir 4 insulation repairs.
- Reso 23-016 is a "pass-through" grant from the Alaska Dept. of Health through the city to DayBreak Inc. DayBreak wants to spearhead a pilot project to "improve health outcomes for underserved Palmer residents, specifically targeting those struggling with homelessness, mental health and substance use disorders..." Attached to the resolution is a draft Memo of Agreement between DayBreak and the City.

There are eight **Action Memoranda** with topics ranging from Arctic Winter Games 2024, a Zamboni, Curb Painting, utility connections, construction administration, reservoir insulation repairs, and golf carts.



Palmer Mayor's Report

With this agenda I decided to take a break on the MVP/MPO discussion and public hearings. We are hoping to have someone from the Fairbanks MPO available at our June 13, 2023 city council meeting and will have another public hearing and committee of the whole at that meeting. In the meantime, here are some links for those wishing to understand the MVP for Transportation (Mat-Su Valley Planning For Transportation) issue further:

- <https://www.mvpmpo.com/>
- <https://www.mvpmpo.com/operating-documents>
- <https://www.mvpmpo.com/mpo-regulations-and-resources>
- <https://www.mvpmpo.com/pre-mpo-policy-board>
- <https://www.mvpmpo.com/steering-committee>
- <https://www.planning.dot.gov/mpo/default.aspx>
- <https://t4america.org/2023/05/03/full-steam-ahead/>

Rebarchek Pit

There has been some questions about the East Rebarchek Avenue CUP (Conditional Use Permit) and AK Demo. Here are some history points:

- About 39 acres in size
- Rebarchek gravel pit active from 1963 to 2002
- Annexed into the city in 2003 and auto-zoned R-1
- Rezoned to I-Industrial with Special Limitations and CUP (Conditional Use Permit)
- Operated for 10 years as inert waste mono-fill
- Continued operation under Permit & Special Limitations extended to expire Feb. 1, 2029

If the council is interested we can schedule a staff report at a future meeting to allow for more questions and discussion.

Recent Meetings and Events:

We are hosting the Mayors/Managers meeting at Palmer City Hall Thursday, May 18, 2023.



Palmer Mayor's Report

Upcoming Meetings and Events

- May 29 @ 1 p.m. -- Memorial Day Ceremony honoring fallen military members. Deputy Mayor Pam Melin will be attending and reading our proclamation.
- June 9-11 is Colony Days in downtown Palmer including the The *Colony Days* Parade, Saturday, June 10th, at 11am in Downtown Palmer! This year's theme is "Celebrating Summer"
- The Alaska Scottish Highland Games will be at the Alaska State Fairgrounds. Saturday, June 24, 2023, and Sunday, June 25, 2023!

Mayor Steve Carrington

**City of Palmer
Resolution No. 23-014**

Subject: Authorize the Purchase and Appropriate Funds in the Principal Amount Not to Exceed \$341,369.00 to Finance the Purchase of a New 821G Wheel Loader from Yukon Equipment, Inc., for Public Works in the Amount of \$341,369.00 as a Direct Replacement for the Existing 1999 Wheel Loader

Agenda of: May 23, 2023

Council Action: **Approved** **Amended:** _____
 Defeated

Originator Information:

Originator: Jude Bilafer, Director of Public Works

Department Review:

Route to:	Department Director:	Signature:	Date:
_____	Community Development	_____	_____
_____	Finance	_____	_____
_____	Fire	_____	_____
_____	Police	_____	_____
X	Public Works		05/04/2023

Certification of Funds:

Total amount of funds listed in this legislation: \$ **341,369.00**

- This legislation (√):
- Creates revenue in the amount of: \$ _____
 - Creates expenditure in the amount of: \$ **341,369.00**
 - Creates a saving in the amount of: \$ _____
 - Has no fiscal impact

Funds are (√):

- Budgeted Line item(s): 09-01-10-6054 Public Works Equipment
- Not budgeted

Director of Finance Signature: 

Approved for Presentation By:

	Signature:	Remarks:
City Manager		_____
City Attorney	_____	_____
City Clerk	_____	_____

Attachment(s):

1. RESO No. 23-014
2. 821G Wheel Loader Quote
3. 821G Wheel Loader Specification Sheets.

Summary Statement/Background:

This resolution requests the authorization to purchase one new 821G Wheel Loader Yukon Equipment, Inc. and to appropriate the funds from the unassigned General Fund balance.

This wheel loader will replace a 24-year-old loader which no longer functions reliably. In the 24 years since the current wheel loader's purchase, the demand for its use has nearly tripled. This loader is used for in every aspect of Public Works activities – snow removal, road repairs, general construction, and repairs. The current wheel loader routinely breaks down and is unreliable. Compound this with challenges getting replacement parts due to the loader's age and a new loader is warranted.

The City of Palmer Administration chose this loader as a direct replacement of its existing unit and to take advantage of the existing Sourcwell Government contract.

3.21.230 Governmental and proprietary procurements.

A. The purchasing officer may contract, without the use of the competitive source selection procedures of this chapter, for the following supplies, services, professional services, or construction:

1. For contracts, including reimbursable agreements, with federal, state, or local units of government or utility provider where the city has a financial responsibility or beneficial interest in entering into an agreement.
2. For contracts issued pursuant to any federal, state, or local government contract where the city is an authorized user, or where the resulting contractor agrees to extend the same terms, conditions, and pricing to the city as those awarded under the original contract, all in accordance with PMC 3.21.240. Such agreements shall be limited to those contracts where the award is issued pursuant to a formally advertised solicitation.
3. For contracts where the purchasing officer determines in writing that the city's requirements reasonably limit the source for the supplies, services, professional service, or construction to one person.

B. All contract awards under this section, and any amendments thereto, shall be subject to the applicable approval requirements of PMC 3.21.090 prior to execution.

C. No contractor may provide supplies, services, professional services, or construction to the city before the applicable requirements of this section are first satisfied. (Ord. 644 § 4, 2004)

Administration's Recommendation:

Approve Resolution No. 23-014 and Transfer Funds not to Exceed \$341,369.00 to finance the Purchase of a new 821G Wheel Loader from Yukon Equipment, Inc.

LEGISLATIVE HISTORY

Introduced by:
Date:
Public Hearing:
Action:
Vote:

Yes:

No:

--	--

CITY OF PALMER, ALASKA

Resolution No. 23-014

A Resolution of the City Council of the City of Palmer, Alaska, Authorizing the City of Palmer to Appropriate Funds from the Unassigned General Fund Fund Balance in the Principal Amount Not to Exceed \$341,369.00 to Finance the Purchase of a New 821G Wheel Loader from Yukon Equipment, Inc

WHEREAS, the City of Palmer, Alaska (the "City") is a home rule city and under Section 11 of Article X of the Alaska Constitution may exercise all legislative power not prohibited by law or the charter of the City, and the City has determined that the matters set forth in this resolution are not prohibited by law or the charter; and

WHEREAS, the City's Current Wheel Loader is over 24 Years Old, Unreliable, and cannot keep up with the increased demands; and

WHEREAS, the City's current Wheel Loader is unreliable, frequently experiences significant mechanical breakdowns, and incurs long delays when ordering repair/replacement parts; and

WHEREAS, it is required and necessary and in the best interest of the City and its residents that the City authorize the transfer of these funds for the purposes described in this Resolution.

NOW, THEREFORE, BE IT RESOLVED, the Palmer City Council hereby appropriates funding from the Unassigned General Fund fund balance for the Purchase of a new 821G Wheel Loader from Yukon Equipment, Inc., in an amount not to exceed \$341,369.00

Approved by the Palmer City Council this _____ day of _____, 2023.

Steve Carrington, Mayor

Shelly Acteson, CMC, City Clerk



Serving Alaska since 1945
www.yukoneq.com

Anchorage
2020 East 3rd Ave.
Anchorage, AK 99501
(907) 277-1541

Fairbanks
3511 International St.
Fairbanks, AK 99701
(907) 457-1541

Wasilla
450 E. Railroad Ave.
Wasilla, AK 99654
(907) 376-1541

Quote Date: 04/13/23
Prepared By: Ronnie Malerich
Direct Line: 907-677-5727
Cell: 907-312-6582
Email: Ronniem@yukoneq.com

QUOTE FOR: City of Palmer
CONTACT: Greg Wickham
PHONE: 907-863-0742
EMAIL: gwickham@palmerak.org

QUOTATION
QUOTE VALID THROUGH
05/13/2023

**One 821G Wheel Loader
Per Configuration #0701748961**

Additional Items Not Listed in Configuration

- **WBM WLKAT Hitch (Compatible with 721 Hitch)**
- **WBM 9' Forks**

Pricing:

821G List Price: \$443,939.00
Sourcewell Discount 37%: -\$168,700.00
Attachments: \$36,500.00
PDI & Setup: \$3,240.00
Freight FOB Palmer AK: \$26,390.00
Total: \$341,369.00

**Freight is based on current rates and is subject to change pending rate changes
& fuel surcharges**

Accepted: _____ Date: _____



ENGINE

Make	FPT
Model	F4HFE613S
Emissions Certification	Tier 4 Final
Emissions Technology	SCR/DOC
Type	4-stroke, turbocharged and air-to-air cooled
Cylinders	6-cylinder in-line
Bore/Stroke	4.09 x 5.20 in (104 x 132 mm)
Displacement	411 in ³ (6.7 L)
Fuel	#2 Diesel, #1 and #2 mixture permitted for cold temperatures
Fuel injection	Direct injection – electronic
Fuel filter	Replaceable, spin-on cartridge
Fuel pump	Bosch CP 3.3
Gradeability:	
Side-to-side	35°
Fore and aft	35°
Air filter	Dry type elements w/ warning restriction indicator
Mid-mount cooling module w/ auto reversing fan:	
Mid-mount Air/Water w/ Lube Oil Cooler	
Fan – hydraulic driven:	
Style	8 blade puller
Diameter	32 in (813 mm)
Water pump	Integral
Engine oil pump operating angle ratings:	
Side-to-side	35°
Fore and aft	35°
Oil filtration	Replaceable, full flow spin-on cartridge
Engine speeds	RPM
Rated – full load	2000
Horsepower – Maximum Power:	
Peak gross @ 1800 RPM	230 hp (172 kW)
Net rated @ 2000 RPM	206 hp (153 kW)
Peak net @ 1800 RPM	213 hp (159 kW)
Torque – Maximum Power:	
Gross @ 1300 RPM	873 lb-ft (1 184 N-m)
Net @ 1300 RPM	845 lb-ft (1 145 N-m)
Net torque rise:	
Maximum power range	56%

NOTE: Gross horsepower and torque per SAE J1995.
Net horsepower and torque per SAE J1349.

DRIVETRAIN

Transmission:	4F/3R Proportional w/ Electronic Control Module torque sensing autoshift/manual shift and modulation	
Gears	Helical cut	
Gear ratios – 4-speed	Forward/Reverse	
1st	3.754/3.551	
2nd	2.184/2.071	
3rd	1.072/1.017	
4th	0.636/ —	
Gear ratios – 5-speed	Forward/Reverse	
1st	3.921/3.718	
2nd	2.255/2.138	
3rd	1.466/0.894	
4th	0.942/ —	
5th	0.613/ —	
Torque converter:		
Stall ratio – 4-speed	2.283:1	
Stall ratio – 5-speed	2.420:1	
Differential:	Limited slip w/ 67% available axle torque to wheel w/ traction	
Rear axle oscillation	24° total	
Front and rear axles:		
Differential ratio	4.11	
Planetary ratio	6.00	
Final axle ratio	24.67	
Heavy-duty axles – optional:		
Front axle equipped w/ locking differential		
Rear axle equipped w/ open differential		
Planetaries	Outboard	
Service brakes:	Hydraulically actuated, maintenance-free, multiple wet disc w/ accumulator to all four wheels	
Brake surface area:		
Rear hub	600 in ² (0.387 m ²)	
Front and opt. rear hub	721 in ² (0.465 m ²)	
Parking brakes:	Spring-applied hydraulic release disc on transmission output shaft neutralizes power flow to wheels when engaged	
Travel speeds – 4-speed transmission:		
	Forward	Reverse
	mph (kph)	mph (kph)
1st	4.4 (7.1)	4.7 (7.5)
2nd	7.4 (12.0)	7.8 (12.6)
3rd	14.5 (23.3)	15.2 (24.4)
4th	22.8 (36.6)	—
Travel speeds – 5-speed transmission:		
	Forward	Reverse
	mph (kph)	mph (kph)
1st	4.1 (6.6)	4.4 (7.0)
2nd	7.1 (11.4)	7.4 (12.0)
3rd	10.6 (17.1)	17.2 (27.7)
4th	16.4 (26.4)	—
5th	24.9 (40.0)	—

NOTE: Travel speeds at full engine throttle w/ 23.5-R25 L3 Radial tires.

ELECTRICAL

Voltage	24 Volts, negative ground
Alternator	120 amp
Batteries (2)	12-volt

OPERATOR ENVIRONMENT

ROPS cab AC w/ heat; 8" LCD touchscreen display, adjustable armrest w/ 3 configurable buttons; Key start; Articulated power steering w/ tilt column; Fully adjustable, suspension seat w/ headrest; Foot throttle; Single lever (joystick) loader control w/ auxiliary function and fully adjustable wrist rest, 2 cup holders; Interior rear view mirror; 3 inch (76 mm) retractable seat belt; Integrated 4-corner strobe; Multiple storage trays; Single brake pedal; F/N/R shuttle switch; Left and Right external rear view mirrors; Pressurized air filtering; Anti-glare window strip; Front and Rear Defroster; Side window, partial/fully open; 2 Dome lights; Wipers, rear and intermittent front; Windshield washers, front and rear; Rubber floor mat; Horn; Radio ready – Includes antenna, speakers, wiring, radio fuse, 20A converter, 12-volt auxiliary power outlet, and USB outlet.

Displays/Gauges:

Digital:

Transmission oil temperature; Engine coolant temperature; Fuel level; DEF level.

LCD screen:

Hour meter; Engine speed; Travel speed; Time; Automatic transmission indication; Current gear selection; FNR indication; DeClutch indication; Engine mode indication; Trip computer A/B; Fuel consumption; Multiple languages, Metric/English; Engine diagnostics; Transmission diagnostics; Warning prompts; Error reporting; Diff. Lock*.

Audible/Visual alarms:

Warning lights:

Four-way flashers and turn signals; Brake pressure; Lamp/high beam indication; Engine Block Heater.

Caution warnings:

Parking brake; Coolant temperature; Hydraulic oil temperature; Transmission oil temperature; Air filter; Transmission filter; Hydraulic filter; Alternator; Low fuel.

Critical warnings:

Engine oil pressure; Brake pressure; Steering pressure – w/ aux steering*; Coolant temperature; Hydraulic oil temperature; Transmission oil temperature.

Backup alarm

Maintenance reminders:

Cab air filter; Engine oil filter; Fuel pre-filter; DEF tank vent filter; SCR supply filter; Hydraulic oil and filter; Engine air filter; Engine coolant; Drive belt; Cab recirculation filter; Engine breather filter; Transmission breather; Front and rear axle fluid; SCR supply module filter.

NOTE: *If equipped w/ option.

OPERATING WEIGHT

Z-Bar
Unit equipped w/ 23.5-R25 L3 Radial tires;
ROPS cab w/ heater and A/C; Heavy-duty
counterweight – 4,940 lb (2 241 kg); Heavy-duty
batteries; Front and rear fenders; Lights; Full
fuel; 165 lb (75 kg) operator; 4.25 yd³ (3.2 m³)
MD pin on w/ bolt on edge:
40,057 lb (18 170 kg)

XR
Unit equipped w/ 23.5-R25 L3 Radial tires;
ROPS cab w/ heater and A/C; Heavy-duty
counterweight – 4,940 lb (2 240 kg); Heavy-duty
batteries; Front and rear fenders; Lights; Full
fuel; 165 lb (75 kg) operator; 4.25 yd³ (3.2 m³)
MD pin on w/ bolt on edge:
40,648 lb (18 438 kg)

HYDRAULICS

Main pump – steering/implement:
Closed center pressure/flow compensated

Tandem variable displacement – load-sensing:
Max rated flow x2: 31.6 gpm @ 2000 RPM
(120 L/min @ 2000 RPM)

Loader control valve:
Closed-center, sectional 2, 3 or 4-function
w/ control for lift, tilt and auxiliary hydraulics

Loader auxiliary steering:
Hydraulic orbital center-pivot articulating
w/ on-demand oil flow

High pressure standby:
Implement 3,625 psi (25 000 kPa)
Steering 3,500 psi (24 132 kPa)

Filtration:
Filtered vent w/ relief on hydraulic reservoir,
maintains 3-5 psi on reservoir, 10-micron, return
filter furnishes only clean oil to all components
of the system

SERVICE CAPACITIES

Fuel tank	76.0 gal (288.0 L)
DEF tank – Diesel Exhaust Fluid:	
Usable	9.8 gal (37.1 L)
Total	15.6 gal (58.9 L)
Hydraulic system:	
Reservoir	24.0 gal (90.8 L)
Total	47.0 gal (178.0 L)
Transmission:	
Service w/ filter	36.0 qt (34.1 L)
Front and rear axle:	
Front axle	42.3 qt (40.0 L)
Rear axle	42.3 qt (40.0 L)
Engine oil w/ filter	16.0 qt (15.1 L)
Cooling system	32.0 qt (30.0 L)

OTHER SPECIFICATIONS

Lift cylinder:
Bore diameter 5.5 in (139.7 mm)
Rod diameter 3.0 in (76.2 mm)
Stroke 33.3 in (845.7 mm)

Dump cylinder:
Bore diameter 6.5 in (165.1 mm)
Rod diameter 3.5 in (88.9 mm)
Stroke 23.6 in (599.6 mm)

Loader:
Z-Bar loader linkage; Single control for
lift and tilt; Positive hold float; Automatic
return-to-dig; Automatic height control;
Automatic return-to-travel; Brake pedal
transmission disconnect; Bucket position
indicator on bucket.

Cycle time:
Raise w/ rated bucket load 6.2 sec
Dump w/ rated bucket load 1.2 sec
Float down 2.5 sec

Sound level in Cab (LpA) 68 dB(A)

Exterior sound level (LwA) 104 dB(A)

NOTE: Sound level data tested in accordance
with ISO6395, 6396, 3744.

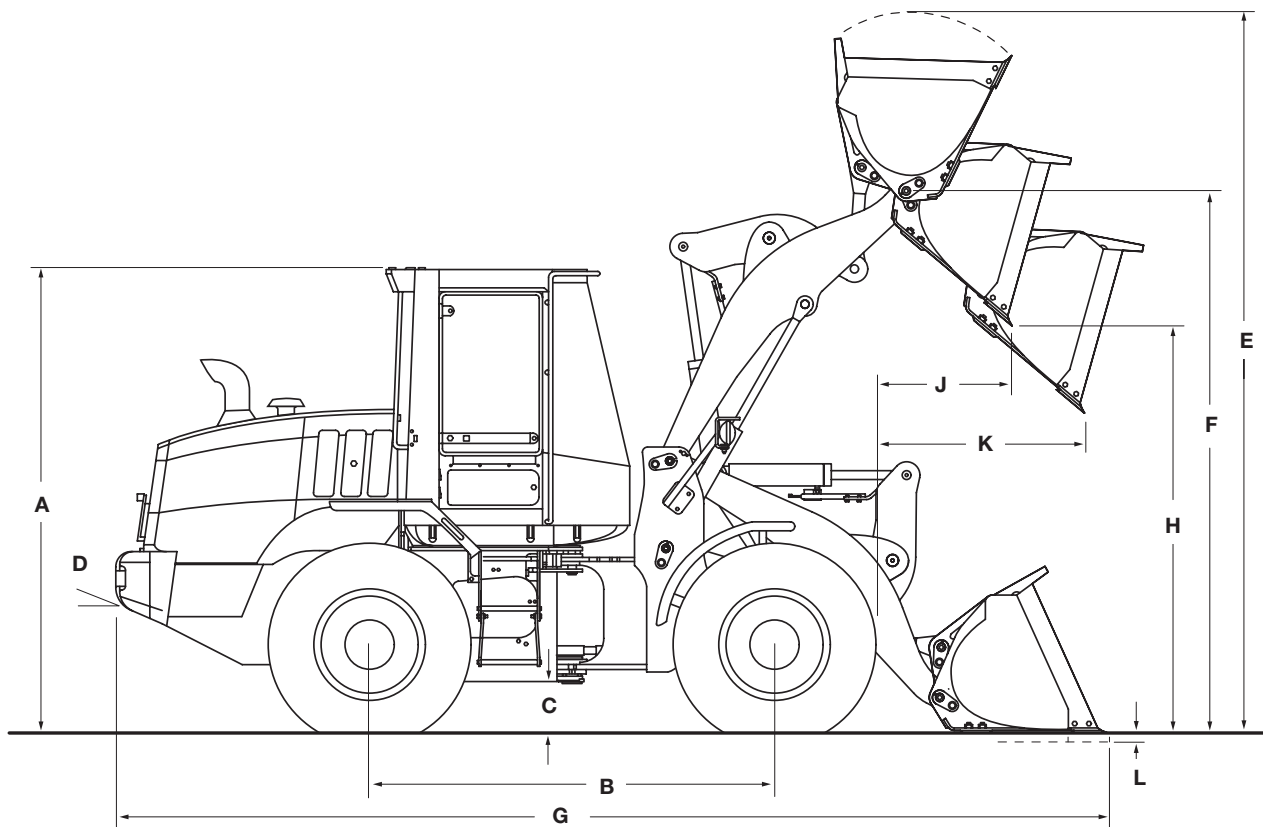

Line drawings are for illustrative purpose only and may not be exact representation of unit.

DIMENSIONS

A. Height to top of ROPS cab	136.2 in (3 460 mm)
Height to drawbar	42.6 in (1 081 mm)
B. Wheelbase	131.5 in (3 340 mm)
C. Ground clearance	17.0 in (431 mm)
D. Angle of departure	29°
Width:	
Overall* without bucket	111.4 in (2 829 mm)
Tread width	87.8 in (2 230 mm)
Turning radius* – outside	236.3 in (6 003 mm)
Turning angle:	
From center	40°
Total angle	80°
Rear axle oscillation – total	24°

NOTE: *Dimensions taken with 23.5-R25 L3 Radial tires. Additional dimensions on pages 4 through 8.

WEIGHT ADJUSTMENTS

Select Options	Weight Adjustment	Tipping Load Adjustment Straight: Deflected*	Tipping Load Adjustment 40° Turn: Deflected*
23.5-R25 L2 Bias	-748 lb (-339 kg)	-610 lb (-277 kg)	-971 lb (-440 kg)
23.5-R25 L2 Radial tires	-28 lb (-13 kg)	-104 lb (-47 kg)	-133 lb (-60 kg)
23.5-R25 Snow Radial Tires	+52 lb (+24 kg)	+162 lb (+73 kg)	+166 lb (+75 kg)

NOTE: Unit equipped with Z-Bar loader arms, 4.25 yd³ (3.2 m³) general purpose pin on bucket with bolt-on edge, 23.5-R25 L3 Radial tires, ROPS cab with heater and air conditioner, heavy counterweight, heavy-duty batteries, front and rear fenders, full fuel and 165 lb (75 kg) operator. Adjust select options from rated weight.
*Tipping loads: ISO 14397-1 Deflected Tires.

PERFORMANCE SPECS

821G Z-Bar*		4.5 yd³ (3.4 m³) Bucket with Bolt-on Edge - Pin On	4.25 yd³ (3.2 m³) Bucket with Bolt-on Edge - Pin On	4.0 yd³ (3.1 m³) Bucket with Teeth - Pin On
Operating weight		40,123 lb (18 200 kg)	40,057 lb (18 170 kg)	39,916 lb (18 106 kg)
E.	Operating height – fully raised with spillguard	216.7 in (5 505 mm)	215.4 in (5 471 mm)	215.4 in (5 471 mm)
F.	Hinge pin height – fully raised	162.2 in (4 120 mm)	162.2 in (4 120 mm)	162.2 in (4 120 mm)
G.	Overall length – bucket level on ground	316.5 in (8 039 mm)	315.1 in (8 004 mm)	321.0 in (8 153 mm)
Dump angle – fully raised		55°	55°	55°
H.	Dump height – fully raised, 45° dump	116.5 in (2 958 mm)	117.3 in (2 981 mm)	113.6 in (2 885 mm)
J.	Bucket reach – fully raised, 45° dump	44.4 in (1 128 mm)	43.4 in (1 102 mm)	47.8 in (1 215 mm)
K.	Bucket reach – 7 ft 0 in (2.13 m) height, 45° dump	67.4 in (1 712 mm)	66.8 in (1 696 mm)	69.4 in (1 762 mm)
L.	Dig depth	3.1 in (78 mm)	3.1 in (78 mm)	3.1 in (78 mm)
Operating load – ISO Rigid Tires		13,342 lb (6 052 kg)	13,409 lb (6 082 kg)	13,625 lb (6 180 kg)
Operating load – ISO Deflected Tires		12,189 lb (5 529 kg)	12,257 lb (5 560 kg)	12,457 lb (5 650 kg)
Maximum material density – ISO Rigid Tires		2,965 lb/yd ³ (1 759 kg/m ³)	3,155 lb/yd ³ (1 872 kg/m ³)	3,406 lb/yd ³ (2 021 kg/m ³)
Maximum material density – ISO Deflected Tires		2,709 lb/yd ³ (1 607 kg/m ³)	2,884 lb/yd ³ (1 711 kg/m ³)	3,114 lb/yd ³ (1 848 kg/m ³)
Tipping load – ISO Rigid Tires:				
	Straight	32,245 lb (14 626 kg)	32,384 lb (14 689 kg)	32,870 lb (14 910 kg)
	40° turn	26,684 lb (12 104 kg)	26,819 lb (12 165 kg)	27,249 lb (12 360 kg)
Tipping load – ISO Deflected Tires:				
	Straight	30,231 lb (13 713 kg)	30,375 lb (13 777 kg)	30,829 lb (13 984 kg)
	40° turn	24,377 lb (11 057 kg)	24,515 lb (11 120 kg)	24,913 lb (11 300 kg)
Lift capacity:				
	Full height	21,913 lb (9 939 kg)	21,980 lb (9 970 kg)	22,138 lb (10 042 kg)
	Ground	40,294 lb (18 277 kg)	40,434 lb (18 341 kg)	40,760 lb (18 488 kg)
Breakout force with tilt cylinder		34,301 lb (15 559 kg)	35,288 lb (16 007 kg)	37,922 lb (17 201 kg)
Loader clearance circle with bucket		524.0 in (13 311 mm)	523.3 in (13 291 mm)	526.5 in (13 373 mm)

821G XR		4.5 yd³ (3.4 m³) Bucket with Bolt-on Edge - Pin On	4.25 yd³ (3.2 m³) Bucket with Bolt-on Edge - Pin On	4.0 yd³ (3.1 m³) Bucket with Teeth - Pin On
Operating weight		40,714 lb (18 467 kg)	40,648 lb (18 438 kg)	40,507 lb (18 373 kg)
E.	Operating height – fully raised with spillguard	234.1 in (5 946 mm)	232.8 in (5 912 mm)	232.8 in (5 912 mm)
F.	Hinge pin height – fully raised	179.6 in (4 561 mm)	179.6 in (4 561 mm)	179.6 in (4 561 mm)
G.	Overall length – bucket level on ground	335.6 in (8 525 mm)	334.3 in (8 490 mm)	340.1 in (8 638 mm)
Dump angle – fully raised		49°	49°	49°
H.	Dump height – fully raised, 45° dump	133.8 in (3 399 mm)	134.7 in (3 422 mm)	130.9 in (3 326 mm)
J.	Bucket reach – fully raised, 45° dump	48.9 in (1 241 mm)	47.8 in (1 215 mm)	52.3 in (1 327 mm)
K.	Bucket reach – 7 ft 0 in (2.13 m) height, 45° dump	84.6 in (2 150 mm)	84.0 in (2 132 mm)	86.8 in (2 205 mm)
L.	Dig depth	5.7 in (145 mm)	5.7 in (145 mm)	5.7 in (145 mm)
Operating load – ISO Rigid Tires		10,620 lb (4 817 kg)	10,678 lb (4 843 kg)	10,850 lb (4 922 kg)
Operating load – ISO Deflected Tires		9,803 lb (4 446 kg)	9,861 lb (4,473 kg)	10,024 lb (4 547 kg)
Maximum material density – ISO Rigid Tires		2,360 lb/yd ³ (1 400 kg/m ³)	2,512 lb/yd ³ (1 491 kg/m ³)	2,713 lb/yd ³ (1 610 kg/m ³)
Maximum material density – ISO Deflected Tires		2,178 lb/yd ³ (1 293 kg/m ³)	2,320 lb/yd ³ (1 377 kg/m ³)	2,506 lb/yd ³ (1 487 kg/m ³)
Tipping load – ISO Rigid Tires:				
	Straight	25,750 lb (11 680 kg)	25,870 lb (11 735 kg)	26,253 lb (11 908 kg)
	40° turn	21,239 lb (9 634 kg)	21,355 lb (9 687 kg)	21,701 lb (9 843 kg)
Tipping load – ISO Deflected Tires:				
	Straight	24,386 lb (11 061 kg)	24,508 lb (11 117 kg)	24,874 lb (11 283 kg)
	40° turn	19,605 lb (8 893 kg)	19,723 lb (8 946 kg)	20,049 lb (9 094 kg)
Lift capacity:				
	Full height	20,079 lb (9 108 kg)	20,146 lb (9 138 kg)	20,302 lb (9 209 kg)
	Ground	30,646 lb (13 901 kg)	30,790 lb (13 966 kg)	31,106 lb (14 110 kg)
Breakout force with tilt cylinder		34,876 lb (15 820 kg)	35,879 lb (16 275 kg)	38,553 lb (17 488 kg)
Loader clearance circle with bucket		543.4 in (13 804 mm)	542.5 in (13 780 mm)	546.4 in (13 879 mm)

821G		Z-Bar/XR	Z-Bar/XR	Z-Bar/XR
Maximum rollback:				
	Ground	41°/37°	41°/37°	42°/37°
	Carry position	45°/43°	45°/43°	45°/43°
	@ Full height	59°/60°	59°/60°	59°/60°
Maximum grading angle with bucket – back dragging		60°/63°	60°/63°	61°/64°
SAE bucket capacity – struck		3.78 yd ³ (2.89 m ³)	3.63 yd ³ (2.78 m ³)	3.44 yd ³ (2.63 m ³)
Heaped		4.50 yd ³ (3.44 m ³)	4.25 yd ³ (3.25 m ³)	4.00 yd ³ (3.06 m ³)
Bucket width – outside		119.3 in (3 030 mm)	119.3 in (3 030 mm)	119.2 in (3 027 mm)
Bucket weight		3,464 lb (1 571 kg)	3,398 lb (1 541 kg)	3,256 lb (1 477 kg)

PERFORMANCE SPECS

821G Z-Bar*		4.0 yd³ (3.06 m³) Bucket with Bolt-on Edge - JRB Coupler	3.8 yd³ (2.9 m³) Bucket with Teeth - JRB Coupler	4.0 yd³ (3.1 m³) Bucket with Bolt-On Edge - ACS Coupler
Operating weight		41,430 lb (18 792 kg)	41,289 lb (18 728 kg)	41,483 lb (18 816 kg)
E.	Operating height – fully raised with spillguard	221.9 in (5 636 mm)	221.9 in (5 637 mm)	218.8 in (5 558 mm)
F.	Hinge pin height – fully raised	162.1 in (4 118 mm)	162.1 in (4 118 mm)	162.1 in (4 118 mm)
G.	Overall length – bucket level on ground	325.1 in (8 258 mm)	331.0 in (8 406 mm)	320.9 in (8 151 mm)
Dump angle – fully raised		55°	55°	55°
H.	Dump height – fully raised, 45° dump	110.9 in (2 817 mm)	107.1 in (2 721 mm)	113.6 in (2 886 mm)
J.	Bucket reach – fully raised, 45° dump	51.0 in (1 295 mm)	55.4 in (1 408 mm)	47.8 in (1 213 mm)
K.	Bucket reach – 7 ft 0 in (2.13 m) height, 45° dump	71.2 in (1 807 mm)	73.5 in (1 866 mm)	69.4 in (1 762 mm)
L.	Dig depth	3.1 in (79 mm)	3.2 in (80 mm)	3.1 in (79 mm)
Operating load – ISO Rigid Tires		11,830 lb (5 366 kg)	12,023 lb (5 454 kg)	12,170 lb (5 520 kg)
Operating load – ISO Deflected Tires		10,768 lb (4 884 kg)	10,947 lb (4 966 kg)	11,077 lb (5 024 kg)
Maximum material density – ISO Rigid Tires		2,958 lb/yd ³ (1 755 kg/m ³)	3,164 lb/yd ³ (1 877 kg/m ³)	3,042 lb/yd ³ (1 805 kg/m ³)
Maximum material density – ISO Deflected Tires		2,692 lb/yd ³ (1 597 kg/m ³)	2,881 lb/yd ³ (1 709 kg/m ³)	2,769 lb/yd ³ (1 643 kg/m ³)
Tipping load – ISO Rigid Tires:				
	Straight	28,844 lb (13 083 kg)	29,278 lb (13 280 kg)	29,661 lb (13 454 kg)
	40° turn	23,661 lb (10 732 kg)	24,046 lb (10 907 kg)	24,339 lb (11 040 kg)
Tipping load – ISO Deflected Tires:				
	Straight	27,004 lb (12 249 kg)	27,412 lb (12 434 kg)	27,762 lb (12 593 kg)
	40° turn	21,537 lb (9 769 kg)	21,894 lb (9 931 kg)	22,154 lb (10 049 kg)
Lift capacity:				
	Full height	20,513 lb (9 305 kg)	20,670 lb (9 376 kg)	20,500 lb (9 299 kg)
	Ground	28,363 lb (12 865 kg)	29,604 lb (13 428 kg)	32,373 lb (14 684 kg)
Breakout force with tilt cylinder		28,872 lb (13 096 kg)	30,698 lb (13 925 kg)	31,163 lb (14 135 kg)
Loader clearance circle with bucket		529.0 in (13 437 mm)	532.4 in (13 523 mm)	526.5 in (13 374 mm)

821G XR		4.0 yd³ (3.06 m³) Bucket with Bolt-on Edge - JRB Coupler	3.8 yd³ (2.9 m³) Bucket with Teeth - JRB Coupler	4.0 yd³ (3.1 m³) Bucket with Bolt-On Edge - ACS Coupler
Operating weight		42,021 lb (19 060 kg)	41,879 lb (18 996 kg)	42,074 lb (19 084 kg)
E.	Operating height – fully raised with spillguard	239.3 in (6 078 mm)	239.3 in (6 078 mm)	236.2 in (5 999 mm)
F.	Hinge pin height – fully raised	179.5 in (4 559 mm)	179.5 in (4 559 mm)	179.5 in (4 559 mm)
G.	Overall length – bucket level on ground	344.2 in (8 743 mm)	350.1 in (8 892 mm)	340.0 in (8 636 mm)
Dump angle – fully raised		49°	49°	49°
H.	Dump height – fully raised, 45° dump	128.3 in (3 258 mm)	124.5 in (3 162 mm)	131.0 in (3 327 mm)
J.	Bucket reach – fully raised, 45° dump	55.4 in (1 408 mm)	59.9 in (1 521 mm)	52.2 in (1 326 mm)
K.	Bucket reach – 7 ft 0 in (2.13 m) height, 45° dump	88.8 in (2 256 mm)	91.4 in (2 322 mm)	86.8 in (2 204 mm)
L.	Dig depth	5.8 in (146 mm)	5.8 in (147 mm)	5.8 in (146 mm)
Operating load – ISO Rigid Tires		9,382 lb (4 256 kg)	9,540 lb (4 327 kg)	9,613 lb (4 361 kg)
Operating load – ISO Deflected Tires		8,622 lb (3 911 kg)	8,771 lb (3 978 kg)	8,833 lb (4 007 kg)
Maximum material density – ISO Rigid Tires		2,346 lb/yd ³ (1 392 kg/m ³)	2,510 lb/yd ³ (1 490 kg/m ³)	2,403 lb/yd ³ (1 426 kg/m ³)
Maximum material density – ISO Deflected Tires		2,155 lb/yd ³ (1 279 kg/m ³)	2,308 lb/yd ³ (1 370 kg/m ³)	2,208 lb/yd ³ (1 310 kg/m ³)
Tipping load – ISO Rigid Tires:				
	Straight	23,007 lb (10 436 kg)	23,356 lb (10 594 kg)	23,569 lb (10 691 kg)
	40° turn	18,764 lb (8 511 kg)	19,079 lb (8 654 kg)	19,227 lb (8 721 kg)
Tipping load – ISO Deflected Tires:				
	Straight	21,745 lb (9 863 kg)	22,078 lb (10 015 kg)	22,272 lb (10 102 kg)
	40° turn	17,244 lb (7 822 kg)	17,541 lb (7 957 kg)	17,667 lb (8 013 kg)
Lift capacity:				
	Full height	18,692 lb (8 479 kg)	18,847 lb (8 549 kg)	18,674 lb (8 470 kg)
	Ground	28,087 lb (12 740 kg)	28,385 lb (12 875 kg)	28,592 lb (12 969 kg)
Breakout force with tilt cylinder		29,366 lb (13 320 kg)	31,221 lb (14 161 kg)	31,694 lb (14 376 kg)
Loader clearance circle with bucket		549.4 in (13 955 mm)	553.5 in (14 059 mm)	546.4 in (13 880 mm)

821G		Z-Bar/XR	Z-Bar/XR	Z-Bar/XR
Maximum rollback:	Ground	42°/37°	42°/37°	42°/37°
	Carry position	45°/43°	45°/43°	45°/43°
	@ Full height	59°/60°	59°/60°	59°/60°
Maximum grading angle with bucket – back dragging		62°/65°	64°/67°	61°/64°
SAE bucket capacity – struck		3.41 yd ³ (2.61 m ³)	3.25 yd ³ (2.48 m ³)	3.41 yd ³ (2.61 m ³)
Heaped		4.00 yd ³ (3.06 m ³)	3.80 yd ³ (2.91 m ³)	4.00 yd ³ (3.06 m ³)
Bucket width – outside		119.3 in (3 030 mm)	119.2 in (3 027 mm)	119.3 in (3 030 mm)
Bucket weight		4,770 lb (2 164 kg)	4,629 lb (2 100 kg)	4,824 lb (2 188 kg)

NOTE: *Z-Bar performance data shown with full counterweight.
Performance data unit equipped with 23.5-R25 L3 Radial tires, ROPS cab with heater and air conditioner, full counterweight, standard batteries, front and rear fenders, full fuel and 165 lb (75 kg) operator. Specifications per SAE J732, J1234, J695, J742, and J818.

STANDARD EQUIPMENT

OPERATOR ENVIRONMENT

See page 1

ENGINE

CASE/FPT F4HFE613S
Tier 4 Final Certified
Selective Catalytic Reduction (SCR) with Diesel Oxidation Catalyst
Selectable work modes:
Maximum Mode
Smart Mode
Turbocharger
Charge air cooling
Automatic belt tensioner
Integral engine oil cooling
Fuel filter with water trap
Dual-element dry-type air cleaner
Hydraulic-driven cooling fan
Air-cooled radiator
Mid-mounted cooling module with hydraulically driven auto reversing fan
Engine block heater
Common rail electronic fuel injection

LOADER

See page 2 – Operating weight,
Other specifications

DRIVETRAIN

4-wheel drive
4F/3R Selectable autoshift/manual shift transmission
Electronic Control Module – programmable, computer controlled proportional shifting with programmable gear selection
Onboard diagnostics
Single lever electronic shift control
F/N/R switch in loader control handle
Downshift button
Torque converter
Limited-slip differentials
Outboard planetary axles
Transmission oil cooler
Brake pedal transmission disconnect – declutch
Hydraulic wet disc brakes
Spring-applied hydraulic release parking brake
Limp-Home Mode
Greaseable rear axle trunnion
3-piece rims

HYDRAULICS

Adjustable Electro-hydraulic - EH loader control with one auxiliary function and 3 configurable buttons
Adjustable EH settings:
Smooth
Moderate
Aggressive
Auxiliary Hydraulics
Ride Control™
Locking hydraulics for coupler
EH Parallel Lift
Low-effort steering
Hydraulic driven cooling fan
Diagnostic quick couplers
Split flange hydraulic connections – 1 in or greater
Hydraulic oil cooler

ELECTRICAL

Alternator and voltage regulator
Battery isolator/electrical disconnect
120 amp alternator
(2) 700 CCA 12-volt batteries
Electric starter
Lights:
Integrated 4-corner strobe
2 Front and 2 rear halogen flood lights
2 Front driving headlights – high/low beam with integrated turn signals
2 LED stop/tail lights with integrated turn signals
Key start/stop switch
Backup alarm
Centrally located fuse box with all electrical circuits protected
Remote jump start posts

OTHER

Electric hood lift
Front and rear fenders, partial coverage
External rear view mirrors
Heavy counterweight
Drawbar hitch
Articulation locking bar
Lift arm locking bar
Lift and tie-down points – front/rear
Rear frame side covers
License plate brackets; front bracket and lit rear bracket
Rubber steering stops
Grouped remote-mounted ecology drains:
Engine oil
Engine coolant
Hydraulic oil

TELEMATICS

CASE SiteWatch™ Telematics – includes hardware and a 3-yr Advanced data subscription
SiteConnect Module providing remote diagnostics capability

OPTIONAL EQUIPMENT

OPERATOR ENVIRONMENT

Cloth-covered heated air-suspension seat with headrest
Sound Shield noise suppression package
Bluetooth radio, 12V AM/FM with auxiliary input
Cab convenience package:
Rear sun shade, interior mirror, under the seat drawer, coat hook, 12V accessory port, and an ash tray
In cab powered cooler box
In cab accessory mount
Rear view camera
External heated rear view mirrors
Front LED driving/headlights
LED front and rear work lights – 4 front, 2 rear

DRIVETRAIN

5F/3R Autoshift/manual shift transmission, lockup torque converter, PowerInch de-clutch
Heavy-duty axles:
With locking front differential and open/conventional rear differential
Cold weather package:
Heavy-duty (2) 950 CCA 12V batteries
Fuel heater
Hydraulic oil cooler bypass
Low temperature hydraulic oil
Fast-warm hydraulic valve

HYDRAULICS

Secondary steering
Integrated Payload System
Tire Pressure Monitoring System
2-function loader valve with joystick loader control
4-function loader valve with joystick loader control and two proportional auxiliary roller switches

LOADER

XR extended reach version
Attachment auxiliary hydraulics
Coupler systems – JRB or ACS compatible
Buckets – see pages 4 through 6

TIRES

23.5 x 25 L2 bias – dirt/traction
23.5 x 25 L3 bias – rock
23.5-R25 L2 radial – dirt/traction
23.5-R25 L3 radial – rock
23.5-R25 radial Michelin SnoPlus
Axle oscillation stops

ADVANCED ENGINE AIR FILTRATION

Sy-Klone® ejector type pre-cleaner

OTHER

Additional RH steps and platform with standard or wide fenders
12.4 mph (20 kph) maximum speed control
Special paint
Skid plate and transmission
Standard fenders with right and left hand steps
Wide full coverage fenders with right and left hand steps

CaseCE.com

©2021 CNH Industrial America LLC. All rights reserved. CASE is a trademark registered in the United States and many other countries, owned by or licensed to CNH Industrial N.V., its subsidiaries or affiliates. CNH Industrial Capital is a trademark in the United States and many other countries, owned by or licensed to CNH Industrial N.V., its subsidiaries or affiliates. Printed in U.S.A. Contains 10% post-consumer fiber.

IMPORTANT: CASE Construction Equipment Inc. reserves the right to change these specifications without notice and without incurring any obligation relating to such change. Availability of some models and equipment builds vary according to the country in which the equipment is used. The illustrations and text may include optional equipment and accessories and may not include all standard equipment. Your CASE dealer/distributor will be able to give you details of the products and their specifications available in your area.



CASE Construction Equipment is biodiesel-friendly. NOTE: All engines meet current EPA emissions regulations. All specifications are stated in accordance with SAE Standards or Recommended Practices, where applicable.



Always read the Operator's Manual before operating any equipment. Inspect equipment before using it, and be sure it is operating properly. Follow the product safety signs and use any safety features provided.

Form No. CCE202104821G
Replaces Form No. CCE201910821G

821G

**City of Palmer
Resolution No. 23-015**

Subject: Authorize the City Manager to Advance \$583,482 from the General Fund Unassigned Fund Balance to the Water and Sewer Fund for the Insulation Repairs to Reservoir 4 Heavily Damaged in the January 2022 Windstorm

Agenda of: May 23, 2023

Council Action: **Approved** **Amended:** _____
 Defeated

Originator Information:

Originator: Jude Bilafer, Director of Public Works

Department Review:

Route to:	Department Director:	Signature:	Date:
_____	Community Development	_____	_____
_____	Finance	_____	_____
_____	Fire	_____	_____
_____	Police	_____	_____
X	Public Works	<i>JPB</i>	05/03/2023

Certification of Funds:

Total amount of funds listed in this legislation: \$ **583,482**

This legislation (√):

- Creates revenue in the amount of: \$ _____
- Creates expenditure in the amount of: \$ **583,482**
- Creates a saving in the amount of: \$ _____
- Has no fiscal impact

Funds are (√):

- Budgeted Line item(s): 02-01-10-6078 Transfers Out; 24-00-00-3673 Transfer from Other Fund
- Not budgeted 24-52-10-6226 Reservoir 4 Repairs

Director of Finance Signature: *[Signature]*

Approved for Presentation By:

	Signature:	Remarks:
City Manager	<u><i>[Signature]</i></u>	_____
City Attorney	_____	_____
City Clerk	_____	_____

Attachment(s):

1. Resolution No. 23-015

Summary Statement/Background:

In January 2022, a severe windstorm heavily damaged the exterior insulation of Reservoir 4, located on Trunk Road near the Mat-Su College. Disaster declarations were proclaimed at both the federal and state levels. Discussions with the Federal Emergency Management Agency (FEMA) and the City's insurance company began shortly after the disaster declarations were received and remain on-going. A damage assessment on reservoir 4 was completed in May of 2022. HDL engineering was hired to design the repairs for reservoir and to provide construction administration services during repairs. The insulation repair project bids were opened on 27 April 2023.

\$918,113 is the total cost for design services, construction administration, and the insulation repair project.

The City has received to date \$334,631 from the City's insurance company. Additional reimbursements from the insurance company will occur upon completion of the insulation repairs project. In the interim, the unassigned fund balance from the General Fund loaned to the Water and Sewer Fund will allow for the completion of this project and then the General Fund will be reimbursed by insurance.

Administration's Recommendation:

Approve Resolution No. 23-015.

LEGISLATIVE HISTORY

Introduced by: Manager Moosey

Date: May 23, 2023

Public Hearing:

Action:

Vote:

Yes:

No:

--	--

CITY OF PALMER, ALASKA

Resolution No. 23-015

A Resolution of the Palmer City Council Authorizing the City Manager to Advance \$583,482 from the General Fund Unassigned Fund Balance to the Water and Sewer Fund for the Insulation Repairs to Reservoir 4 Heavily Damaged in the January 2022 Windstorm

WHEREAS, the City of Palmer, Alaska (the "City") is a home rule city and under Section 11 of Article X of the Alaska Constitution may exercise all legislative power not prohibited by law or the charter of the City, and the City has determined that the matters set forth in this resolution are not prohibited by law or the charter; and

WHEREAS, the City of Palmer was impacted by a severe winter storm 1-4 January 2022; and

WHEREAS, the City's Reservoir 4 was heavily damaged during the 1-4 January 2022 windstorm; and

WHEREAS, it is necessary and in the best interest of the City and its residents that the City advance these funds from the General Fund Unassigned Fund Balance to the Water Sewer Fund for these repairs; and

WHEREAS, the City's Insurance will reimburse the cost of the repairs.

NOW, THEREFORE, BE IT RESOLVED, the Palmer City Council hereby appropriates funding from the General Fund Unassigned Fund Balance to the Water Sewer Fund for the Reservoir 4 Insulation Repairs Project in an amount not to exceed \$583,482.

Approved by the Palmer City Council this _____ day of _____, 2023.

Steve Carrington, Mayor

Shelly M. Acteson, CMC, City Clerk

**City of Palmer
Resolution No. 23-016**

Subject: Accepting and Appropriating Healthy & Equitable Communities Grant Funds from the State of Alaska, Department of Health and Social Services, and Division of Public Health in the Amount of \$89,078 to Provide Funding to Alaskan Local Governments in Support of Creating and Sustaining Healthy and Equitable Communities Around the State

Agenda of: May 23, 2023

Council Action: **Approved** **Amended:** _____
 Defeated

Originator Information:

Originator: John Moosey, City Manager

Department Review:

Route to:	Department Director:	Signature:	Date:
_____	Community Development	_____	_____
_____	Finance	_____	_____
_____	Fire	_____	_____
_____	Police	_____	_____
_____	Public Works	_____	_____

Certification of Funds:

Total amount of funds listed in this legislation: \$ **89,078**

This legislation (√):

- Creates revenue in the amount of: \$ 89,078
- Creates expenditure in the amount of: \$ 89,078
- Creates a saving in the amount of: \$ _____
- Has no fiscal impact

Funds are (√):

- Budgeted Line item(s): _____
- Not budgeted 08-00-00-3988 State Grants 08-01-10-7185 HDSS HEC Grant Rd 2

Director of Finance Signature: 

Approved for Presentation By:

	Signature:	Remarks:
City Manager	<u></u>	_____
City Attorney	_____	_____
City Clerk	_____	_____

Attachment(s):

1. Resolution No. 23-016
2. Memorandum of Agreement

Summary Statement/Background:

The City of Palmer will act as a pass-through entity to Daybreak Incorporated so they can provide the services outlined in the attached MOA. This funding is the second round of the funding approved by Palmer City Council on 2/8/22. The Department of Public Health will be providing \$89,078 in Round 2 funds in accordance with the terms of the attached agreement. Round 1 funding provided was in the amount of \$42,080.80: for a cumulative total of \$131,158.80.

Administration's Recommendation:

Approve Resolution No. 23-016

LEGISLATIVE HISTORY

Introduced by:

Date:

Action:

Vote:

Yes:

No:

--	--

CITY OF PALMER, ALASKA

Resolution No. 23-016

A Resolution of the Palmer City Council Authorizing the City Manager to Accepting and Appropriating Healthy & Equitable Communities Grant Funds from the State of Alaska, Department of Health and Social Services, and Division of Public Health in the Amount of \$89,078 to Provide Funding to Alaskan Local Governments in Support of Creating and Sustaining Healthy and Equitable Communities Around the State

WHEREAS, the City of Palmer strives to serve well its residents and surrounding population; and

WHEREAS, the City of Palmer will partner with local organizations for the common good.

NOW, THEREFORE, BE IT RESOLVED by the Palmer City Council hereby to accept and appropriate Healthy & Equitable Communities Grant funds from the State of Alaska, Department of Health and Social Services, and Division of Public Health in the amount of \$89,078 to provide funding to Alaskan local governments in support of creating and sustaining Healthy and Equitable Communities around the State.

NOW, THEREFORE, BE IT FURTHER RESOLVED by the Palmer City Council hereby to authorize the City Manager to execute the grant as offered.

Approved by the Palmer City Council this ____ day of _____, 2023.

Steven J Carrington, Mayor

Shelly Acteson, CMC, City Clerk



John Moosey
City Manager

City of Palmer
231 W. Evergreen Ave.
Palmer, Alaska 99645-6952
(907) 761-1317
E-mail: jmoosey@palmerak.org
www.palmerak.org

MEMORANDUM OF AGREEMENT BETWEEN THE CITY OF PALMER AND DAYBREAK INCORPORATED

This Memorandum of Agreement (MOA) is entered into by and between the City of Palmer, Alaska (hereinafter referred to as "City") and Daybreak Incorporated (hereinafter referred to as "Daybreak").

I. PURPOSE

The purpose of this MOA is to establish terms and conditions under which Daybreak and the City will collaborate to improve health outcomes for underserved Palmer residents, specifically targeting those struggling with homelessness, mental health and substance use disorders, and access to health insurance and public assistance.

Funding will support the following activities and strategies to promote and build a healthy and equitable community.

1. Increased access to health insurance, mental health services, and substance use disorder treatment for targeted populations.
2. Improved community understanding of mental health and homelessness issues.
3. Provision of essential resources, including State identification cards, track phones, hygiene kits, and other essential items, to at least 100 high-risk individuals over the course of 12 months.
4. Enhanced skillsets and employment readiness among individuals and families participating in the back-to-work training.
5. Established a community case manager position and supportive infrastructure leading to improved health outcomes for Palmer residents.
6. Developed local emergency response plan informed by local advisory groups consisting of representatives from high-risk underserved populations.
7. Increased collaboration with local health and non-health agencies leading to improved overall health outcomes for high-risk, underserved Palmer residents.

II. RESPONSIBILITIES OF THE CITY

The City agrees to:

1. Collaborate with Daybreak and support its efforts to improve health outcomes in the community.
2. Facilitate access to public resources and services as needed to support the project.
3. Support Daybreak in its outreach activities by promoting community understanding of mental health and homelessness issues.
4. Share relevant data with Daybreak to aid in the collection of project progress and outcomes.
5. Serve as the pass-through agency for grant funds in the amount of \$89,078 from The State of Alaska, Department of Health, Division of Public Health in accordance with the terms of this agreement.

III. RESPONSIBILITIES OF DAYBREAK

Daybreak agrees to:

1. Employ a dedicated community case manager to facilitate access to health insurance, mental health services, and substance use disorder treatment.
2. Conduct outreach activities to raise community awareness and understanding of mental health and homelessness issues.
3. Provide essential resources to underserved individuals in Palmer.
4. Collaborate with local health and non-health agencies to implement strategies that improve overall health outcomes.
5. Collect data and report on project progress and outcomes to the City.

Invoicing:

Daybreak will submit quarterly invoices detailing services performed. Quarterly invoices should be supported with completed reporting templates and any applicable backup documentation such as receipts, payroll information, etc. Invoices are due January 5, April 5, July 5, and October 5 for each quarter.

The invoice must:

- Reference Daybreak's name, address, and phone number
- Reference the contract number: C0622-584-P
- Include the invoice number
- Reference the Alaska Division of Public Health – Healthy & Equitable Communities MOA

Failure to include the required information on invoices may cause an unavoidable delay to the payment process. The State will pay all invoices within thirty (30) days of invoice

approval by the project director. The recipient shall submit final invoices no later than 30 days after the MOA expires.

Budget:

The budget for this MOA will be substantially the same as listed below.

- \$1,500 for state identification.
- \$4,700 for track phones.
- \$1,200 for shower & laundry vouchers.
- \$1,000 for hygiene kits.
- \$10,000 for back-to-work training classes and materials.
- \$48,000 for a full-time community case manager.
- \$9,000 for case manager supervision.
- \$12,000 for office space rent.
- \$1,600 for office supplies and equipment.

The total proposed budget is approximately \$88,000. This investment will serve as a catalyst for change in our community, bridging gaps between services and the individuals who need them most, thereby improving health outcomes and quality of life for our underserved residents.

Reporting:

Reporting requirements will be due at the same time as invoices. Payment will not be issued unless necessary reporting is attached. A template for the reporting is attached to this MOA.

Any future reporting requirements requested by the State of Alaska will be honored by Daybreak Incorporated.

IV. TERM OF AGREEMENT

This MOA shall be effective upon the signature of the City and Daybreak authorized officials. It shall be in force for a period of one year from the effective date. This MOA may be modified or amended as necessary by mutual consent of both parties, in writing. Both parties agree to communicate timely and effectively as needed to support the goals of this agreement.

V. INDEMNIFICATION

Daybreak shall defend, indemnify, and hold harmless City and its officers, directors, employees, agents, successors, and permitted from and against all Losses arising out of or resulting from any third-party claim, suit, action, or proceeding including attorney fees, arising out of or resulting from: (1) bodily injury, death of any person, or damage to real or tangible, personal property resulting from the willful, fraudulent, or negligent acts or

omissions of Daybreak or Daybreak Personnel; and (2) Daybreak's breach of any representation, warranty, or obligation of Daybreak set forth in this Agreement.

VI. LIABILITY

All liability insurance related to Daybreak, Incorporated will be the responsibility of Daybreak Incorporated. The City of Palmer does not accept liability for Daybreak employees, nor has any supervisory responsibility of Daybreak employees. Daybreak will maintain or exceed its current levels of commercial and professional liability insurance during the course of this Agreement. Upon request by the City, Daybreak will provide proof of certificate(s) of insurance.

VII. TERMINATION

Either party upon 30 days written notice to the other party may terminate this MOA.

VIII. CONTACT PERSONS

The contact person for each organization is as follows:

For the City:

Primary Point of Contact
Kristin Elieff
Administrative Assistant to the City Manager
kelieff@palmerak.org
907.761.1317

Financial Point of Contact
Gina Davis
Finance Director
gdavis@palmerak.org
907.761.1314

Other (signatory)
John Moosey
City Manager
jmoosey@palmerak.org
907.761.1304

For Daybreak:

Polly-Beth Odom
Executive Director
pollybeth@daybreakmhsc.com
907.745.6012

SIGNATURES

In witness whereof, the parties hereto have executed this MOA as of the last date written below.

For the City of Palmer, Alaska:

John Moosey
City Manager

Date _____

For Daybreak Incorporated:

Polly-Beth Odom
Executive Director

Date _____

DRAFT



**Healthy & Equitable Communities
Memorandum of Agreement (MOA), Between
State of Alaska – Department of Health
Division of Public Health (DPH)
- and -
City of Palmer
MOA # C0622-584-P
Amendment 1**

AMENDMENT 1

This amendment serves to:

- Extend the period of performance by one year, through May 31, 2024.
- Adds \$89,078 in funding to support the year 2 activities described in the attached Round 2 Application.

I. PURPOSE AND SCOPE

The State of Alaska, Dept of Health, Division of Public Health will provide funding to Alaskan local governments in support of creating and sustaining healthy and equitable communities around the state. This project is funded through two federal grants equally (50%/50% split) with ALN/CFDA codes 93.391 and 93.268.

Funding will support the following activities and strategies to promote and build healthy & equitable communities around the state. All funded activities must have an emphasis on high risk, underserved population groups.

- Ensure a fair and adequate baseline of care is established for populations at higher risk that are underserved and who are disproportionately impacted by COVID-19 by expanding existing or developing new mitigation and prevention resources and services;
- Increase/improve data collection and reporting for populations disproportionately affected by COVID-19 to guide current and future pandemic response;
- Build, leverage or expand infrastructure support for COVID-19 or future pandemic prevention and control among populations that are at higher risk or underserved;
- Mobilize partners to build and promote healthy and equitable communities, improving everyone's opportunities for living a healthy life, particularly those who are disproportionately impacted by COVID-19;
- Improve access to COVID-19 vaccine, as well as other necessary vaccines, for individuals who are higher risk or underserved.

II. THE STATE OF ALASKA DIVISION OF PUBLIC HEALTH (DPH) AGREES TO:

Provide support to the community for COVID-19 response and mitigation activities. The Healthy & Equitable Communities Project Team is available to consult and provide technical assistance to government entities for health equity funds and to pre-approve pass-through recipients of award funding. The team will also ensure that approved activities meet the funding requirements.

DPH agrees to provide \$89,078 in Round 2 funds in accordance with the terms of this agreement. Round 1 funding provided was in the amount of \$42,080.80; for a cumulative total of \$131,158.80.

III. CITY OF PALMER AGREES TO:

Conduct the services as described in the attached application and proposal response following the last page of this MOA.

Invoicing

The recipient will submit quarterly invoices detailing services performed. Quarterly invoices should be supported with completed reporting templates and any applicable backup documentation such as receipts, payroll information, sub award agreements, etc. Invoices are due January 10, April 10, July 10, and October 10 for each quarter.

The invoice must:

- Reference the recipient’s name, address, and phone number
- Reference the contract number: C0622-584-P
- Include the City of Palmer’s invoice number
- Reference the Alaska Division of Public Health – Healthy & Equitable Communities MOA

Send invoices to: doh.publichealth@alaska.gov

(reference “C0622-584-P MOA Reimbursement Request” in the subject line)

Failure to include the required information on invoices may cause an unavoidable delay to the payment process. The State will pay all invoices within thirty (30) days of invoice approval by the project director. The recipient shall submit final invoices no later than 30 days after the MOA expires.

REPORTING:

Reporting requirements will be due at the same time as invoices. Payment will not be issued unless necessary reporting is attached. Reporting requirements will be determined during the MOA preparation and will be dependent upon the type of activities selected. Entities are encouraged to collaborate with hospitals, schools, and community organizations to improve the outcomes for their population.

Any projects that will be collecting data may have additional reporting requirements. Initial information about the project will be needed, including:

- Who is collecting data?
- Why is data being collected?
- What communities/populations are being researched?
- What type of data is being collected?
- Estimated timeframe of data collection
- How will this data be used?

IV. JOINT RESPONSIBILITIES:

Should there be a conflict amongst the documents, the following order of precedence shall apply: first, this agreement; second, the application; third, the proposal.

Both parties agree to communicate timely and effectively as needed to support the goals of this agreement. Points of contact for both parties are as follows:

State of Alaska – DPH:

Primary Points of Contact: Judy Holland, Project Director
Judy.Holland@alaska.gov
907/334-2669

Abigail Vanwormer, Community Coordinator
Abigail.vanwormer@alaska.gov
907/764-3890

Send invoices to: doh.publichealth@alaska.gov
(reference "C0622-584-P MOA Reimbursement Request" in the subject line)

City of Palmer:

Primary Point of Contact: Kristin Elieff
kelieff@palmerak.org
907/761-1317

Finance Point of Contact: Gina Davis
gdavis@palmerak.org
907/761-1314

Other (Signatory): John Moosey
jmoosey@palmerak.org
907/761-1304

V. **PERIOD OF AGREEMENT AND TERMINATION:**

This agreement will be in effect from the date of execution through May 31, 2024. The services may extend beyond that date by mutual agreement of both parties. Any extension provided will be for time only; no additional funds will be offered.

VI. **SIGNATURES:**

By signature of the below, both parties agree to the terms of this MOA.

BY: Judy Holland
Judy Holland, DOH Project Director

DATE: May 8, 2023

BY: _____
John Moosey, City of Palmer

DATE: _____

BY: _____
Christy Lawton, DPH Acting Director

DATE: _____

BY: _____
Matthew Meienberg, DOH Procurement Specialist

DATE: _____



Healthy & Equitable Communities Round 2 Funding for Cities and Boroughs – Application and Memorandum of Agreement Information

PURPOSE:

The State of Alaska, Department of Health, Division of Public Health will provide funding to Alaskan local governments in support of creating and sustaining healthy and equitable communities around the state.

Funding will be available through May 31, 2024 to support the following activities and strategies to promote and build healthy and equitable communities around the state. All funded activities must have an emphasis on high risk, underserved population groups.

- Ensure a fair and adequate baseline of care is established for populations at higher risk that are underserved and who are disproportionately impacted by COVID-19 by expanding existing or developing new mitigation and prevention resources and services;
- Increase/improve data collection and reporting for populations disproportionately affected by COVID-19 to guide current and future pandemic response;
- Build, leverage or expand infrastructure support for COVID-19 or future pandemic prevention and control among populations that are at higher risk or underserved;
- Mobilize partners to build and promote healthy and equitable communities, improving everyone's opportunities for living a healthy life, particularly those who are disproportionately impacted by COVID-19;
- Improve access to COVID-19 vaccine, as well as other necessary vaccines, for individuals who are higher risk or underserved.

SCOPE OF FUNDING:

Strategies that are implemented should aim to build infrastructures that both improve health outcomes for higher risk underserved Alaskans in the current COVID-19 pandemic and set the foundation for future responses. This application mentions several eligible activities, but communities are not limited in scope to these examples. There are several resources available for communities to assist them in determining what types of activities may be proposed. The [Alaska Health Equity Index](#) utilizes data from the US Census Bureau and the US Centers for Disease Control and Prevention's Social Vulnerability Index and is an excellent reference to assist communities in identifying target populations* and areas of need. The Healthy Alaskans team has identified priority health topics for the [Healthy Alaskans 2030 plan](#) including strategies and actionable objectives within each strategy. Both resources highlight the needs of Alaskans, and communities are encouraged to develop plans that incorporate factors from either of these resources.

*Target populations can include but are not limited to:

- Low income or homeless individuals
- Individuals/families/communities with limited access to technology/internet
- Individuals/families/communities who face food insecurity
- Communities with limited to no transportation access

- Individuals without access to health care
- Populations that do not speak English as their first language
- Rural communities/areas where physical services are not accessible
- Refugee/immigrant communities that face economic, cultural, or linguistic barriers to accessing health care services
- Individuals with disabilities
- Older adults
- Children
- Individuals with mental health or substance-related disorders

Funding is calculated using two factors: population size, and the [Alaska Health Equity Index](#).

ELIGIBILITY:

Local governments are eligible to apply and may propose plans to engage one or more communities and geographic areas. The definition of communities may also include a group of people who have particular characteristic in common (e.g. share similar cultural beliefs or interests). Please work with your local tribes, borough, or municipality to ensure efforts are coordinated. DHSS allows recipients to act as pass-through entities to provide funding to other recipients, including community-based organizations serving populations who may experience health inequities. **Technical assistance will be provided throughout the funding period to assist with reporting, advancing approved projects, pre-approval of activities and invoice processing.**

If you live in an unincorporated census area or census designated place, are aware of an entity or organization that is interested in implementing this work and unsure about how to access this funding opportunity, please contact Judy.Holland@alaska.gov or HECommunities@alaska.gov to discuss potential alternative opportunities. Designated entities must have the capacity to manage funds and implement projects within the scope of the funding. **If communities chose to pursue this route for funding, alternative entities must be identified by April 11, 2023.** The state intends to make available an alternate method of procurement for these entities, and the timeline for funding will be dependent upon the number of non-governmental entities identified across the state for this option. We will make every attempt to accommodate alternative requests. **For entities that chose to pursue this option, please be aware that the funding can take significantly longer to award through alternate procurement methods.**

REPORTING:

Reporting requirements will be due at the same time as invoices. Payment will not be issued unless necessary reporting is attached. Reporting requirements will be determined during the MOA preparation and will be dependent upon the type of activities selected. Entities are encouraged to collaborate with hospitals, schools and community organizations to improve the outcomes for their population.

Any projects that will be collecting data may have additional reporting requirements. Initial information about the project will be needed, including:

- Who is collecting data?
- Why is data being collected?
- What communities/populations are being researched?
- What type of data is being collected?
- Estimated timeframe of data collection
- How will this data be used?

PERIOD OF AGREEMENT, IMPORTANT DATES AND DEADLINES:

May, 2023 – May 31,2024	Period of Agreement
Wed. March 28, 10:00am	Member call via zoom hosted by Alaska Municipal League
Tuesday, April 25, by 5:00	Applications due to HECommunities@alaska.gov
May, 2023	Award funding to Communities via signed MOA
May 31, 2024	Final receipts due to DPH, payments issued to Communities

Submit questions to: Judy.Holland@alaska.gov or HECommunities@alaska.gov

TERMS OF PAYMENT: Funds will be reimbursed through invoicing upon approval of MOA. **Communities who do not apply for funding by April 25 will forfeit their allocation** and that funding will be reallocated at the State’s discretion. Communities wishing to propose projects larger than their allocated amounts can apply for this forfeited funding by contacting Judy Holland at Judy.Holland@alaska.gov or HECommunities@alaska.gov.

PRIOR APPROVAL REQUIRED*:

- Facility modifications
- Vehicles
- Furniture
- Equipment over \$25,000
- Reimbursement of pre-award costs (will only be considered back to June 1, 2021)

*If you wish to utilize funds for any of the above items, please provide a detailed description of how these items will fit into the overall goal of the project they will support and how they will be used.

FUNDS CANNOT BE USED FOR:

- Programs or services already funded by another HSS grant, contract or MOA
- Research
- Clinical care
- Land or buildings
- Publicity or propaganda

If these funds are used to administer COVID-19 testing or vaccine services recipients must:

- Establish/maintain a means to ensure that all positive COVID testing results performed by this entity/sub-recipient/pass through entity is reported to the State of Alaska Department of Health within 24 hours of administration.
- Establish/maintain a means to ensure that the COVID-19 vaccine administration performed by this entity/sub-recipient/pass through entity is reported to the State of Alaska Department of Health. All vaccinations must be reported within 24 hours of administration.

Please complete the following application to apply for this funding. Details from your application will be used to develop the MOA.

Submit completed application and W9 to: HECommunities@alaska.gov and cc Judy.Holland@alaska.gov.

Healthy and Equitable Communities Memorandum of Agreement Application

Primary Contact Information:

(Please make sure to include name, phone number, email and physical address for all contacts listed.)

Program Contact: Kristin Elieff

Phone number: 907-761-1317

Email: kelieff@palmerak.org

Physical Address: 231 W Evergreen Avenue Palmer, AK 99645

Finance Contact: Gina Davis

Phone number: 907-761-1314

Email: gdavis@palmerak.org

Physical Address: 231 W Evergreen Avenue Palmer, AK 99645

Other Contact that needs to sign/be listed on the Memorandum of Agreement (MOA):

Contact: John Moosey

Phone number: 907-761-1304

Email: jmoosey@palmerak.org

Physical Address: 231 W Evergreen Avenue Palmer, AK 99645

Please list communities and partners intended to be part of this funding, either through subawards or support.

Community/Partner Name(s):

Polly Beth Odom

pollybeth@daybreakmhsc.com

907-746-6019

550 South Alaska Street, Suite 202 Palmer, AK 99645

SCOPE and AMOUNTS:

Please check activities from the menu below. In the final box, indicate the dollar amount anticipated. **All activities selected must have an emphasis on high risk, underserved population groups.**

Menu of Activities

- 1. Ensure a fair and adequate baseline of care is established for populations who are disproportionately impacted by COVID-19 by expanding existing or developing new mitigation and prevention resources and services targeted at higher risk, underserved Alaskans:**
- Expand reach of case investigation and contact tracing
 - Enhance availability of supportive services that enable individuals to successfully isolate or quarantine
 - Collaborate with community groups who can connect people at higher risk for COVID 19 with community services
 - Improve access to vaccination information and services
 - Reduce the rate of preventable hospitalizations by improving access to primary and preventative care
 - Improve/increase access to health insurance
 - Provide new or improved access to mental health services or provide education for/destigmatize existing services
 - Provide/improve access to substance use disorder treatment/tobacco cessation resources or provide education for/destigmatize existing services
 - Adopt strategies in the built environment that can mitigate the impact of COVID-19, for example establishing new pedestrian zones to minimize crowding and encourage physical activity
 - Assess and adapt health policies, for example food service guidelines, to ensure they reach higher risk underserved Alaskans
 - Other activities (Please describe in the box below)

If there is not sufficient space to provide details of activities selected and proposed budget, please attach a spreadsheet or addendum to your application.

*****PLEASE SEE ATTACHED DOCUMENT*****

Total

- Depending on activities selected, reporting requirements may include some or all of the following measures:
- 1.1 Number of COVID-19 mitigation and prevention resources and services delivered in support of populations that are underserved and disproportionately affected.
 - 1.2 Number of COVID-19 tests completed by test type, results, and race and ethnicity
 - 1.3 Caseload, number of cases per case investigator, and number of contacts per contact tracer during the data collection period

2. Increase/improve data collection and reporting for populations disproportionately affected by COVID-19 to guide current and future pandemic response:

- Educate health care providers and community partners on the importance for collection of race, ethnicity, and other priority data elements
- Enhance the ability of electronic health records (EHR) systems to collect data on age, race, sex, and other differences among patients in health care systems
- Upgrade interoperability of health systems to comply with HL7 standards to report data elements including age, race, sex, and other priority data elements
- Provide training for staff on new/upgraded EHR systems
- Support staff who can enhance reporting of COVID-19 data to include race, ethnicity, sex, and other priority data elements
- Develop and disseminate data and other information materials to be culturally and linguistically appropriate for local audiences
- Other activities (Please describe in the box below)**

If there is not sufficient space to provide details of activities selected and proposed budget, please attach a spreadsheet or addendum to your application.

*****PLEASE SEE ATTACHED DOCUMENT*****

Total:

Depending on activities selected, reporting requirements may include the following measure:
2.1: Number of improvements to data collection, quality, and reporting capacity for recipients, partners and agencies related to disproportionate health impacts of COVID-19.

3. Build, leverage or expand infrastructure support for COVID-19 or future pandemic prevention and control with a focus on populations that are at higher risk and underserved:

- Establish or enhance local staffing or coalitions to that focus on improving COVID-19 or other health outcomes for these populations
- Develop or update local plans to improve health outcomes for higher risk underserved Alaskans
- Expand local capacity to offer targeted testing and contact tracing
- Improve local Continuity of Operations Plans (COOP) and exercises to prioritize higher risk underserved Alaskans
- Improve plans for use of community facilities to include better spaces for social distancing, isolation and quarantine
- Update plans for community shelter locations to ensure they are ADA compliant or can facilitate hosting health care pods including testing and vaccinations
- Increase/improve access to facilities/community spaces that promote health and physical activity and serve high-risk populations
- Provide training to local/regional public health or health workforce to better serve the needs of higher risk underserved Alaskans
- Hire health or public health workforce who are equipped to assess and address the needs of higher risk underserved Alaskans, for example trusted community members or community health workers
- Other activities (Please describe in the box below)

If there is not sufficient space to provide details of activities selected and proposed budget, please attach a spreadsheet or addendum to your application.

*****PLEASE SEE ATTACHED DOCUMENT*****

Total:

Depending on activities selected, reporting requirements may include the following measure:
3.1: Number of improvements to infrastructure to address disproportionate health impacts of COVID-19.

4. Mobilize partners to build and enhance community social supports targeted towards those who are disproportionately impacted by COVID-19:

- Tailor local testing, contact tracing, and quarantine practices and programs to be culturally or linguistically appropriate for targeted populations
- Develop and support local or regional advisory groups that have representation from higher risk underserved populations to inform emergency response activities**
- Build partnerships with local health and non health agencies (for example housing, transportation providers, food security, churches, community health workers, social workers) to implement strategies that decrease risk for COVID-19
- Develop and distribute COVID-19 prevention communication materials and messaging that are understood and resonate with local higher risk and underserved groups
- Identify and establish relationships with agencies who serve higher risk underserved groups to share information and improve access to services that prevent COVID-19
- Other activities (Please describe in the box below)

If there is not sufficient space to provide details of activities selected and proposed budget, please attach a spreadsheet or addendum to your application.

*****PLEASE SEE ATTACHED DOCUMENT*****

Total:

Depending on activities selected, reporting requirements may include the following measure:

4.1: Number and proportion of new, expanded, or existing partnerships mobilized to address disproportionate health impacts of COVID-19.

5. Improve access to COVID-19 vaccine, as well as other necessary vaccines, for individuals who are higher risk or underserved:

- Increase local health care capacity for providing vaccinations
- Hire additional staff to support administration of vaccines and to promote easily accessible health education
- Increase capacity for mobile vaccine delivery
- Increase the number of children, adolescents, and adults receiving all ACIP-recommended vaccines
- Other activities (Please describe in the box below)

If there is not sufficient space to provide details of activities selected and proposed budget, please attach a spreadsheet or addendum to your application.

*****PLEASE SEE ATTACHED DOCUMENT*****

Total:

Depending on activities selected, reporting requirements may include the following measure:

5.1: Provide a description of the work and successes/challenges of COVID-19 vaccine-related activities (e.g., number of vaccine clinics, number of mobile vaccine clinics, number of pop-up clinics).



BUILDING BRIDGES: HOLISTIC CARE FOR THE HOMELESS POPULATION IN PALMER, ALASKA

Kristin Elieff

CITY OF PALMER 231 W Evergreen Avenue Palmer, Alaska 99645

Contents

I. Executive Summary 2

II. Objectives..... 3

III. Strategies..... 4

IV. Expected Outcomes 5

V. Budget 6

I. Executive Summary

Daybreak Incorporated, a reputable non-profit organization established in 2000, has been diligently providing case management services to adults grappling with serious, chronic mental illnesses within the Palmer community. Over the past 23 years, Daybreak has identified a growing need for a dedicated community case manager position. This role is crucial to facilitate connections between our most vulnerable community members and the vital services and resources they need to improve their physical and behavioral health.

To address this rising need, Daybreak proposes a pilot project aimed at building infrastructure to enhance health outcomes for the underserved in the Palmer community. This project will introduce a dedicated community case manager, who will act as a bridge between service providers and individuals in need, ensuring that the latter receive the required care and support.

As a trusted connector organization for the Mat-Su mobile crisis team (MCT), Daybreak possesses a strong collaborative relationship with several provider agencies in the Palmer and Mat-Su community. Leveraging these established relationships, the new community case manager will be optimally positioned to coordinate and improve access to services, leading to improved health outcomes for those most in need.

We seek grant funding to facilitate the successful implementation of this pilot project. The grant will support the hiring and training of a community case manager, along with the necessary administrative infrastructure to efficiently support this role. The long-term vision is to develop a sustainable model that can be replicated throughout the region, contributing significantly to the overall well-being of our community.

II. Objectives

1. Improve access to essential health services and resources for targeted populations in Palmer.
2. Enhance community awareness and understanding of mental health and homelessness issues.
3. Provide critical resources to underserved individuals, including personal identification, hygiene necessities, and digital connectivity.
4. Develop local staffing and infrastructure focused on improving health outcomes for Palmer residents.
5. Engage local community members in emergency response activities.
6. Foster collaborations with local agencies to improve overall health for high-risk, underserved Palmer residents.

III. Strategies

1. Establish a dedicated community case manager role to facilitate improved access to health insurance, mental health services, and substance use disorder treatment. This role will also actively destigmatize existing services and support resource coordination.
2. Implement community outreach activities, such as the Palmer Resource Day event, to promote understanding and acceptance of mental health and homelessness issues.
3. Provide resources like State identification cards, track phones, hygiene kits, and other essential items to high-risk underserved Alaskans living in Palmer.
4. Contract with Connect Palmer to offer back-to-work training and skill development for individuals and families wishing to rejoin the workforce.
5. Develop a local plan to improve health outcomes for higher-risk underserved Alaskans, including better use of community facilities for social distancing.
6. Establish local advisory groups that include representation from higher-risk underserved populations to inform emergency response activities.
7. Build partnerships with local health and non-health agencies to implement strategies that improve overall health outcomes.

IV. Expected Outcomes

1. Increased access to health insurance, mental health services, and substance use disorder treatment for targeted populations.
2. Improved community understanding and acceptance of mental health and homelessness issues.
3. Provision of essential resources, including State identification cards, track phones, hygiene kits, and other essential items, to at least 100 high-risk individuals over the course of 12 months.
4. Enhanced skillsets and employment readiness among individuals and families participating in the back-to-work training.
5. Established a community case manager position and supportive infrastructure leading to improved health outcomes for Palmer residents.
6. Developed local emergency response plan informed by local advisory groups consisting of representatives from high-risk underserved populations.
7. Increased collaboration with local health and non-health agencies leading to improved overall health outcomes for high-risk, underserved Palmer residents.

V. Budget

- \$1,500 for state identification.
- \$4,700 for track phones.
- \$1,200 for shower & laundry vouchers.
- \$1,000 for hygiene kits.
- \$10,000 for back-to-work training classes and materials.
- \$48,000 for a full-time community case manager.
- \$9,000 for case manager supervision.
- \$12,000 for office space rent.
- \$1,600 for office supplies and equipment.

The total proposed budget is approximately \$88,000. This investment will serve as a catalyst for change in our community, bridging gaps between services and the individuals who need them most, thereby improving health outcomes and quality of life for our underserved residents.

**City of Palmer
Action Memorandum No. 23-030**

Subject: Approving a Request from Arctic Winter Games 2024 to Waive Facility Use Fees up to \$32,205 for the Usage of the MTA Events Center and the Palmer Train Depot during March of 2024

Agenda of: May 23, 2023

Council Action: **Approved** **Amended:** _____
 Defeated

Originator Information:

Originator: John Moosey, City Manager

Department Review:

Route to:	Department Director:	Signature:	Date:
_____	Community Development	_____	_____
_____	Finance	_____	_____
_____	Fire	_____	_____
_____	Police	_____	_____
_____	Public Works	_____	_____

Certification of Funds:

Total amount of funds listed in this legislation: \$ **32,205 In Kind**

This legislation (√):

- Creates revenue in the amount of: \$ _____
- Creates expenditure in the amount of: \$ _____
- Creates a saving in the amount of: \$ _____
- Has no fiscal impact

Funds are (√):

- Budgeted Line item(s): _____
- Not budgeted _____

Director of Finance Signature: 

Approved for Presentation By:

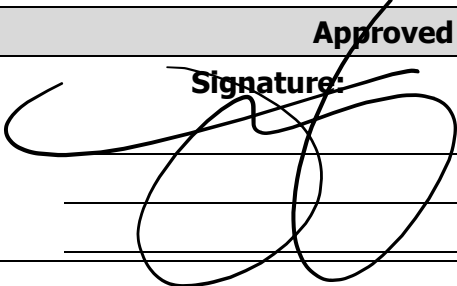
	Signature:	Remarks:
City Manager		_____
City Attorney	_____	_____
City Clerk	_____	_____

Attachment(s):

1. Request letter from Arctic Winter Games

Summary Statement/Background:

Mat-Su Borough has been selected to host the 2024 Arctic Winter Games, which will take place March 10-16, 2024. Palmer will be hosting the curling competition at the MTA Events Center and using the Palmer Depot as the AWG2024 Headquarters. The City of Palmer will welcome approximately 4,000 visitors creating a substantial positive economic impact for the community. From past Games in other communities, the average visitor has spent around \$2,500 during the week on food, housing, and merchandise.

Administration's Recommendation:

Approve Action Memorandum No. 23-030.



Mat-Su 2024 Arctic Winter Games Host Society
902 E Palmer-Wasilla Hwy
Palmer, AK 99645

Palmer City Council
231 W. Evergreen Ave.
Palmer, AK 99654

April 13, 2023

Dear Manager Moosey, Mayor Carrington, and Palmer City Council Members,

As you know, the Mat-Su Borough has been selected to host the 2024 Arctic Winter Games, which will take place March 10-16, 2024. The Games are an athletic and cultural celebration of the Circumpolar North, bringing together athletes, coaches, spectators, and dignitaries from Yukon, Northwest Territories, Northern Alberta, Nunavut, Nunavik, Greenland, Sapmi (Nomadic people of Scandinavia), and communities across Alaska.

During the Games, the City of Palmer will welcome approximately 4,000 visitors creating a substantial positive economic impact for the community. From past Games in other communities, we know that the average visitor will spend around \$2500 during the week in food, housing, and merchandise. Beyond this economic impact, the invaluable friendships formed between visiting leaders and participants will further relationship building and problem-solving between our Arctic communities. A truly local benefit is the exposure to healthy, northern, recreational activities that can inspire participation and increased winter wellness.. Finally, at a time in history of great division, this event brings people together. It is projected that 2,000 local and international guests will volunteer to make the Mat-Su 2024 Arctic Winter Games a success. This is a giant step in cooperation and resource sharing - northern values we all embrace.

We are writing today to thank the City of Palmer and the Palmer City Council for your support of the Games and to ask for your continued assistance. While the twenty sports and dozens of cultural events will take place throughout the Mat-Su, we are excited to be hosting the curling competition at the MTA Events Center and using the Palmer Depot as our AWG2024 Headquarters.. The headquarters will be a hub for pin trading, host pop-up cultural performances, and serve as the Alumni Lounge. The Host Society requests the City Council grant a waiver of facility use fees of up to \$32,205 for these facilities. While waiving the facility fees comes at a cost to the City, we believe it will be an investment that will pay for itself in increased revenue.

Palmer is highlighted throughout Games week throughout our community. Our headquarters, located at 902 E Palmer-Wasilla Highway, is home to our fifteen board members supported by thirteen staff members, and our primary merchandise store. In addition, our Warehouse and Arts Center is in the heart of downtown at The Barn (the former feed mill) on S. Colony Way. We are so excited to be working with Palmer Middle School to host Volleyball and Snowshoe Sprints and Palmer High School, which will serve as a participant village for 500 youth and host Futsal, a popular indoor soccer sport with 235 participants. In addition, most contingents will have opportunities to come to Palmer for recreational swimming. Beyond the City boundaries, but still in Palmer zip code, the Musk Ox Farm will host a tour for participants, and the APU Kellogg Campus will be home to the Snowshoeing competition. The Glenn Massay Theater will serve as the heart of our cultural programming as it will be where the Cultural Gala will take place. The Alaska State Fair will be home to our Traditional Feast, participant youth dance, fireworks display, Winter Carnival and Makers Market. In a lot of ways, we are bringing the heart of our Games to Palmer next year and with the Games, increased commerce, international friendships, and fun and healthy recreational opportunities for our youth and families.

Thank you for considering our fee waiver request. We look forward to partnering with the City of Palmer to host this exciting event. Please feel free to contact us with any questions you may have, and please stop in our headquarters to say hello!

Sincerely,



Amy Spargo, Chair
amy.spargo@awg2024.org



Ben Rowell, Venue Manager
ben.rowell@awg2024.org

**City of Palmer
Action Memorandum No. 23-031**

Subject: Authorizing the City Manager to Negotiate, Execute and Commit a Downpayment of \$25,000 for a Sole Purchase of An Ice Resurfacers from Zamboni Company USA, Inc.

Agenda of: May 23, 2023

Council Action: **Approved** **Amended:** _____
 Defeated

Originator Information:

Originator: Brad Hanson, Director of Community Development

Department Review:

Route to:	Department Director:	Signature:	Date:
_____	Community Development		May 3, 2023
_____	Finance	_____	_____
_____	Fire	_____	_____
_____	Police	_____	_____
_____	Public Works	_____	_____

Certification of Funds:

Total amount of funds listed in this legislation: \$ 25,000

- This legislation (√):
- Creates revenue in the amount of: \$ _____
 - Creates expenditure in the amount of: \$ 25,000
 - Creates a saving in the amount of: \$ _____
 - Has no fiscal impact

Funds are (√):

- Budgeted Line item(s): 08-01-05-6253
- Not budgeted _____

Director of Finance Signature: _____

Approved for Presentation By:

	Signature:	Remarks:
City Manager		_____
City Attorney	_____	_____
City Clerk	_____	_____

Attachment(s):

1. Product Proposal – Zamboni Company USA, INC.

Summary Statement/Background:

The City of Palmer purchased a used ice resurfacer (Zamboni) that was manufactured in 1999. This machine has 7,858 hours and is nearing the end of its useful life. Ice resurfacers are necessary to operate an indoor ice arena, they are used to shave the ice and lay down a layer of water that levels the ice. In 2022 the city created a Capital Account for the replacement of the ice resurfacer and mechanical equipment at the MTA Events Center. The account currently has \$136,244 for the purchase of an ice resurfacer. In December 2022 the city was awarded an energy grant from the United States Department of Energy. The amount of the grant is \$75,250, for a combined total of available funds of \$211,494.

The U.S. Department of Energy (DOE) released a Notice of Intent (NOI) to issue funds for the \$550 million Energy Efficiency and Conservation Block Grant (EECBG), which was funded through the Bipartisan Infrastructure Law (BIL). The EECBG Program will award formula grants directly to local governments, cities, boroughs, states and tribes across the country to implement strategies to reduce fossil fuel emissions, decrease total energy use and improve energy efficiency. Project eligibility includes electrification of fleets and that the product is manufactured in the United States.

This Action Memorandum authorizes the sole source purchase of the ice resurfacer from Zamboni Company USA, Inc. Zamboni is a recognized leader in the ice resurfacer industry, all rinks in Alaska currently utilize them. Model 552AC is the electric model which will significantly improve air quality and reduce operating costs in the MTA Events Center, creating a healthier environment for our patrons. Our current propane model leaves a film of exhaust on the dasher board glass requiring constant cleaning. Additionally, propane expenses will be eliminated which amounts to \$5000 annually. Model 552AC will be equipped with a level ice system that automates ice reconditioning. This system will further reduce operating costs, by reducing employee training, ice maintenance and reduced compressor run times to keep ice at the proper temperature.

Delivery lead times are currently 500 days, pricing is guaranteed for 30 days from the proposal date. The proposed price will not exceed \$194,000 F.O.B. Paramount California.

Administration’s Recommendation:

Approve Action Memorandum No. 23-031 for the sole source purchase of a Zamboni Ice Resurfacer.

May 3, 2023

Brad Hanson
City of Palmer
645 E Cope Industrial Way
Palmer, AK 99645



PROPOSAL

“The principal product you have to sell is the ice itself.”

– Frank J. Zamboni

Maintaining an ice surface presents a multitude of challenges. Having efficient and reliable resurfacing equipment should not be one of them. Driven by our founder’s commitment to innovation, we put our product to the test in the harsh environment it will call home. Every feature is deliberately designed to make resurfacing easier and to ensure that the end result is an exceptional sheet of ice. Built by hand. One at a time. The result is an ice resurfacing machine legendary for its quality, durability and superior performance.

MODEL 552AC:

Clean ice. Clean air. Clear choice. Building upon the solid reputation of its predecessor, the Model 552AC features worry-free AC motors and controls, introducing new efficiencies and virtually eliminating associated maintenance. The battery package is easy to access and maintain. Proven and dependable controls built for tough industrial applications. Microprocessor controlled smart chargers deliver long battery life. The Model 552AC provides a low maintenance option for your high maintenance surface.

MODEL 552AC LITHIUM-ION (OPTIONAL):

Zero battery maintenance and lithium-ion power combine for the ultimate upgrade to the world’s most popular electric ice resurfer. Lithium-ion batteries charge quickly between resurfacings, eliminating overnight charging. Sealed zero maintenance batteries are truly emission-free. Charging is controlled by battery management system to optimize charging and balancing. Strong conveyor performance at any speed. Our unrivaled down pressure system ensures that all you leave behind is perfect.

INNOVATION:

Our commitment to constant innovation is an investment in the end product. We apply decades of experience working with facility owners and operators into every decision we make. Automated processes provide a consistent end result and reduce the chance for operator error. Opportunities to retrieve and display data from the machine provide a new tool in rink management. The incremental and continued introduction of new and better technologies to our ice resurfacing machines facilitates savings of time and valuable resources.

ZAMBONI®

QUALITY:

Zamboni sets the standard of quality to which the industry is held. The Zamboni Company holds itself to an even higher standard with ongoing assessment and meticulous quality control, resulting in products which consistently produce the finest sheet of ice even after many years of use. Our rugged four-wheel drive chassis is hand-built using strong all-welded steel tubing. Premium materials and components are used throughout. We continually collaborate with our customers to ensure the products that will ultimately end up in their facility exceed the high expectations of quality associated with our brand.

VALUE:

Zamboni has a well-deserved reputation as the Industry Leader. One which we don't take for granted. Our products have the lowest cost of operation and maintain the highest residual value. A network of Zamboni Authorized Distributors and our own Customer Service teams provide local service and support for our products. In the world of ice, time is money and unreliable equipment can be a show-stopper. Yet another reason that worldwide, more facility operators choose Zamboni for their ice resurfacing needs. Nothing else is even close.

MACHINE SPECIFICATIONS:

Machine specifications are also available online. Please copy the web links below into your browser.
https://zamboni.com/wp-content/uploads/specs/552AC_specs.pdf
https://zamboni.com/wp-content/uploads/specs/552AC_Lithium-ion_specs.pdf

MANUFACTURER'S STATEMENT:

This machine is proudly designed and manufactured in Paramount, California by Zamboni Company USA, Inc., a United States company.

WARRANTY:

Twenty-Four (24) months or 2,000 hours, whichever comes first, parts replacement only.

SAFETY STANDARDS:

This machine is engineered to meet or exceed OSHA and ANSI safety labeling requirements. In addition to digital safety information, operating instructions and service manuals being provided with the delivery of the machine, all owners/operators have access to all of these materials online at www.zamboni.com to view and download at any time.

FOR ADDITIONAL INFORMATION:

zamboni.com/machines/model-552ac

zamboni.com/machines/model-552ac-lithium-ion

zamboni.com/options

Zamboni 552AC \$ **136,000.00**

STANDARD EQUIPMENT INCLUDES:

510 AH Lead Acid Battery with Charger, Aluminum Wheels, Guide Wheel, Black Powder Coated Conditioner, Parking Brake, Conditioner Poly Side Plate, Spare Tire & Wheel Assembly, (2) 77" Blades

ADDITIONAL EQUIPMENT:

Lithium Ion Battery and Charger (In Lieu of Lead Acid)	\$	13,750.00
Back Up Alarm	\$	700.00
Board Brush	\$	6,495.00
Power Brush Fill	\$	120.00
Wash Water System w/ Poly Tank	\$	5,450.00
Water Gun for Batteries (LA Battery Only)	\$	155.00
Electronic Water Level Sight Gauge	\$	505.00
Snow Tank Light	\$	175.00
Advanced Water System	\$	12,000.00
Tire Wash System	\$	1,500.00
Auto Snow Breaker	\$	1,985.00
Stainless Steel Water Distribution Pipe	\$	155.00
Viscous Coupling Drive Shaft	\$	1,925.00
Single Point Watering System for Batteries (LA Battery Only)	\$	1,000.00
Integrated Auger Wash Out System	\$	1,395.00
Zamboni Connect (Includes 2-year subscription)	\$	1,000.00
Conti Blade Changer	\$	1,000.00
Level Ice (installation & training additional)	\$	21,500.00
Fast Ice	\$	10,000.00

\$ 188,500

F.O.B:

Paramount, California USA

TERMS:

\$25,000.00 deposit with order, balance Net 30 days from date of shipment. Shipment 500 days or sooner from receipt of order. Pricing firm for 30 days. Pricing does not include any applicable sales tax.

THANK YOU:



Doug Peters,
Regional Sales Manager

May 3, 2023

Date

Zamboni Company USA, Inc.

15714 Colorado Ave. Paramount, California 90723 USA
Phone: +1 562 633 0751 Fax: +1 562 633 9365

**City of Palmer
Action Memorandum No. 23-032**

Subject: Authorize the City Manager to Execute Change Order Number Four Option with Alaska Sure Seal in the Amount of \$46,000 for Yellow Curb Painting along roadways

Agenda of: May 23, 2023

Council Action: **Approved** **Amended:** _____
 Defeated

Originator Information:

Originator: Jude Bilafer, Director of Public Works

Department Review:

Route to:	Department Director:	Signature:	Date:
_____	Community Development	_____	_____
_____	Finance	_____	_____
_____	Fire	_____	_____
_____	Police	_____	_____
X	Public Works	<i>JPB</i>	05/03/2023

Certification of Funds:

Total amount of funds listed in this legislation: \$ **46,000**

This legislation (√):

Creates revenue in the amount of: \$ _____

Creates expenditure in the amount of: \$ **46,000**

Creates a saving in the amount of: \$ _____

Has no fiscal impact

Funds are (√):

Budgeted Line item(s): 08-01-10-7182

Not budgeted _____

Director of Finance Signature: *[Signature]*

Approved for Presentation By:

	Signature:	Remarks:
City Manager	<u><i>[Signature]</i></u>	_____
City Attorney	_____	_____
City Clerk	_____	_____

Attachment(s):

Yellow Curb Paint 2023					
Item	Description	Unit	Unit Price	Quantity	Total
14	Yellow Curb Paint	LF	\$ 1.52	30,263	\$ 46,000.00
	Total				\$ 46,000.00

Summary Statement/Background:

The Department of Public Works is requesting to exercise option **Change Order Four** for the 2023 Crack Sealing and Street Striping Contract with Alaska Sure Seal. This was bid and awarded to Alaska Sure Seal through Council action in AM 21-028. The City and the Contractor have mutually agreed to exercise the Second one-year renewal option and the funds are budgeted in line item 08-01-10-7182. This **Change Order Four** reflects the change in quantity adding Yellow Curb Painting to contract and extends the contract completion date. The unit prices were adjusted and reflect additional costs of materials and shipping.

Administration's Recommendation:

To approve Action Memorandum No. 23-032.

**City of Palmer
Action Memorandum No. 23-033**

Subject: Authorizing Utility Connection for AMG & Associates, Located at 12821 E. Scott Road, Palmer, Alaska

Agenda of: May 23, 2023

Council Action: **Approved** **Amended:** _____
 Defeated

Originator Information:

Originator: John Moosey, City Manager

Department Review:

Route to:	Department Director:	Signature:	Date:
_____	Community Development	_____	_____
_____	Finance	_____	_____
_____	Fire	_____	_____
_____	Police	_____	_____
X	Public Works	<i>JPB</i>	05/03/2023

Certification of Funds:

Total amount of funds listed in this legislation: \$ _____

This legislation (√):

- Creates revenue in the amount of: \$ _____
- Creates expenditure in the amount of: \$ _____
- Creates a saving in the amount of: \$ _____
- Has no fiscal impact

Funds are (√):

- Budgeted Line item(s): _____
- Not budgeted _____

Director of Finance Signature: *[Signature]*

Approved for Presentation By:

	Signature:	Remarks:
City Manager	<u><i>[Signature]</i></u>	_____
City Attorney	_____	_____
City Clerk	_____	_____

Attachment(s):

1. Site Plan

Summary Statement/Background:

A multifamily development is currently being designed by The Boutet Company for AMG & Associates. This development will consist of 10 fourplexes and a community building on a 4.79 acre parcel located off Scott Road. AMG & Associates are requesting permission to connect to the City's existing wastewater system running alongside the property limits. This development will be a benefit to the City's wastewater enterprise operation. The Manager is recommending City Council approval.

Administration's Recommendation:

Approve Action Memorandum No. 23-033



The Boutet Company, Inc.
1508 E Bogard Rd., Unit 7
Wasilla, Alaska 99654

Phone 907.357.6770
www.tbca.com

April 4, 2023

Jude Bilafer
Public Works Director
City of Palmer
231 W. Evergreen Ave.
Palmer, AK 99645

RE: 12821 E. Scott Rd Sewer Extension

Dear Mr. Bilafer,

TBC has been retained by AMG & Associates to design a multifamily development consisting of 10 fourplexes and a community building on a 4.79 acre parcel located at 12821 E. Scott Rd in Palmer, AK, legal description: Township 18N Range 2E Section 32 Lot A39. This property is just outside of Palmer City limits.

On behalf of the developer, we would like to request that the project be served by City of Palmer's Wastewater System. The connection to the system would require extension from the subject property to an existing manhole on the existing main crossing Scott Road to service Farm Overlook Parcel 3 located at 12305 E. Scott Road. This main extension would require approximately 950' of new sewer pipe. Due to the elevation difference between the development site and the existing manhole and the main being higher than the project site, we are proposing a forced main for the extension. The proposed main will consist of dual 3" HDPE SDR 11 pipes. Pressurized onsite with two grinder pumps installed in an 8' diameter manhole. Two pumps and dual 3" HDPE pipes are proposed for redundancy. The manhole and pump controls will be sized/set to be able to store a minimum of 20 minutes at peak discharge. The specified pumps will have a flow rating higher than the peak demand at sufficient pressure to provide 5 psi residual pressure at the connection to the existing manhole. Design will be completed as required by your department, per the City of Palmer's standard specifications and taking guidance from the Anchorage Water and Wastewater Utility's Design and Construction Practices Manual (AWWU DCPM). The preliminary plan and profile for the extension is attached.

We appreciate the consideration by CoP to serve this development. Please contact myself or Hans Hill at (907) 357-6770 with an questions or request further information.

Sincerely,

Tim Alley, PE
Principal/Wasilla Office Manager
The Boutet Company, Inc

1508 E Bogard Rd., Unit 7, Wasilla, Alaska Phone: 907-357-6770 Fax: 907-357-6750 Email: talley@tbca.com

DRAWING LOCATION: W:\WasillaFiles\H3 Investment\Palmer - Scott Road MF Housing\ACAD\BREEZY MEADOWS PSH 1 Title.dwg
 DESIGNED BY: N/A
 CHECKED BY: N/A
 DRAFTED BY: N/A
 PLOT DATE: 3/30/2023
 SCALE: N/A
 SHEETS: 1

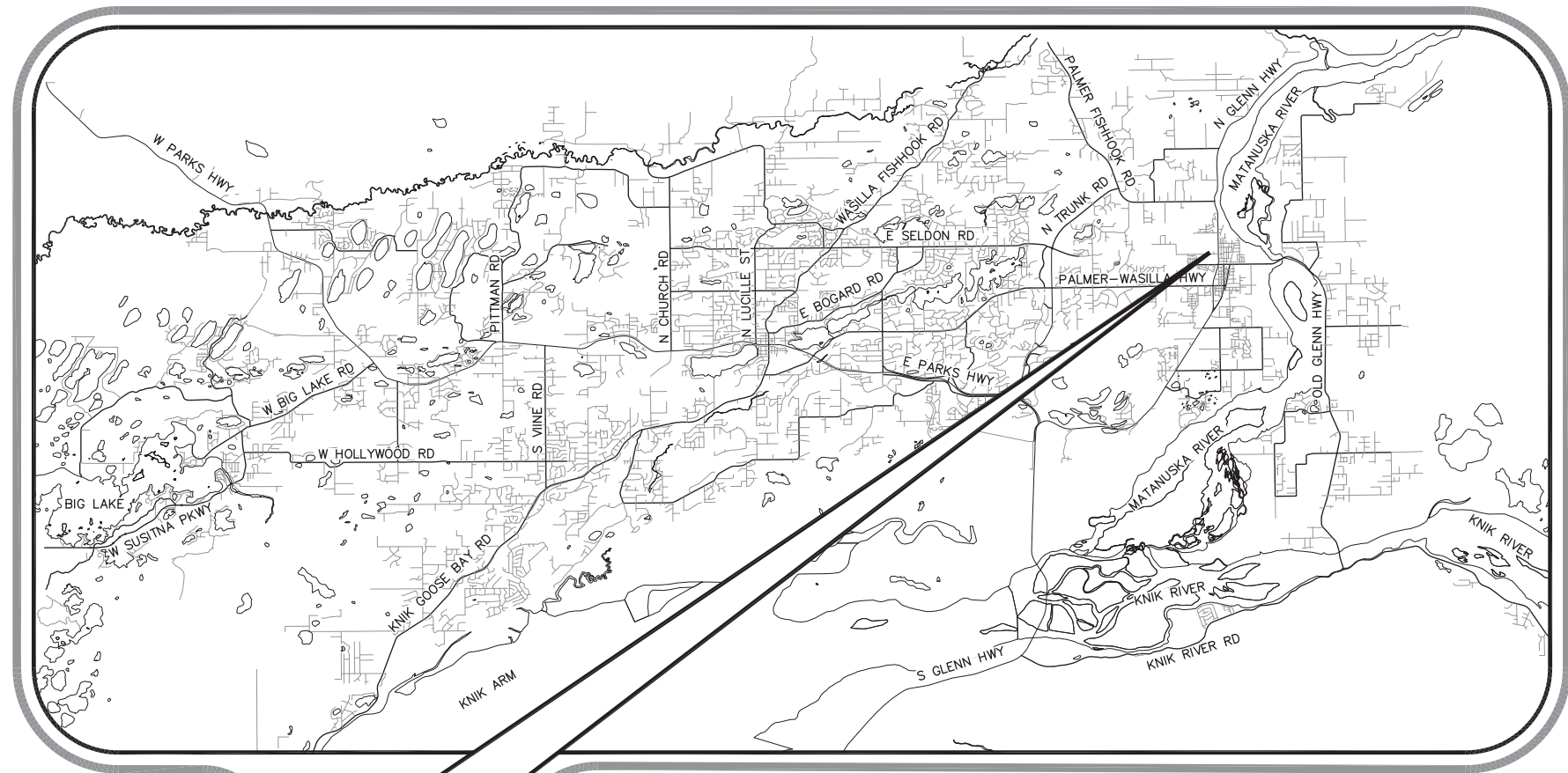

**MAT-SU BOROUGH CORE AREA
VICINITY MAP**

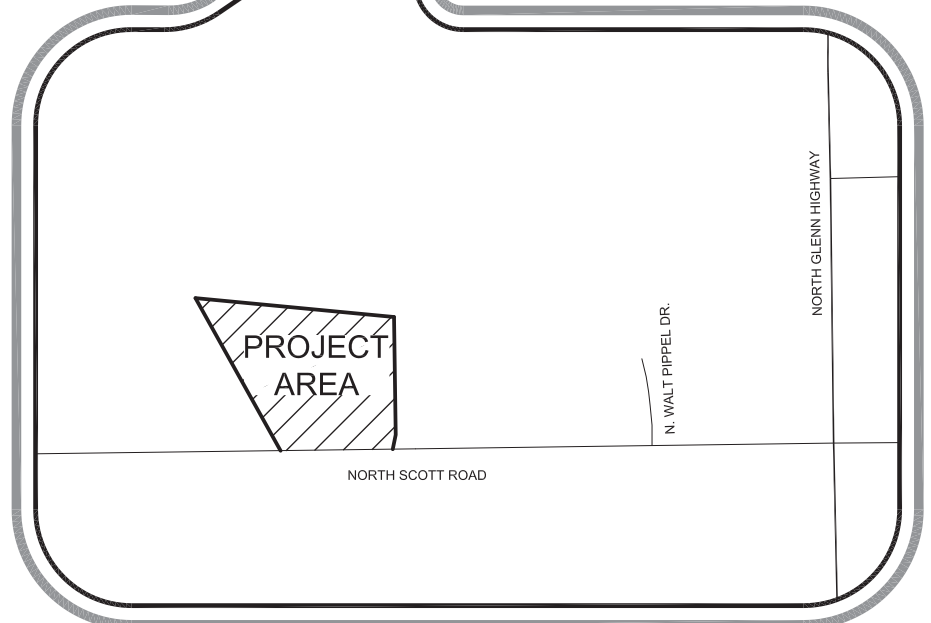

**BREEZY MEADOWS PHASE 1
VICINITY MAP
(NTS)**

BREEZY MEADOWS PHASE 1

PALMER, AK

CIVIL SITE & UTILITY IMPROVEMENTS

LEGAL DESCRIPTION:
TOWNSHIP 18N RANGE 2E SECTION 32
LOT A39

PROPERTY OWNER INFORMATION:
AMG & ASSOCIATES LLC
PO BOX 260770
ENCINO, CA 91426

DEVELOPER INFORMATION:
PACIFIC WEST COMMUNITIES, INC.
430 E. STATE ST., SUITE 100
EAGLE, ID 83616

SHEET INDEX	
SHEET NO.	SUBJECT
C1	COVER SHEET
EX1-EX2	OFF SITE SEWER PLAN AND PROFILE



The Boutet Company, Inc.
601 E. 57th Place #102
Anchorage, AK. 99518
Ph. 907-522-6776
License No. AECC957

DATE: 3/30/2023

FILE:SEWER SCOTT ROAD.DWG
 DATE/TIME 3/30/23
 LAYOUT
 DESIGNED HJH
 CHECKED TJA
 DRAFTED CBW

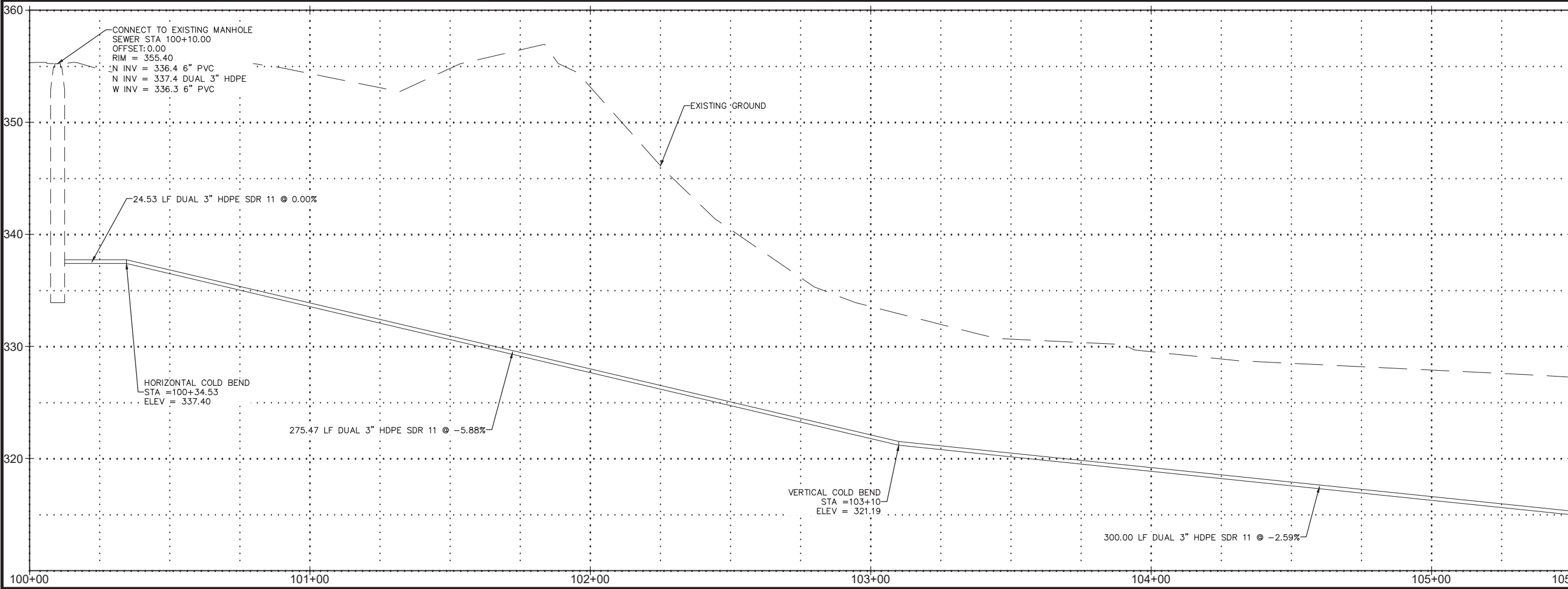
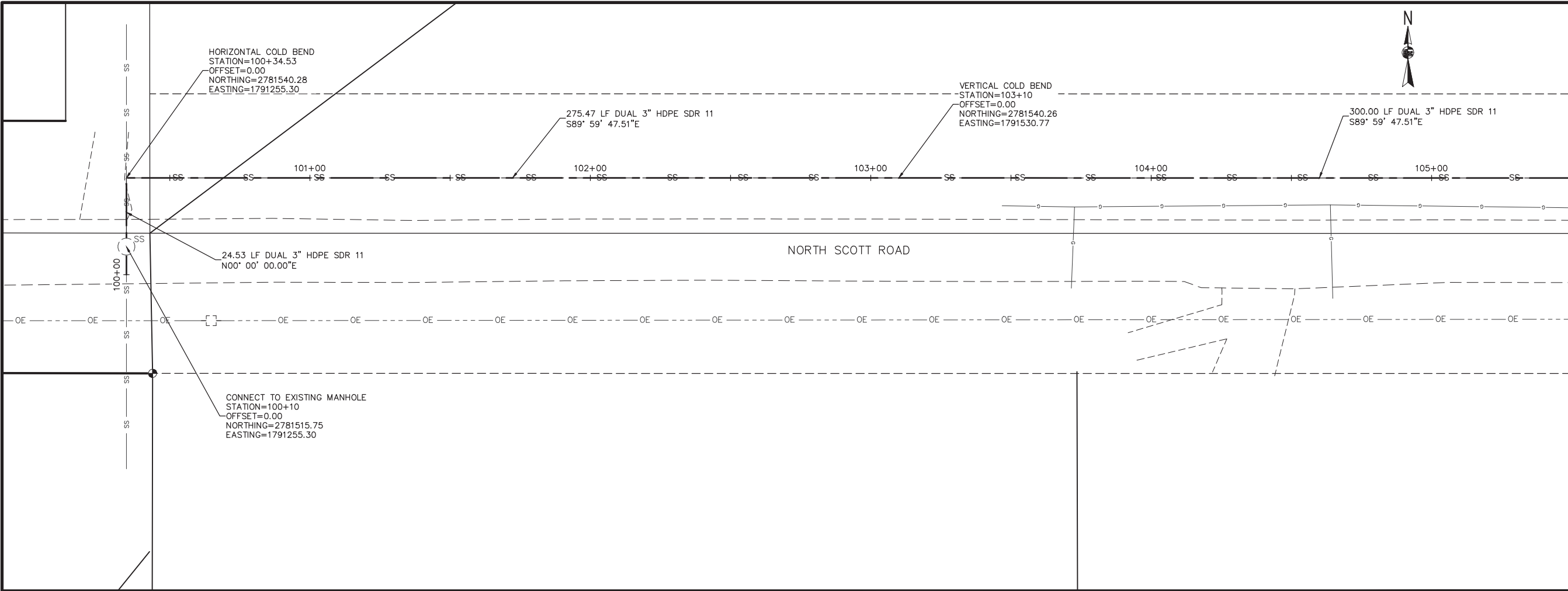

SHEET NO.	TOTAL SHEETS
EX1	EX2
STATE	YEAR
ALASKA	2023
PROJECT DESIGNATION	
NO.	REVISION
DATE	
NO.	REVISION
DATE	
NO.	REVISION
DATE	

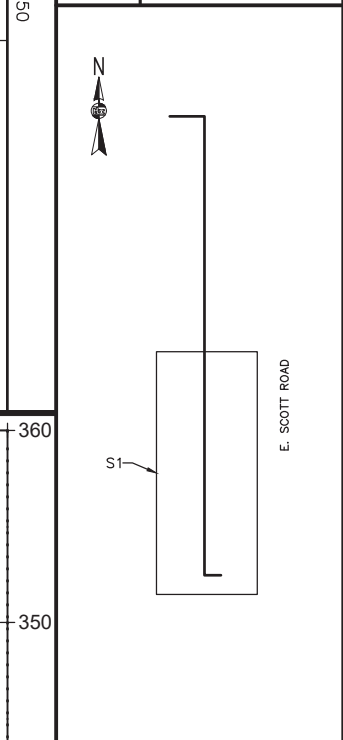

hbc
 The Boutet Company, Inc.
 601 E. 57th Place #102
 Anchorage, AK, 99518
 Ph. 907-522-6776
 License No. AECC957

65% REVIEW
 3/30/2023

BREEZEY MEADOWS PHASE 1
 PALMER, ALASKA

**OFF SITE SEWER
 PLAN AND PROFILE
 STA 100+10 - 105+50**

FILE:SEWER SCOTT ROAD.DWG
 DATE/TIME 3/30/23
 LAYOUT
 DESIGNED HJH
 CHECKED TJA
 DRAFTED CBW

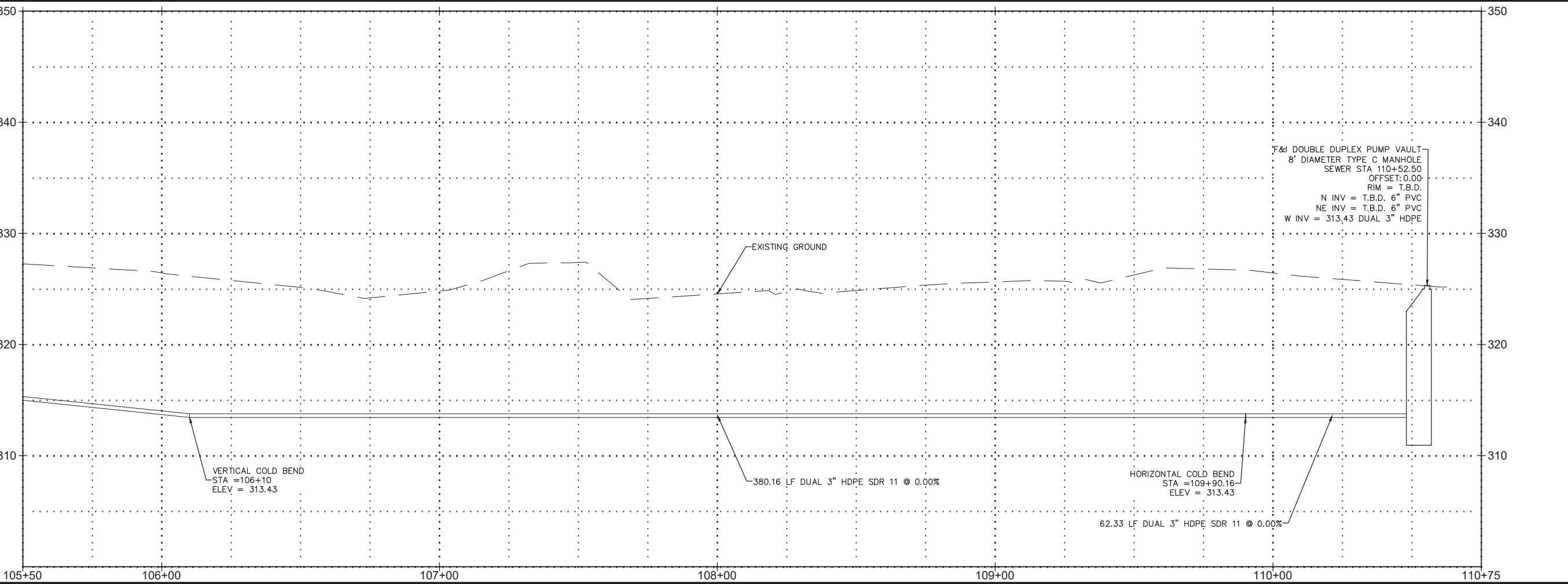
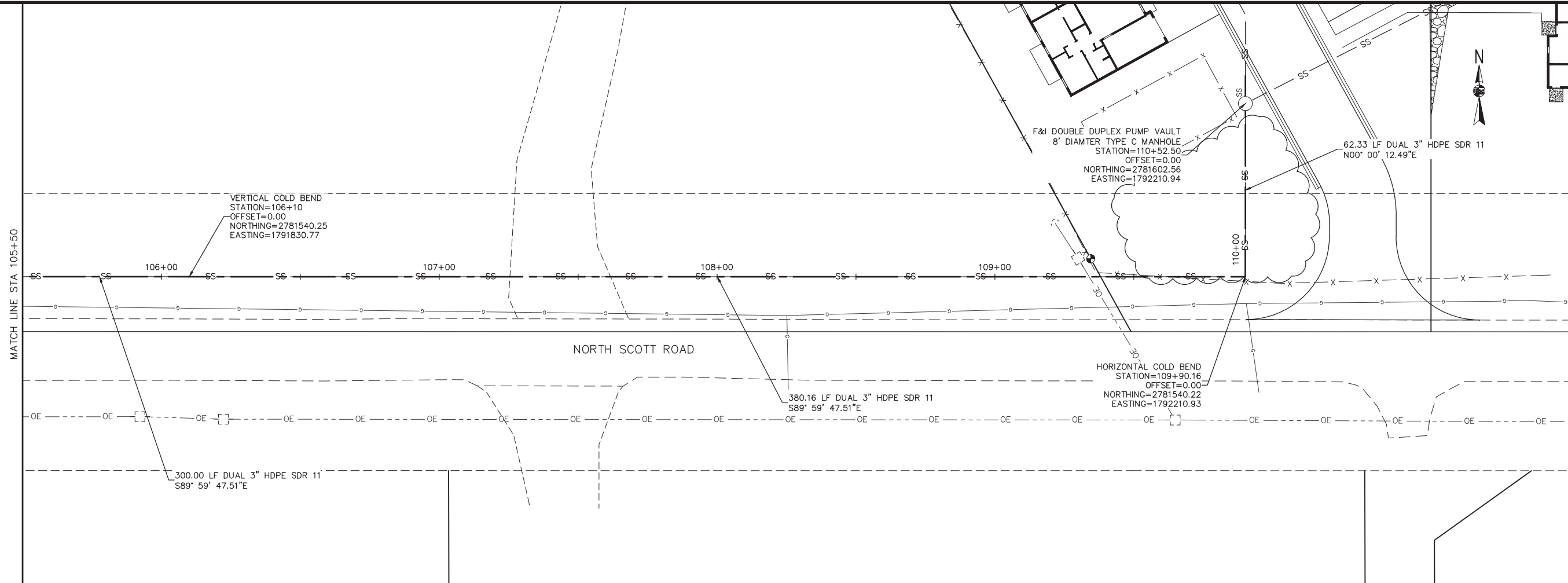

SHEET NO.	TOTAL SHEETS
EX2	EX2
STATE	YEAR
ALASKA	2023

PROJECT DESIGNATION

NO.	REVISION

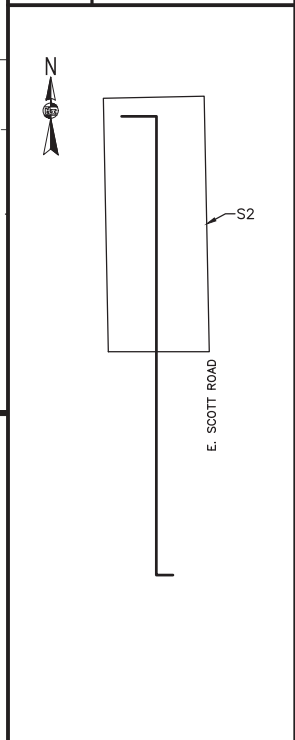

The Boutet Company, Inc.
 601 E. 57th Place #102
 Anchorage, AK, 99518
 Ph. 907-522-6776
 License No. AECC957

65% REVIEW
 3/30/2023

BREEZEY MEADOWS PHASE 1
 PALMER, ALASKA

OFF SITE SEWER
 PLAN AND PROFILE
 STA 105+50 - 110+52.50

**City of Palmer
Action Memorandum No. 23-034**

Subject: Authorizing the City Manager to Negotiate and Enter into a Contract with Northern Insulation Solutions Inc., in an Amount Not to Exceed \$867,568.00 for the 2023 Palmer Reservoir 4 Insulation Repairs Project.

Agenda of: May 23, 2023

Council Action: **Approved** **Amended:** _____
 Defeated

Originator Information:

Originator: Jude Bilafer, Director of Public Works

Department Review:

Route to:	Department Director:	Signature:	Date:
_____	Community Development	_____	_____
_____	Finance	_____	_____
_____	Fire	_____	_____
_____	Police	_____	_____
X	Public Works	<i>JPB</i>	05/03/2023

Certification of Funds:

Total amount of funds listed in this legislation: \$ **\$867,568.00**

This legislation (√):

Creates revenue in the amount of: \$ _____

Creates expenditure in the amount of: \$ **\$867,568.00**

Creates a saving in the amount of: \$ _____

Has no fiscal impact

Funds are (√):

Budgeted Line item(s): **24-52-10-6226 Reservoir 4 Repairs \$316,631**

Not budgeted Advance from General Fund Unassigned Fund Balance Waiting on Insurance reimbursement

Director of Finance Signature: *[Signature]*

Approved for Presentation By:

	Signature:	Remarks:
City Manager	<u><i>[Signature]</i></u>	_____
City Attorney	_____	_____
City Clerk	_____	_____

Attachment(s):

1. HDL Recommendation Letter & Bid Tabulation

Summary Statement/Background:

This project will repair the damage to Palmer’s Water Reservoir #4 which was damaged during the January 2022 windstorm. This project will be funded through the City’s property insurance. The City has received \$316,631 for the start of this project. Resolution 23-0XX advanced funds from the General Fund unassigned fund balance for the project to be reimbursed by the City’s insurance company once the repairs are complete.

Administration’s Recommendation:

Approve Action Memorandum No. 23-034.

May 1, 2023

Jude Bilafer
 Director of Public Works
 City of Palmer
 231 West Evergreen Avenue
 Wasilla, AK 99645

Subject: Recommendation of Award
 Palmer Reservoir 4 Insulation Repairs

We have reviewed the bids submitted for the above-referenced project and have not noted any bid errors. However, we have interpreted the bid from H Construction, LLC as nonresponsive.

H Construction, LLC based their bid on a substitute insulation system as manufactured by Insultherm Industrial Services. The substitute insulation system utilizes an interior banding and clip system for horizontal tank shell insulation panels. The Contract Documents require an exterior band and clamp system for horizontal tank shell insulation panels. Based on this requirement, the insulation system proposed by H Construction, LLC is not an equal product to the Basis of Design insulation system.

The bid totals for each schedule and the corresponding contractor rankings are summarized below:

Table 1: Contractor Bid Rankings for Schedule A

Rank	Contractor	Base Bid
1	H Construction, LLC	\$669,000.00
2	CCI Industrial Services, LLC	\$853,715.00
3	Northern Insulation Solutions Inc.	\$855,055.00
	Engineer's Estimate	\$710,000.00

Table 2: Contractor Bid Rankings for Schedule B

Rank	Contractor	Base Bid
1	H Construction, LLC	\$685,000.00
2	Northern Insulation Solutions Inc.	\$867,568.00
3	CCI Industrial Services, LLC	\$876,266.00
	Engineer's Estimate	\$750,000.00

- Civil Engineering
- Geotechnical Engineering
- Transportation Engineering
- Aviation Engineering
- W/WW Engineering
- Environmental Services
- Surveying & Mapping
- Construction Administration
- Material Testing

Palmer Reservoir 4 Insulation Repairs
May 1, 2023

Based our understanding of the intent to award Schedule B and on the above summary, we recommend award of the contract to Northern Insulation Solutions Inc. subject to approval of funding sources.

Please contact us if you need anything further.

Sincerely,

HDL Engineering Consultants, LLC



Chris Bowman, PE

Senior Civil Engineer

e: cbowman@HDLalaska.com | o: 907.746.5230

Attach: Bid Tabulation (1 page)

CITY OF PALMER
Reservoir 4 Insulation Repairs
BID SUMMARY

SUMMARY

Schedule	Engineer's Estimate	H Construction, LLC	Northern Insulation Solutions	CCI Industrial Services, Inc.
Calculated Schedule A Total	\$710,000.00	\$669,000.00	\$855,055.00	\$853,715.00
As Submitted Schedule A Total		\$669,000.00	\$855,055.00	\$853,715.00
Difference Schedule A	-	\$0.00	\$0.00	\$0.00
Calculated Total Base Bid	\$710,000.00	\$669,000.00	\$855,055.00	\$853,715.00
As Submitted Total Base Bid	-	\$669,000.00	\$855,055.00	\$853,715.00
Difference Total Base Bid	-	\$0.00	\$0.00	\$0.00
Calculated Schedule B Total	\$750,000.00	\$685,000.00	\$867,578.00	\$876,266.00
As Submitted Schedule B Total		\$685,000.00	\$867,578.00	\$876,266.00
Difference Schedule B	-	\$0.00	\$0.00	\$0.00
Calculated Total Base Bid	\$750,000.00	\$685,000.00	\$867,578.00	\$876,266.00
As Submitted Total Base Bid	-	\$685,000.00	\$867,578.00	\$876,266.00
Difference Total Base Bid	-	\$0.00	\$0.00	\$0.00
Acknowledged Addendum	-	Y	Y	Y
Bid Proposal signed	-	Y	Y	Y
10% Bid Bond	-	Y	Y	Y
Bidder Qualification Form	-	Y	Y	Y
Subcontractors & Suppliers List	-	Y	Y	Y
Product Data Certification Form	-	Y	Y	Y

**City of Palmer
Action Memorandum No. 22-0XX**

Subject: Authorizing the City Manager to Execute a Contract with HDL Engineering Consultants in the Amount not to exceed \$32,545.00 for Construction Administration Services for Reservoir #4 Insulation Repairs Project

Agenda of: May 23, 2023

Council Action: **Approved** **Amended:** _____
 Defeated

Originator Information:

Originator: Jude Bilafer, Director of Public Works

Department Review:

Route to:	Department Director:	Signature:	Date:
_____	Community Development	_____	_____
_____	Finance	_____	_____
_____	Fire	_____	_____
_____	Police	_____	_____
X	Public Works	<i>JPB</i>	05/03/2023

Certification of Funds:

Total amount of funds listed in this legislation: \$ **32,545.00**

- This legislation (√):
- Creates revenue in the amount of: \$ _____
 - Creates expenditure in the amount of: \$ **32,545.00**
 - Creates a saving in the amount of: \$ _____
 - Has no fiscal impact

- Funds are (√):
- Budgeted Line item(s): 24-52-10-6226 Reservoir 4 Repairs \$316,631
 - Not budgeted Advance from General Fund Unassigned Fund Balance Waiting on Insurance reimbursement

Director of Finance Signature: *[Signature]*

Approved for Presentation By:

	Signature:	Remarks:
City Manager	<u><i>[Signature]</i></u>	_____
City Attorney	_____	_____
City Clerk	_____	_____

Attachment(s):

1. HLD Construction Services Proposal

Summary Statement/Background:

Staff is requesting the Approval of \$32,545.00 for HDL to provide construction administration services during the Reservoir 4 Insulation Repairs Project. Reservoir 4 was heavily damaged during the January 2022 windstorm. The City has received \$316,631 for the start of this project. Resolution 23-035 advanced funds from the General Fund unassigned fund balance for the project to be reimbursed by the City's insurance company once the repairs are complete.

Administration's Recommendation:

To Approve Action Memorandum No. 23-035

**City of Palmer
Action Memorandum No. 23-036**

Subject: Authorize the City Manager to Purchase, Under the Governmental and Proprietary Procurements Section of Palmer Municipal Code 3.21.230, 50 Used Golf Carts From Moose Run Golf Course Not To Exceed \$125,000

Agenda of: May 23, 2023

Council Action: **Approved** **Amended:** _____
 Defeated

Originator Information:

Originator: Brad Hanson, Director Community Development

Department Review:

Route to:	Department Director:	Signature:	Date:
_____	Community Development		May 5, 2023
_____	Finance	_____	_____
_____	Fire	_____	_____
_____	Police	_____	_____
_____	Public Works	_____	_____

Certification of Funds:

Total amount of funds listed in this legislation: \$ \$125,000

- This legislation (√):
- Creates revenue in the amount of: \$ _____
 - Creates expenditure in the amount of: \$ \$125,000
 - Creates a saving in the amount of: \$ _____
 - Has no fiscal impact

Funds are (√):

- Budgeted Line item(s): 15-01-10-6200
- Not budgeted _____

Director of Finance Signature: 

Approved for Presentation By:

	Signature:	Remarks:
City Manager		_____
City Attorney	_____	_____
City Clerk	_____	_____

Attachment(s):

1. Moose Run Golf Cart Invoice

Summary Statement/Background:

Palmer City Council has approved \$140,000.00 for the purchase of golf carts for the Palmer Golf Course (PGC). This is an opportunity to significantly upgrade the fleet. Currently the PGC has about 50 running carts, comprised of 29 Club Cars, 2002 and 2007 models, and 21 Yamahas, 2009 and 2010 models.

The Moose Run Golf Course, which is a federally owned golf course is purchasing a new fleet and has agreed to sell 50 used 2016 Club Cars to PGC. The fleet's age and condition are becoming an issue for reliability and maintenance expense. The cost of new carts is approximately \$8000 each, \$400,000 for an equivalent fleet of 50, the expected lead time is two to three years for delivery.

Under the contract for professional services with Eagle Golf, the city of Palmer receives all revenue from cart rentals. The inability to provide reliable carts for tournaments and daily rentals is hurting the city's bottom line.

Palmer Municipal Code 3.21.230 allows for the purchase of goods and services from governmental sources without being competitively bid.

3.21.230 Governmental and proprietary procurements.

- A. The purchasing officer may contract, without the use of the competitive source selection procedures of this chapter, for the following supplies, services, professional services or construction:
 1. For contracts, including reimbursable agreements, with federal, state or local units of government or utility provider where the city has a financial responsibility or beneficial interest in entering into an agreement.
 2. For contracts issued pursuant to any federal, state, or local government contract where the city is an authorized user, or where the resulting contractor agrees to extend the same terms, conditions, and pricing to the city as those awarded under the original contract, all in accordance with PMC 3.21.240. Such agreements shall be limited to those contracts where the award is issued pursuant to a formally advertised solicitation.
 3. For contracts where the purchasing officer determines in writing that the city's requirements reasonably limit the source for the supplies, services, professional service or construction to one person.
- B. All contract awards under this section, and any amendments thereto, shall be subject to the applicable approval requirements of PMC 3.21.090 prior to execution.
- C. No contractor may provide supplies, services, professional services, or construction to the city before the applicable requirements of this section are first satisfied.

Administration's Recommendation:

Approve Action Memorandum No. 23-036.



Invoice

Moose Run Golf Course

Date: 3-May-23

Invoice #: No.1

Customer ID: Palmer

To: City of Palmer- Palmer Golf Course

Date	Program	Payment Terms	Due Date
03-05-23	Golf Cars	Due upon receipt	Delivery

Qty	Description	Unit Price	Line Total
50.00	2016 Club Car- Golf Car	\$ 2,500.00	\$ 125,000.00
			0.00
		Subtotal Sales Tax	\$ 125,000.00
		Total	
			\$ 125,000.00

payable to **Moose Run Golf Course**

Thank you for your business!

We can not sell current fleet until the new fleet arrives. George will get first pick of the golf cars once we are ready to sell.

**City of Palmer
Action Memorandum No. 22-0XX**

Subject: Authorizing the City Manager to Execute a Contract with HDL Engineering Consultants in the Amount not to exceed \$32,510.00 for Construction Administration Services for the 2023 Evergreen Avenue and Airport Road Pathway Project

Agenda of: May 23, 2023

Council Action: **Approved** **Amended:** _____
 Defeated

Originator Information:

Originator: Jude Bilafer, Director of Public Works

Department Review:

Route to:	Department Director:	Signature:	Date:
_____	Community Development	_____	_____
_____	Finance	_____	_____
_____	Fire	_____	_____
_____	Police	_____	_____
X	Public Works	<i>JPB</i>	05/03/2023

Certification of Funds:

Total amount of funds listed in this legislation: \$ **32,510.00**

This legislation (√):

- Creates revenue in the amount of: \$ _____
- Creates expenditure in the amount of: \$ **32,510.00**
- Creates a saving in the amount of: \$ _____
- Has no fiscal impact

Funds are (√):

- Budgeted Line item(s): 10-01-08-6200
- Not budgeted _____

Director of Finance Signature: *[Signature]*

Approved for Presentation By:

	Signature:	Remarks:
City Manager	<u><i>[Signature]</i></u>	_____
City Attorney	_____	_____
City Clerk	_____	_____

Attachment(s):

1. HLD Construction Services Proposal

Summary Statement/Background:

Staff is requesting the Approval of \$32,510.00 for HDL to provide Construction Administration Services during the Evergreen Avenue and Airport Road Pathway Project.

Administration's Recommendation:

To Approve Action Memorandum No. 23-0XX

April 28, 2023

Jude Bilafer
Director of Public Works
City of Palmer
231 West Evergreen Avenue
Palmer, AK 99645

Subject: Amendment #2 – Construction Phase Services
Evergreen Avenue and Airport Road Pathway

Dear Mr. Bilafer:

As requested, HDL Engineering Consultants, LLC (HDL) has prepared this amendment request to provide construction phase services for the Evergreen Avenue and Airport Road Pathway project.

Background and Summary

HDL began work in Fall 2022 with the field survey being completed in October 2022. The 65 percent design work began in November 2022 with the final bid-ready plans, specifications, and estimate completed and delivered on April 3, 2023. Bids for the project were opened on April 20, 2023 and the Notice of Intent to Award to Ahtna Construction Primary Products, LLC was sent out on April 25, 2023 with the award scheduled for the May 9, 2023 Palmer City Council meeting. Construction is anticipated to begin once roadway weight restrictions are lifted, which is generally in early to mid-June. The substantial completion is scheduled on or before August 1, 2023 with a final completion scheduled on or before September 1, 2023.

Amendment Request

Task 4 – Construction Phase Services

HDL will provide construction administration (CA) and part-time inspection services during construction. We will work closely with Palmer’s Public Works Department staff and will be the primary point of contact for all construction related communications. Our scope of work will include construction monitoring, coordination, administration, inspection, and record drawings.

- Civil Engineering
- Geotechnical Engineering
- Transportation Engineering
- Aviation Engineering
- W/WW Engineering
- Environmental Services
- Surveying & Mapping
- Construction Administration
- Material Testing

Construction Administration

At project start-up, HDL will review material and equipment submittals, shop drawings, samples, and Contractor work plans. HDL will conduct a pre-construction conference to review the Contractor's proposed schedule, establish procedures for submittals and shop drawings, and establish a working understanding between the Contractor, HDL, and Palmer.

During construction, HDL will review administrative submittals and schedules, and will review and respond to Design Clarification/Verification Requests (DCVRs). We will review Contractor pay requests and provide recommendations for payment. Due to the size of the project, we do not anticipate holding formal weekly construction meetings. However, we will meet with the Contractor as necessary during the work to ensure that all parties are engaged and aware of the project progress.

Construction Inspection

HDL will provide up to 140 hours of part-time inspection during the course of the work to observe and document the construction on behalf of Palmer. Construction documentation will include photographs and daily reports detailing the equipment, labor, inspections, testing, and activities occurring while our inspector is on site. Copies of daily reports will be provided to Palmer on a weekly basis. HDL will also conduct formal substantial and final completion inspections with Palmer.

Closeout Documents

HDL will review the Contractor's construction markups and prepare electronic record drawings. We will submit half-size record drawings on bond paper and in PDF format for your records. For construction contract closeout, we will request a release of liens and claims statement from the Contractor, and will distribute project completion and acceptance certificates for execution.

Assumptions

The following basic assumptions were used to prepare this estimate:

1. HDL will be the primary point of contact for verbal and written communication.
2. Our work excludes claims negotiations or protracted disputes with the Contractor, or if the Contractor's work extends beyond the performance period.
3. Our inspection hours are based on 24 hours a week (20 regular and 4 overtime hours) for five weeks and an additional 20 hours during substantial and final completion.
4. We anticipate maximizing efficiency by utilizing the airport project staff and vehicles.
5. HDL is not responsible for construction means, methods, techniques, sequences, or procedures, or for safety precautions and programs in connection with construction of the Project, or for acts or omissions of contractors, subcontractors, or any other persons performing construction of the project, or for the failure of any of them to carry out the Project in accordance with the Contract Documents.

Please let us know immediately if any of these assumptions are contrary to your anticipation so we may revise our proposed scope of work.

Cost Proposal

We propose to provide the aforementioned services on a time and expense basis at our published hourly rates for a cost not to exceed **\$32,510**. Further detail is included on the attached worksheet.

The level of effort required for CA services is highly dependent on the cooperation and skill of the contractor; the methods and equipment the contractor employs; the weather; the amount of rejected workmanship that must be retested; and the schedule he decides to work. None of these conditions is within HDL's control. We have prepared this estimate taking an optimistic view of potential difficulties based on our current understanding of the project and have not included claim negotiation, protracted disputes, or if the contractor's work extends beyond the construction period. Our CA services fee is a budget level estimate based on the above-discussed services and schedule. Anything contrary may result in additional cost to our work.

Sincerely,

HDL Engineering Consultants, LLC



Shawn Hull, PE

Mat-Su Transportation Manager

e: shull@HDLalaska.com | o: 907.746.5230

Attach: Cost Proposal (2 pages)

FIRM: HDL Engineering Consultants, LLC

PROJECT TITLE:
Evergreen Avenue-Airport Road Pathway

DATE: 4/28/2023

TOTAL NEGOTIATED FIXED FEE:

GROUP	TASK	LABOR (or FP)	INDIRECT COST	EXPENSES	TOTAL COST	FEE DISTRIBUTION	FIRM'S TOTAL PRICE	*SUB- CONTRACTS	PRICE PLUS SUBS
	1	\$0	\$0	\$0	\$0		\$0	\$0	\$0
	2	\$0	\$0	\$0	\$0		\$0	\$0	\$0
	3	\$0	\$0	\$0	\$0		\$0	\$0	\$0
	4	\$29,510	\$0	\$3,000	\$32,510		\$32,510	\$0	\$32,510
	5	\$0	\$0	\$0	\$0		\$0	\$0	\$0
	6	\$0	\$0	\$0	\$0		\$0	\$0	\$0
	7	\$0	\$0	\$0	\$0		\$0	\$0	\$0
	8	\$0	\$0	\$0	\$0		\$0	\$0	\$0
	9	\$0	\$0	\$0	\$0		\$0	\$0	\$0
	10	\$0	\$0	\$0	\$0		\$0	\$0	\$0
	11	\$0	\$0	\$0	\$0		\$0	\$0	\$0
	12	\$0	\$0	\$0	\$0		\$0	\$0	\$0

*Subcontractors for negotiated professional or technical services, products, etc. (Commodity items available to the general public at market prices, equipment use, and unit priced items are generally included in estimate as expenses.)

ESTIMATED TOTALS	LABOR (or FP)	INDIRECT COST	EXPENSES	TOTAL COST	FEE	FIRM'S TOTAL PRICE	*SUB- CONTRACTS	PRICE PLUS SUBS
FOR FIRM:	\$29,510	\$0	\$3,000	\$32,510	\$0	\$32,510	\$0	\$32,510

COST ESTIMATE PER TASK

FIRM: HDL Engineering Consultants			PROJECT TITLE: Evergreen Avenue-Airport Road Pathway										
TASK NO: 3		TASK DESCRIPTION: CA Services								DATE: 4/28/2023			
GROUP:		METHOD OF PAYMENT: FP <input type="checkbox"/> FPPE <input type="checkbox"/> T&E <input checked="" type="checkbox"/> CPFF <input type="checkbox"/>			PREPARED BY: Shawn Hull								
SUB-TASK NO.	SUB-TASK DESCRIPTION	LABOR HOURS PER JOB CLASSIFICATION											
		Project Manager	Construction Administrator	Inspector	Inspector (OT)	Clerical							
	Management & Coordination	6											
	Construction Start-up												
	Pre-Construction Meeting		4	2									
	Contractor Submittals		16										
	Project Administration												
	Construction Admin	8	50			2							
	Construction Inspection												
	Part-time Inspection (5 weeks)			100	20								
	Substantial/Final Inspection			20									
	Closeout												
	Record Drawings	1	4	8									
TOTAL LABOR HOURS		15	74	130	20	2	0	0	0	0	0	0	0
* LABOR RATES (\$/HR)		\$170.00	\$140.00	\$105.00	\$140.00	\$75.00							
LABOR COSTS (\$)		\$2,550.00	\$10,360.00	\$13,650.00	\$2,800.00	\$150.00							
EXPENSES						COMMENTS: Assumes - Part-time Inspection includes up to 24 hours per week (20 regular hours and 4 overtime hours) for five weeks plus 20 hours for substantial and final completion.							
SUB-TASK NO.	ITEM(S)	QTY	UNIT PRICE	TOTAL PRICE									
				\$0.00									
				\$0.00									
	Markup at 10%			\$0.00									
	Quality Assurance Testing (Allowance)	1	\$3,000.00	\$3,000.00									
			\$0.00	\$0.00									
			\$0.00	\$0.00									
TOTAL EXPENSES:						\$3,000	FIRM'S TOTAL COST OF LABOR (or Fixed Price):		\$29,510				
							IF CPFF, TOTAL INDIRECT COST @		0.00% \$0				
							FIRM'S TOTAL EXPENSES		\$3,000				
SUB-CONTRACTORS: Firm Initials and Price Per Task							FIRM'S TOTAL COST (no Subcontracts or Fee)		\$32,510				
FIRM:						Subtotal	10% Markup	TOTAL SUBCONTRACTOR PRICES:		\$0			
AMOUNT:						\$0	\$0	TOTAL COST + SUBCONTRACTOR PRICES:		\$32,510			

* Labor Rates shall be direct labor (base pay) only if Method of Payment is CPFF; otherwise, Labor Rates shall be total rates (i.e. base pay + benefits + overhead + profit.)